

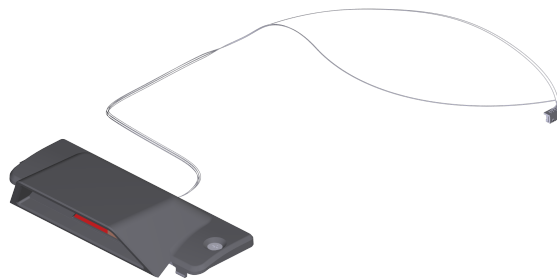

CX5/CX7 Side Scanner/Imager Kit Instructions



7772-K156
Issue C

Copyright

The product described in this document is a licensed product of NCR Voyix Corporation.

NCR CX7 All-in-One POS (7772) is a trademark of NCR Voyix Corporation in the United States and/or other countries. Other product names mentioned in this publication may be trademarks or registered trademarks of their respective companies and are hereby acknowledged.

Where creation of derivative works, modifications or copies of this NCR Voyix copyrighted documentation is permitted under the terms and conditions of an agreement you have with NCR Voyix, NCR Voyix's copyright notice must be included.

It is the policy of NCR Voyix Corporation to improve products as new technology, components, software, and firmware become available. NCR Voyix, therefore, reserves the right to change specifications without prior notice.

All features, functions, and operations described herein may not be marketed by NCR Voyix in all parts of the world. In some instances, photographs are of equipment prototypes. Therefore, before using this document, consult with your NCR Voyix representative or NCR Voyix office for information that is applicable and current.

Copyright © 2020–2024
By NCR Voyix Corporation
Atlanta, Georgia, USA
All Rights Reserved

Table of Contents

Copyright	2
CX5/CX7 Side Scanner/Imager	5
Kit Contents	5
Installation Procedure	6
Programming the Imager	11

Revision Record

Issue	Date	Remarks
A	Jun 2020	First Issue
B	Dec 2021	Added Warning statement
C	May 2024	Updated links from ncr.com to ncrvoyix.com

CX5/CX7 Side Scanner/Imager

This kit provides an Imager for Port B or Port C of NCR CX7 All-in-One POS (7772) or NCR CX5 All-in-One POS (7773).

Kit Contents

 Screw, M3x5, Steel, Flat Head, Phillips, Black Oxide
006-8626235

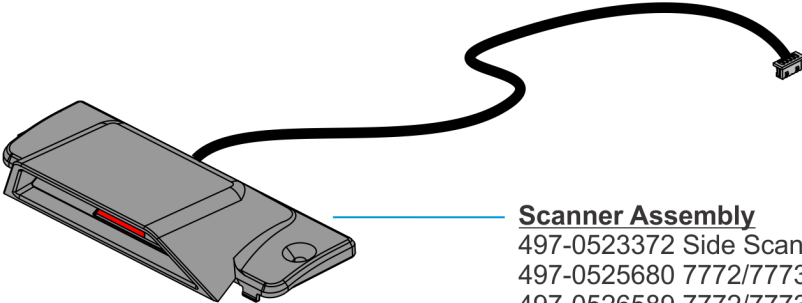

Scanner Assembly
497-0523372 Side Scanner Housing
497-0525680 7772/7773 Scanner Lens Assembly
497-0526589 7772/7773 Side Scanner Assembly
497-0526014 Cable, N6600 Imager
006-8617784 Screw, M2x5mm, Phillips, Pan Head

CCP-78261

Installation Procedure

Warning

Disconnect the AC power cord from the AC outlet and wait 30 seconds before servicing the terminal.

1. Lay the Display face down on a flat surface.
Always use a soft material (cloth, foam) to protect the display screen when placing the terminal face down.
2. Remove the Cable Cover.
 - a. Remove the two (2) screws that secure the Cable Cover to the Back Cover.

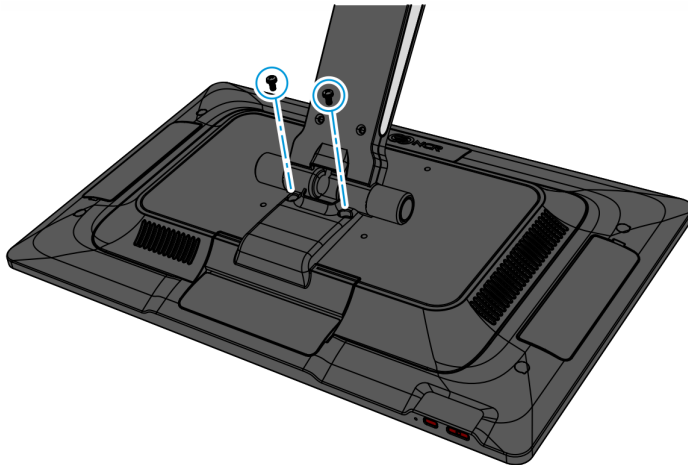

CCP-77013

- b. Rotate and unhook the Cable Cover from the Back Cover.

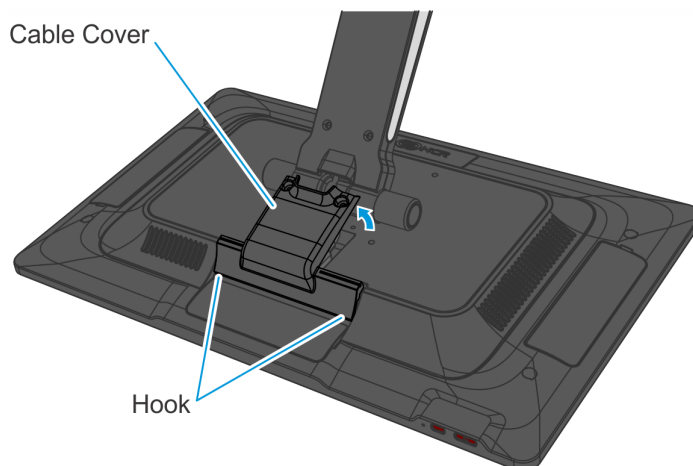

CCP-77014

3. Disconnect the Cables.

- a. Loosen the thumbscrew of the 180-degree USB-C Cable then disconnect the Cable.
- b. Remove the Ethernet Cable from the Cable Management Hook then disconnect the Cable.

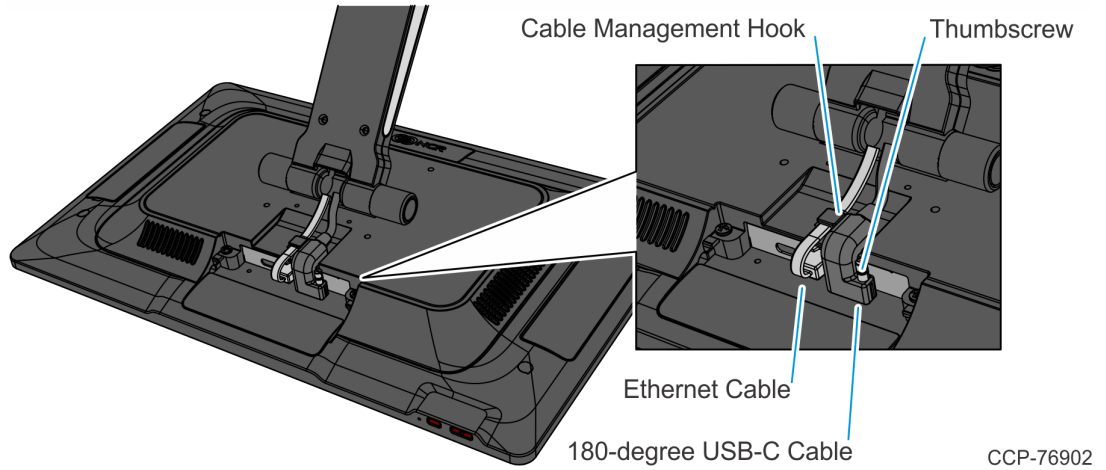

4. Loosen the two (2) captive screws that secure the Back Cover to the Display.

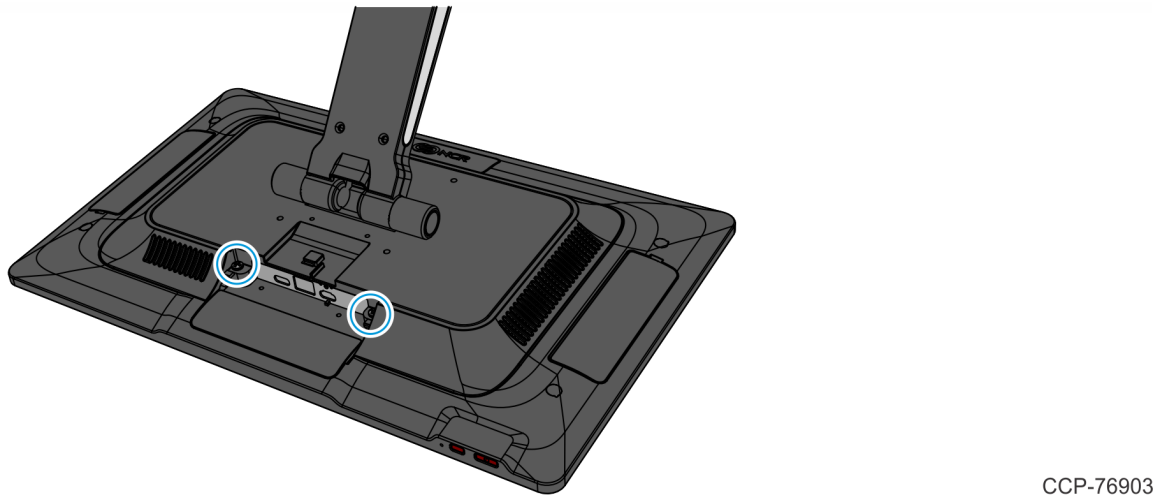

5. Rotate the Back Cover away from the Display and unhook the Back Cover Tabs.

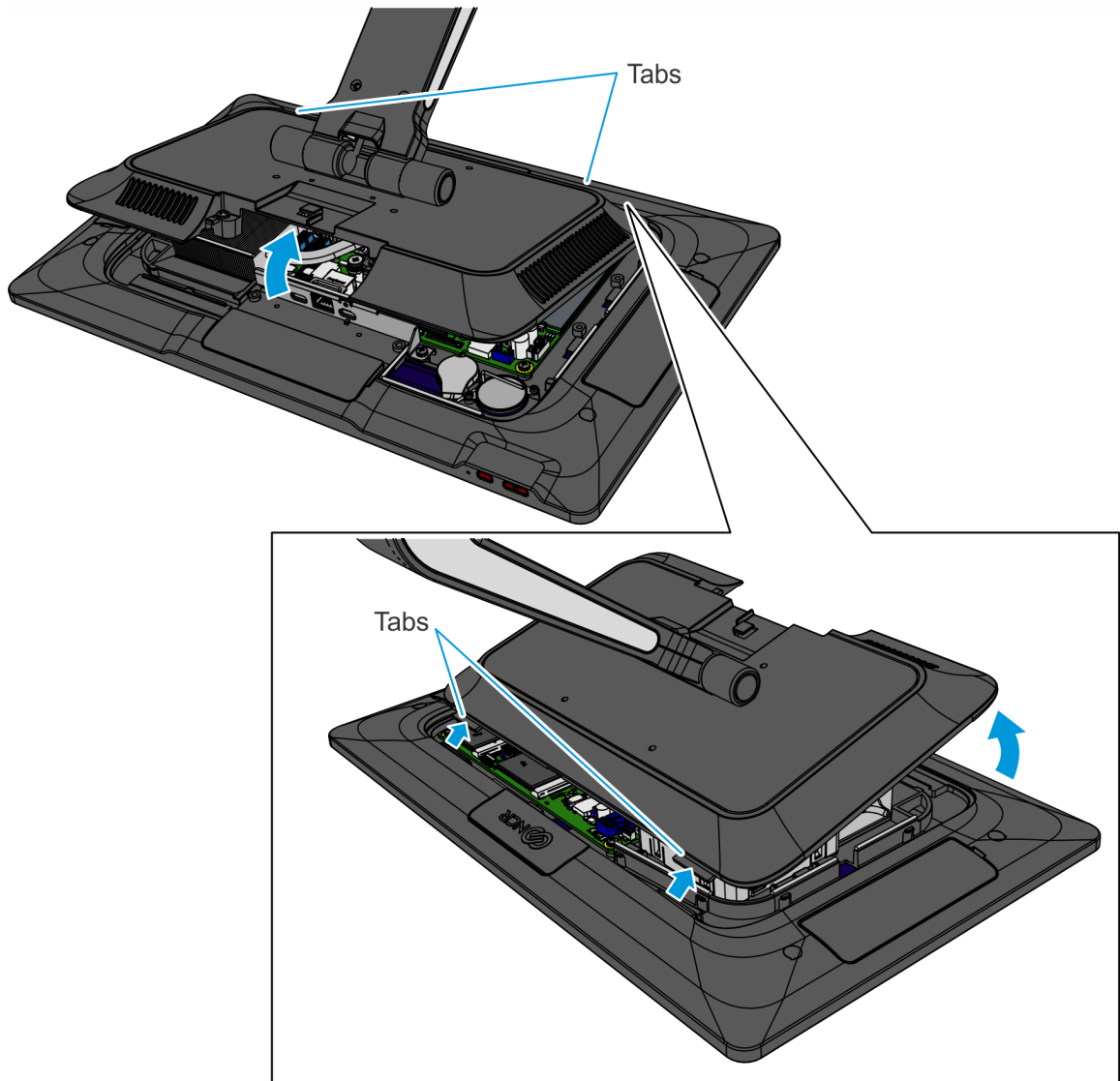

CCP-78836

6. The Imager can be installed on either Port B or Port C. Insert a flat screw driver in the slot of the desired port to unsnap the Plate from the display housing.

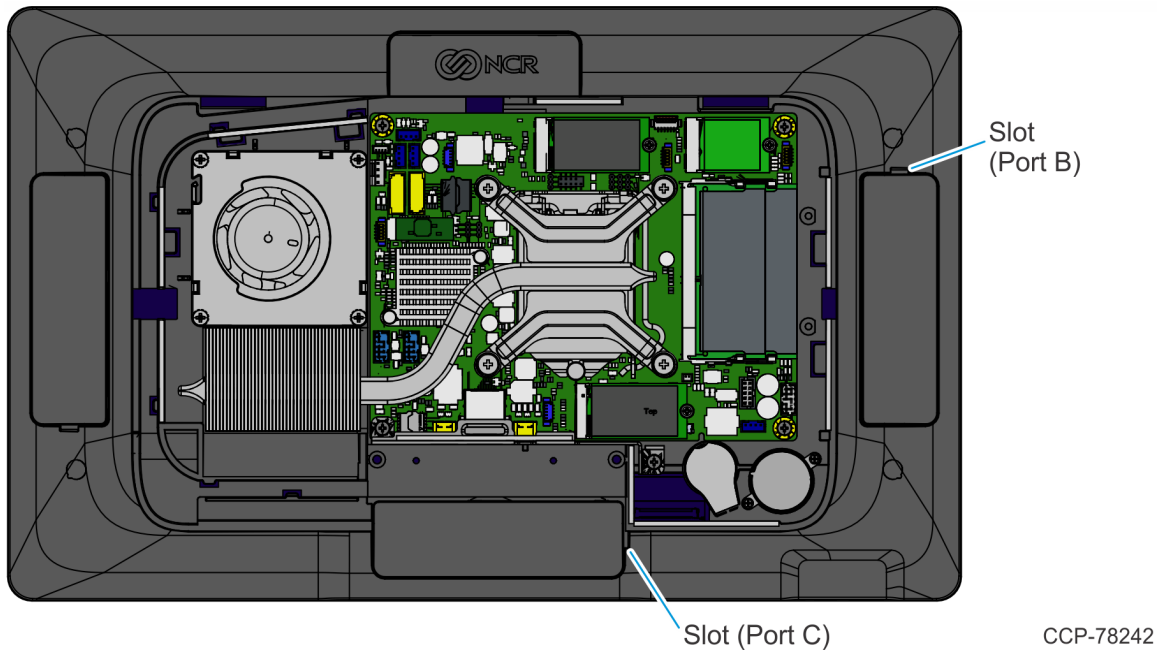

7. Route the Imager Cable through the Port opening.

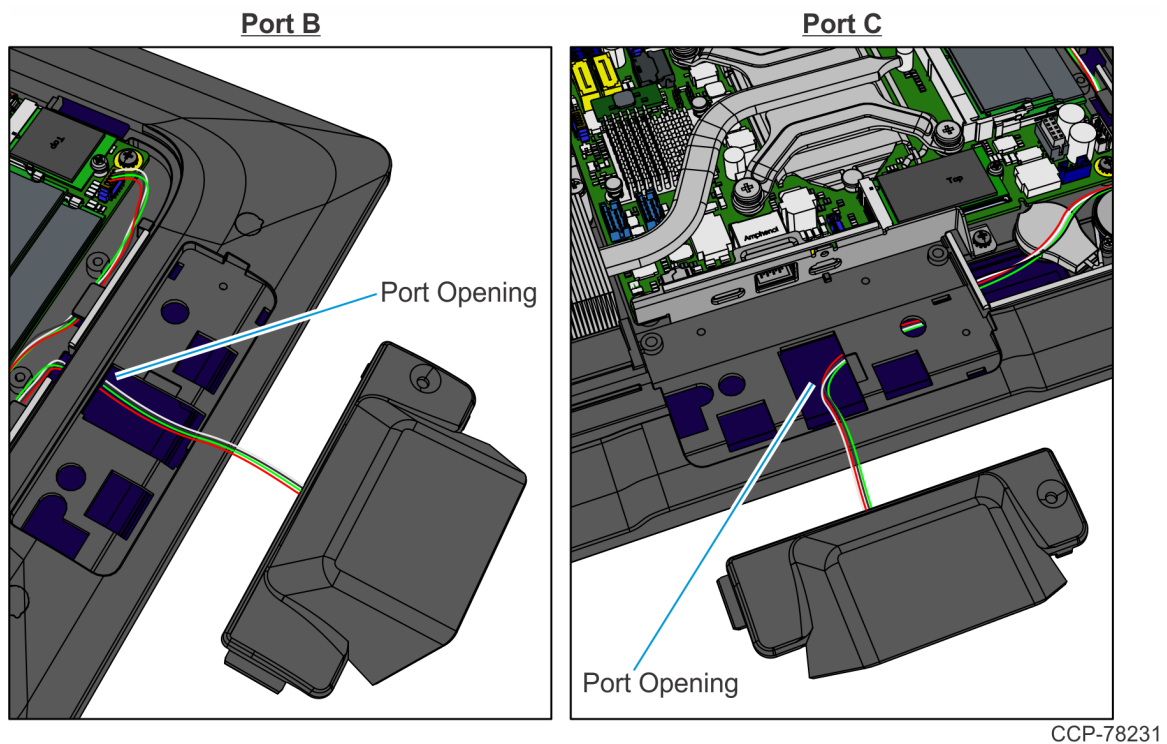

8. Route and secure the Cable under the Cable Management Hooks as shown, then connect the Cable to the Motherboard.

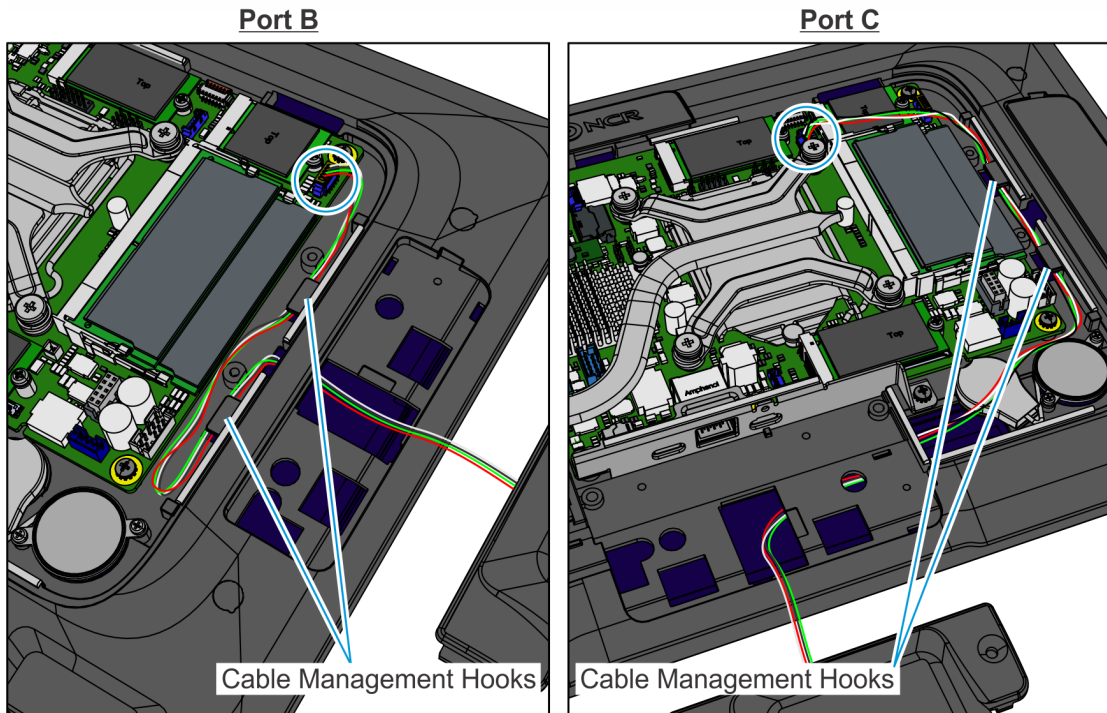

CCP-78230

9. Tuck the excess Cable under the display housing.

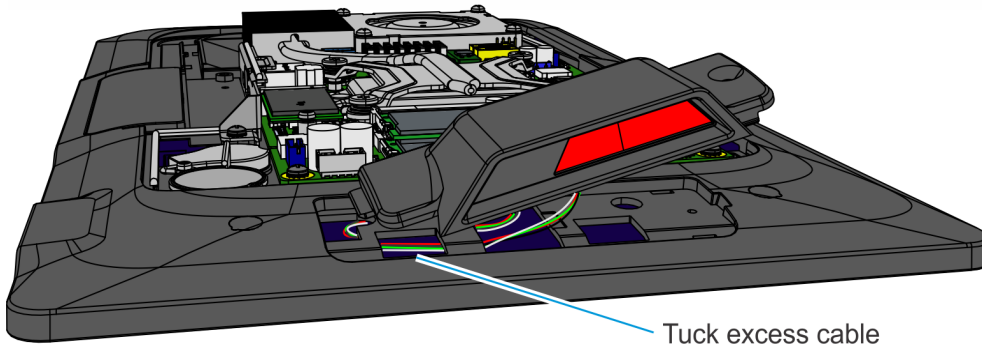

CCP-78234

10. Hook the Imager into the display housing and snap into place.

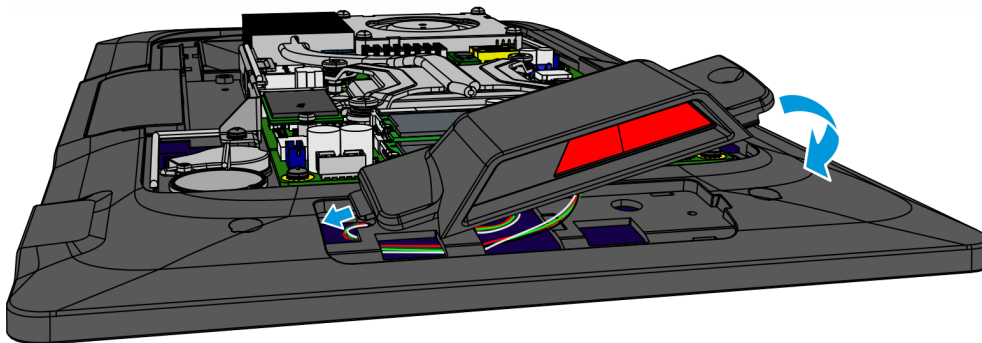

CCP-78233

Confidential and proprietary information of NCR Voyix.
Use and disclose solely pursuant to company instructions.

11. Secure the Imager with a screw.

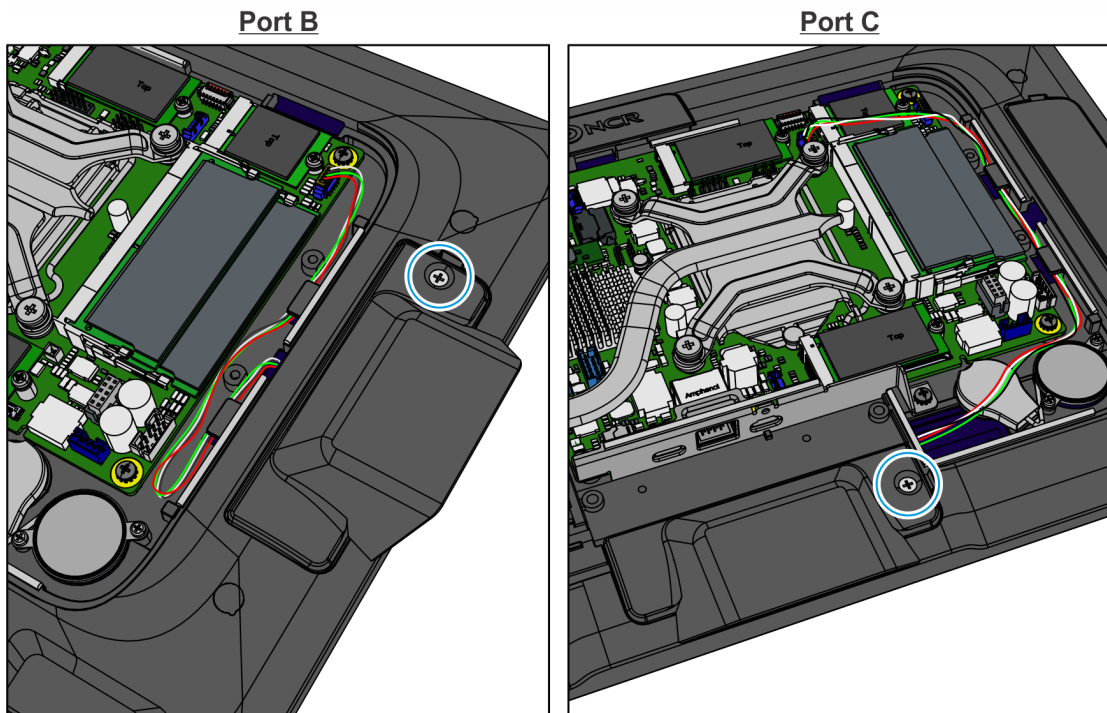

CCP-78227

12. Reinstall the Display Back Cover.

13. Reconnect the 180-degree USB-C Cable and Ethernet Cable.

14. Reinstall the Cable Cover.

Programming the Imager

To program the imager to work on a Retail or Hospitality (Aloha) POS, refer to the following sections in the Imager Setup Sheets document (BCC5-0000-5470):

<https://onlinehelp.ncrvoyix.com/Retail/Scanners/ImagerSetup/HTML/FrontMatter-HTML/Home.htm>

- **Retail**
 - Honeywell N6600/N6700 Retail Quick Imager Setup
- **Hospitality (Aloha)**
 - Honeywell N6600 Aloha Programming Sheet

Confidential and proprietary information of NCR Voyix.
Use and disclose solely pursuant to company instructions.