

KIT INSTRUCTIONS

500GB Hard Disk Drive

7702-K260
Issue B



The product described in this book is a licensed product of NCR Corporation.

NCR is a registered trademark of NCR Corporation. NCR RealPOS is a trademark of NCR Corporation in the United States and/or other countries. Other product names mentioned in this publication may be trademarks or registered trademarks of their respective companies and are hereby acknowledged.

The terms HDMI and HDMI High-Definition Multimedia Interface, and the HDMI Logo are trademarks or registered trademarks of HDMI Licensing LLC in the United States and other countries.

Where creation of derivative works, modifications or copies of this NCR copyrighted documentation is permitted under the terms and conditions of an agreement you have with NCR, NCR's copyright notice must be included.

It is the policy of NCR Corporation (NCR) to improve products as new technology, components, software, and firmware become available. NCR, therefore, reserves the right to change specifications without prior notice.

All features, functions, and operations described herein may not be marketed by NCR in all parts of the world. In some instances, photographs are of equipment prototypes. Therefore, before using this document, consult with your NCR representative or NCR office for information that is applicable and current.

To maintain the quality of our publications, we need your comments on the accuracy, clarity, organization, and value of this book. Please use the link below to send your comments.

Email: FD230036@ncr.com

Copyright © 2014-2017
By NCR Corporation
Duluth, GA U.S.A.
All Rights Reserved

Revision Record

Issue	Date	Remarks
A	Aug 2014	First Issue
B	May 2017	Updated P/N 006-8624543 to 006-8626300

500GB Hard Disk Drive

This kit contains the components to add a second Hard Disk Drive to the RealPOS XR7 POS.

Components

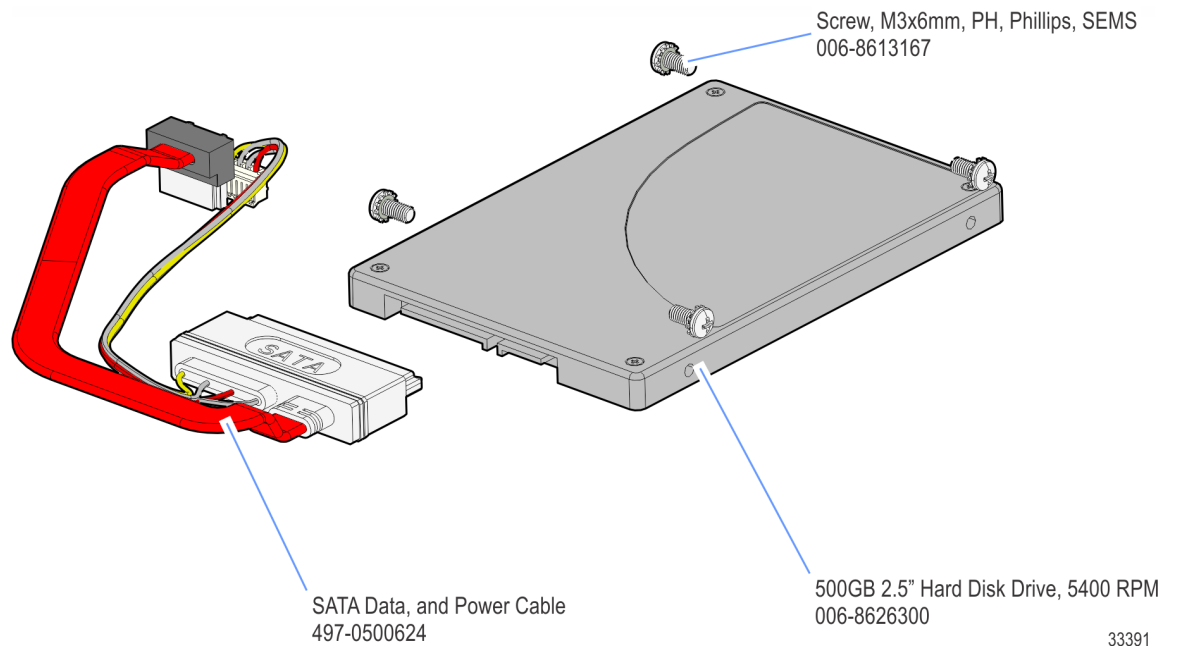

Installation Procedures

1. Remove the Base Stand.
 - a. Lay the terminal face down on a flat surface.



Caution: Always use a soft material (cloth, foam) to protect the display screen when placing the terminal face down.

- b. Remove the screws (2) that secure the Base Stand to the display.

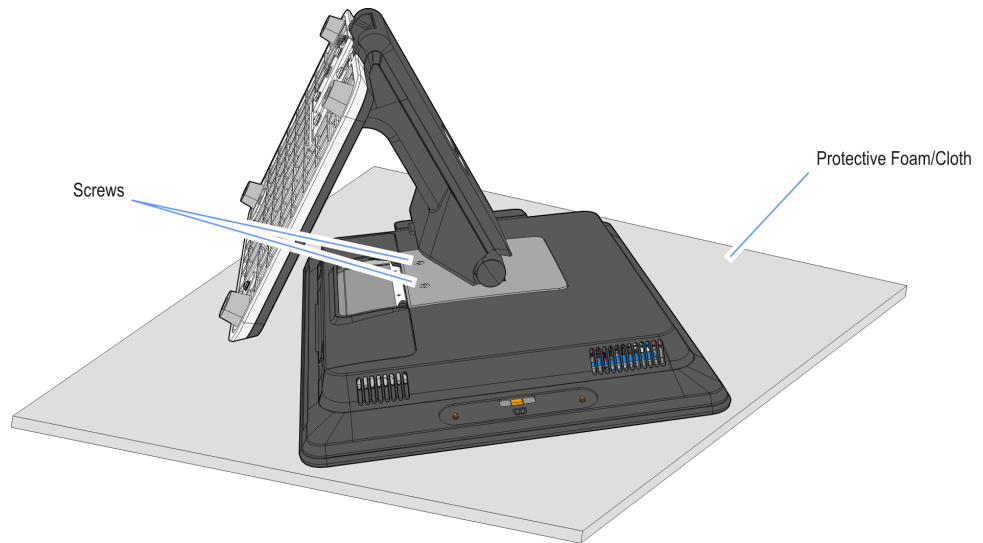

32809

- c. Rotate the Table Top Stand and remove the Mounting Plate Studs (2) from the openings in the Rear Cover.

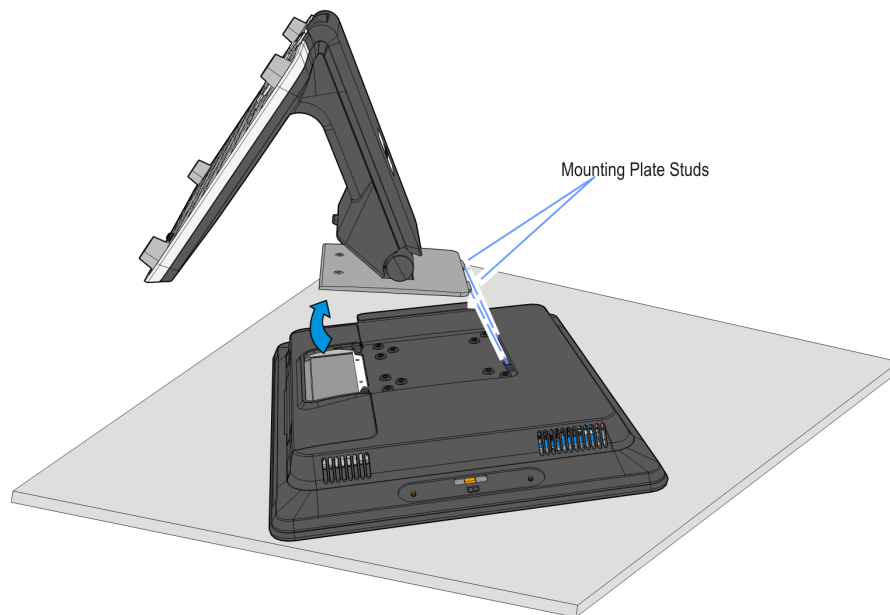

32808a

2. Remove the Rear Cover.
 - a. Loosen the captive screws (2) that secure it to the chassis.
 - b. Pivot the Rear Cover as shown to remove it.

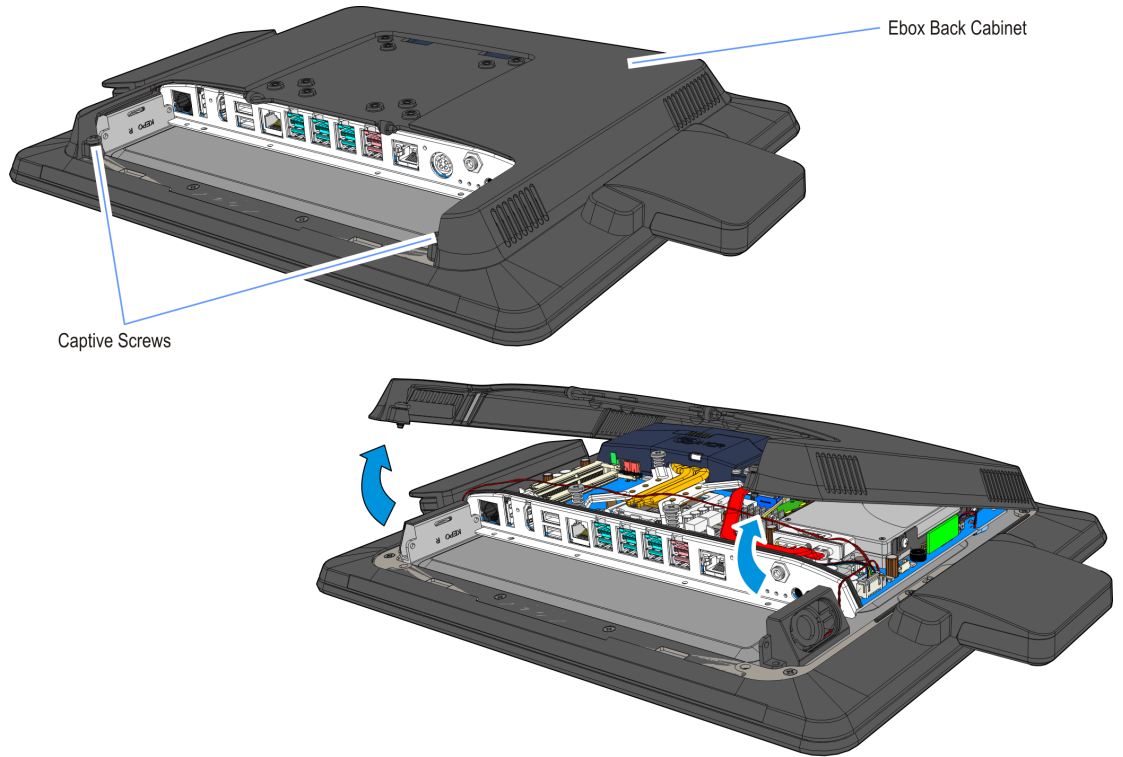

328221

3. Remove the screws that secure the HDD Bracket to the Motherboard.

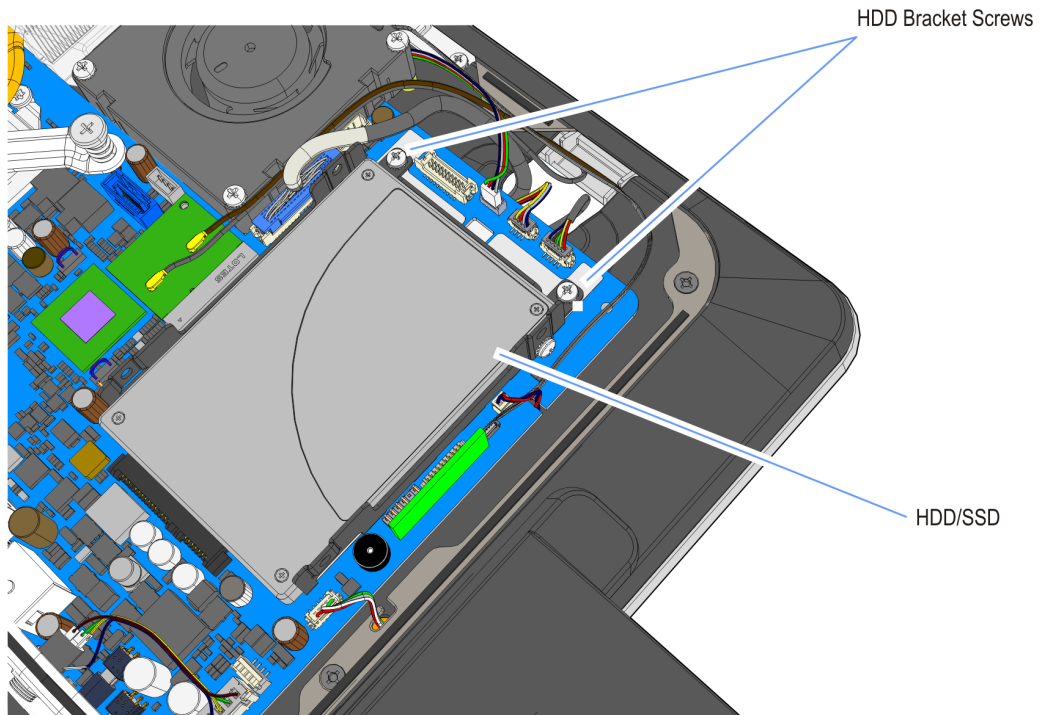

32827

- Slide the HDD Assembly slightly to the top to disengage the HDD from the Motherboard connector.

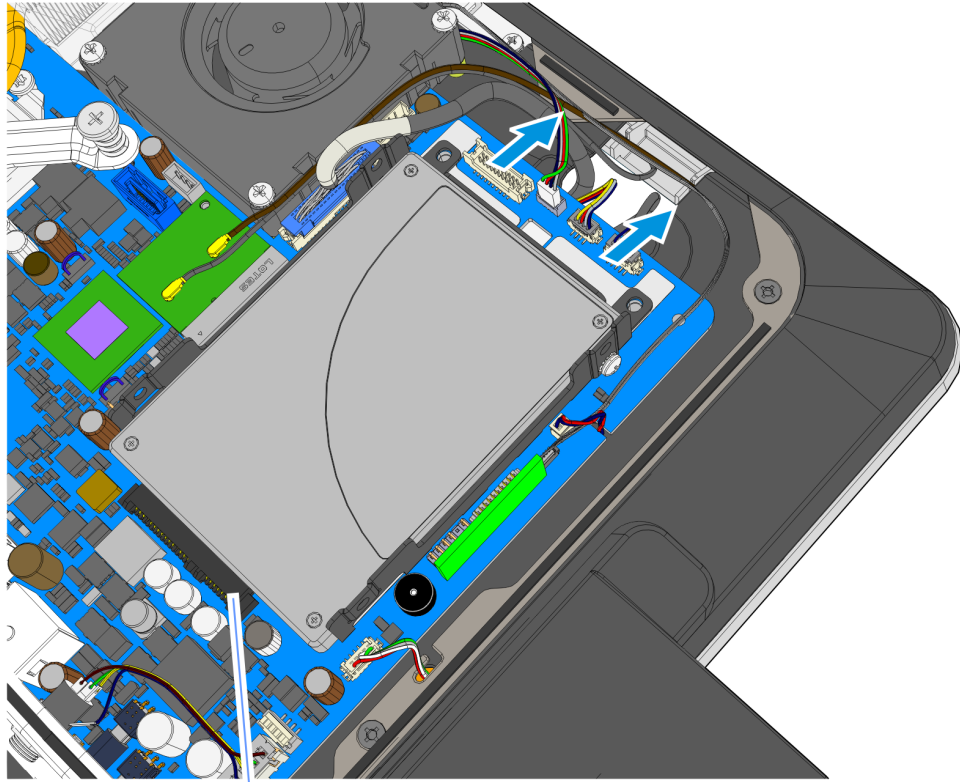

HDD SATA/Power Connector

32826

- Install the second HDD onto the HDD Bracket (4 screws).



Note: It may be necessary to temporarily loosen the screws in the lower HDD to allow the bracket to relax and make room for the top HDD.

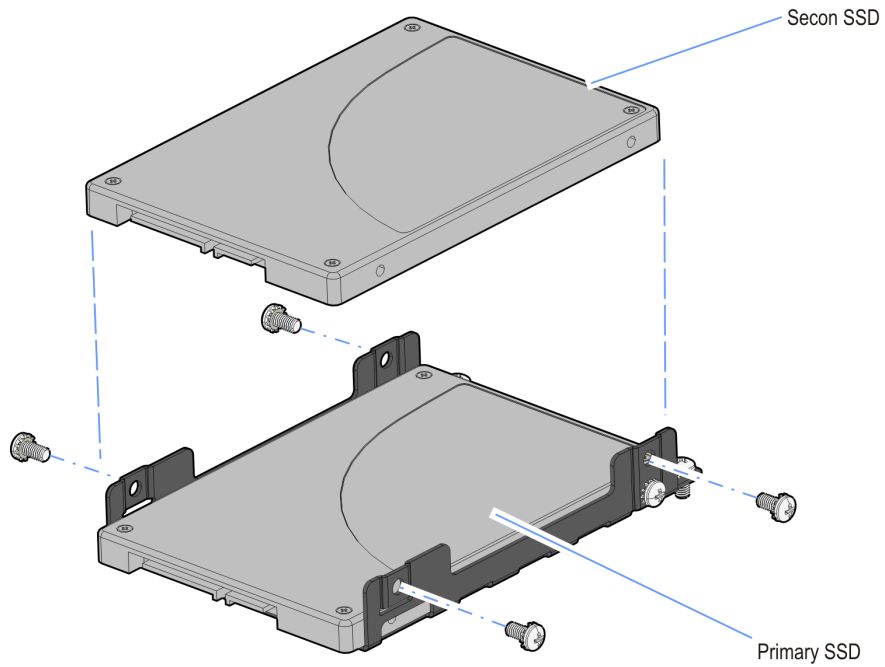

33388

- 6. Connect the Secondary HDD SATA/Power Cable to the Secondary SSD.

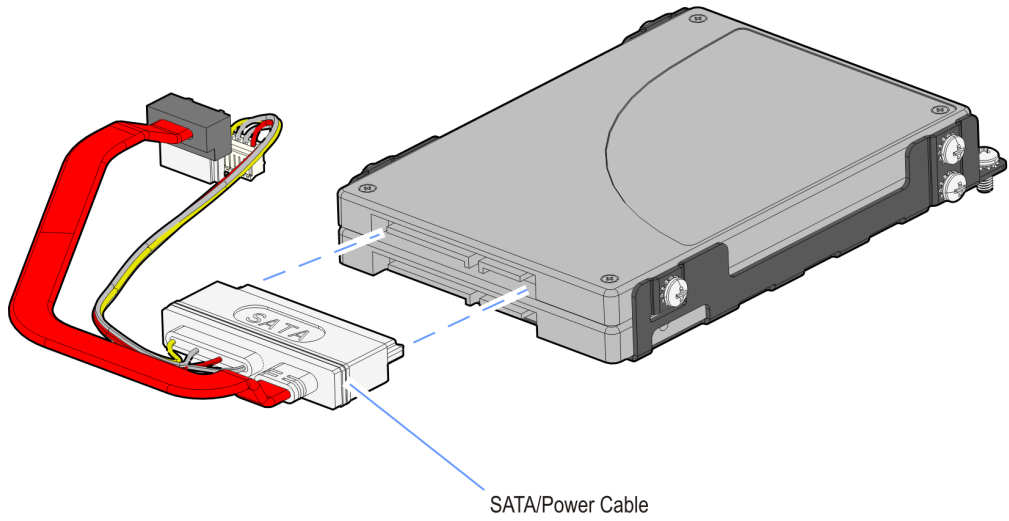

33389

- 7. Install the HDD Assembly in the terminal.
 - a. Connect the Primary HDD to the Motherboard connector.

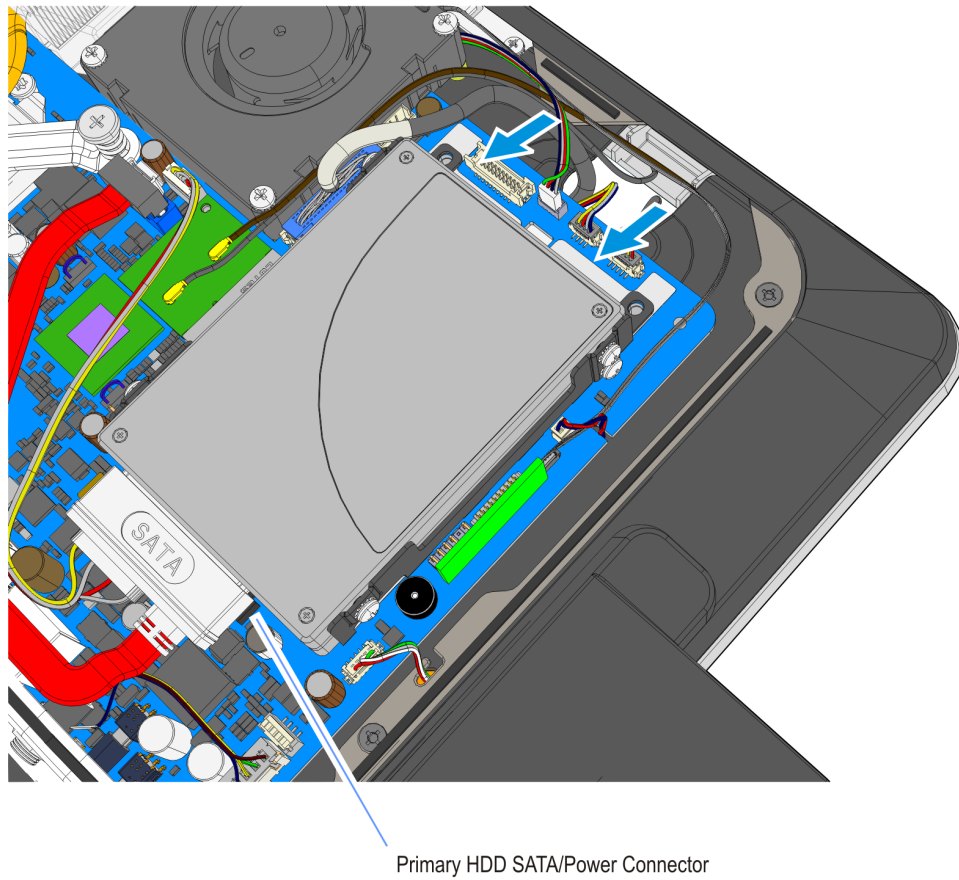

32825a

b. Secure the HDD Bracket to the Motherboard (2 screws).



8. Connect the Secondary HDD SATA and Power Cables to the Motherboard.

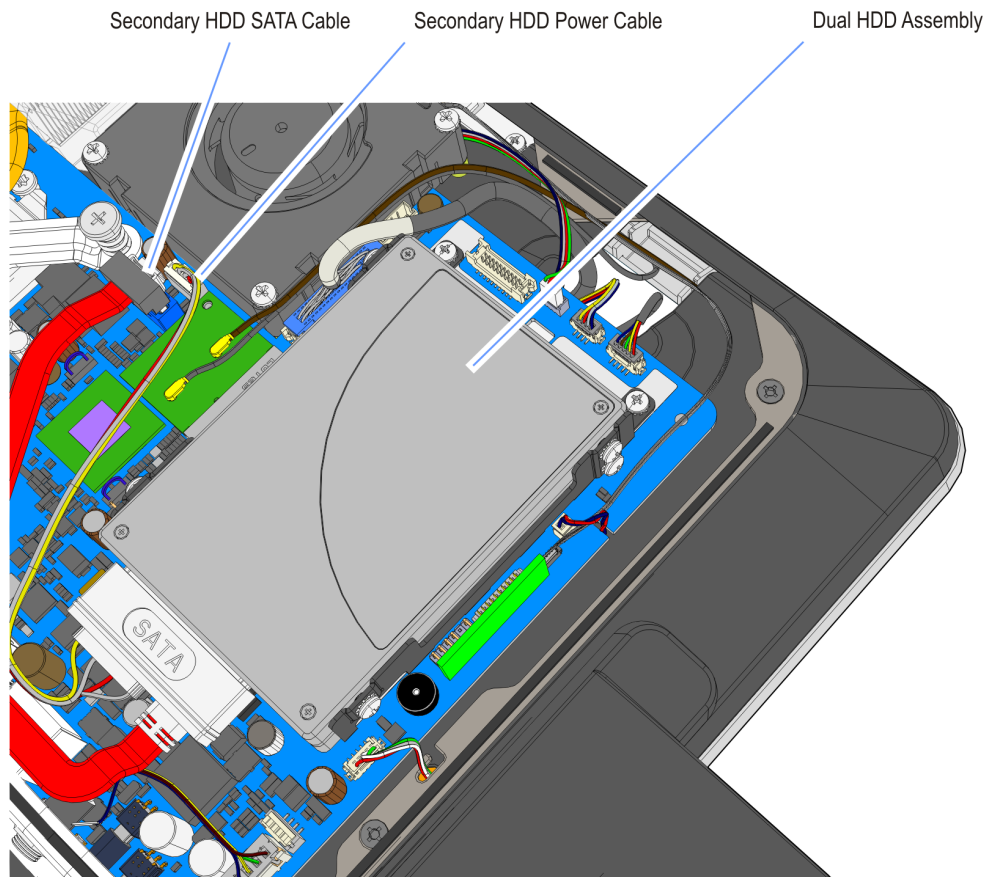

32823

9. Reinstall the Rear Cover.
10. Reinstall the Base Stand.

