

7403-K452

Rear Consumer Display Pole Mount

Kit Instructions



Issue B

Revision Record

Issue	Date	Remarks
A	Nov 2008	First issue
B	June 2009	Removed Interface Cable from the kit contents

Introduction

This kit provides an adapter (Customer Display Base) and screws (spares) that are used for integrating the NCR 5975 VFD Customer Display on the back of a an NCR 7403 terminal.

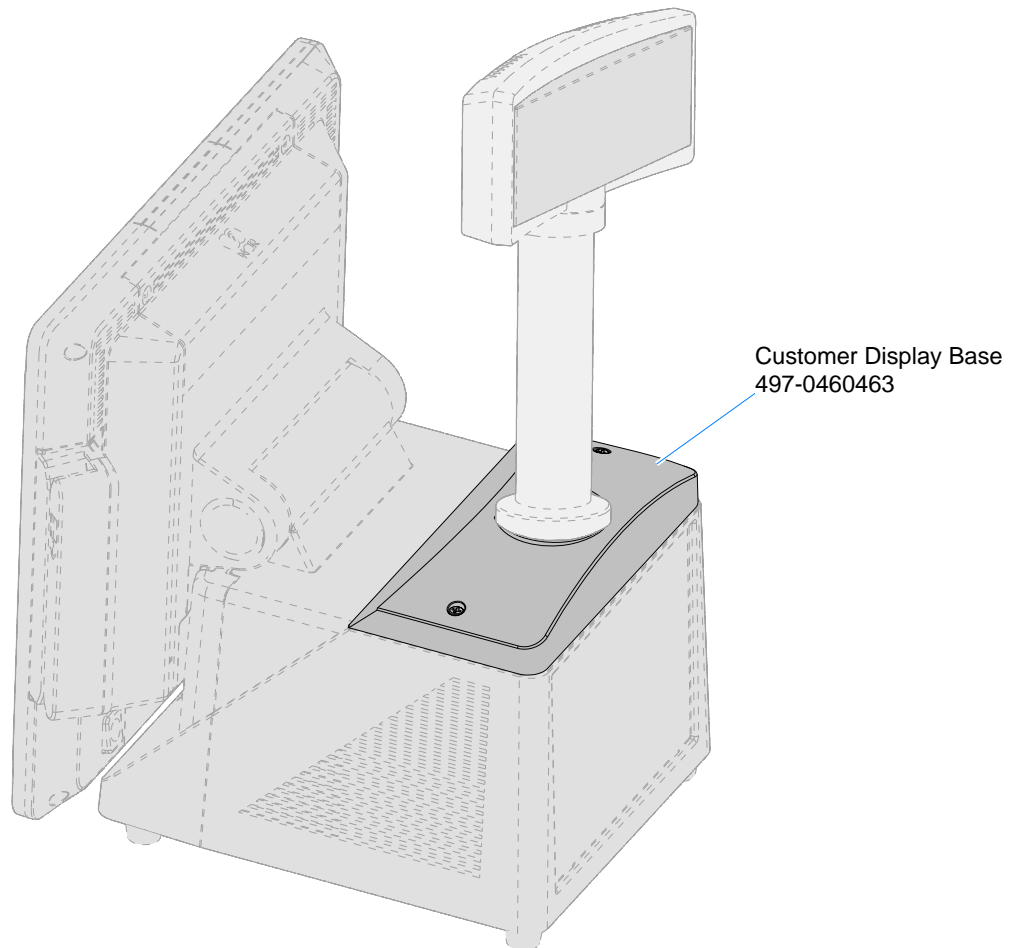

26344c

Note: The required interface cable for the NCR 5975 Display is ordered separately.

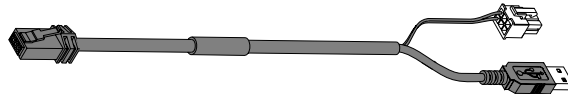

Powered USB 12V Cable
497-0465142
(1432-C340-0006)

26344b

There are two models of the NCR 5975 Customer Display: They are installed using the same procedure.

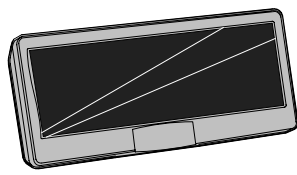

5975-1xxx 2x20 VFD

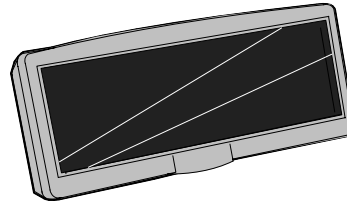

5975-2xxx Graphical Display

26332

There are four different length posts available, in four inch increments.

- 5975-K834: 102 mm (4 in.) and 203 mm (8 in.) poles
- 5975-K836: 305 mm (12 in.) and 406 mm (16 in.) poles

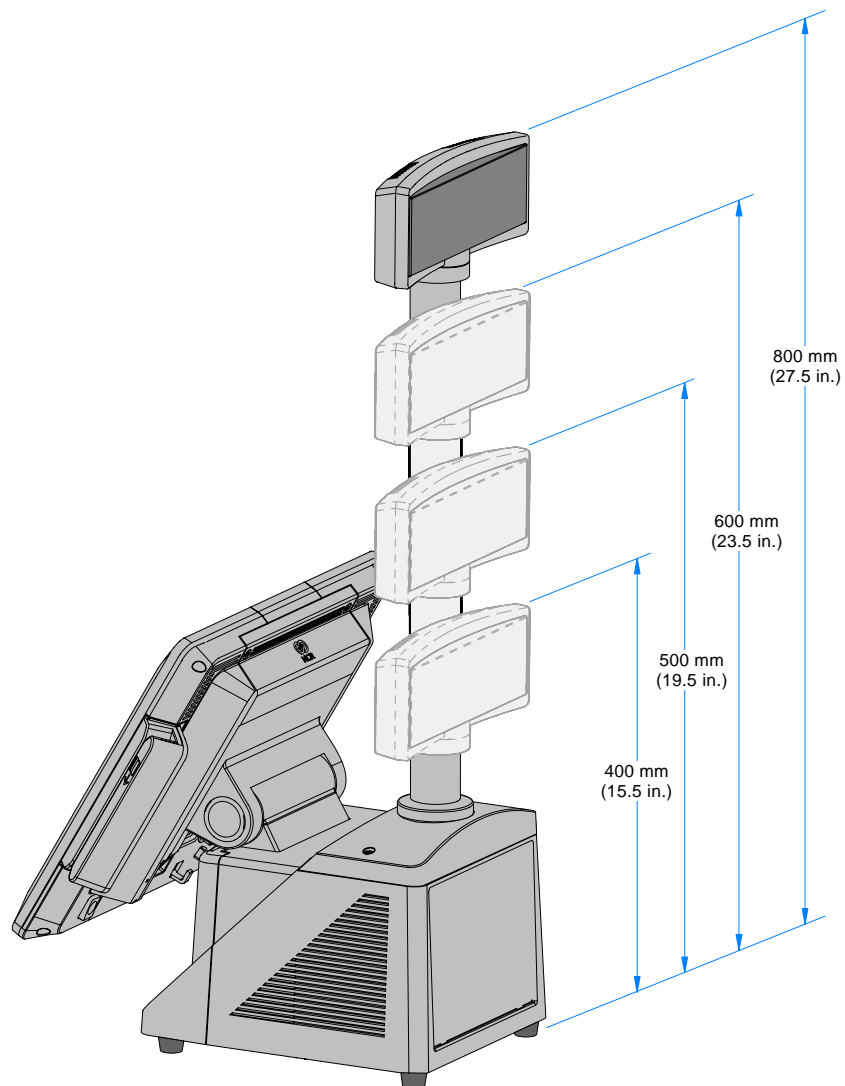

26336

Installation Procedures

Caution: Static Electricity Discharge may permanently damage your system. Discharge any static electricity build up in your body by touching your computer's case for a few seconds. Avoid any contact with internal parts and handle cards only by their external edges.

1. Disconnect power to the terminal.

Caution: Disconnect the AC power cord before disassembling the terminal. The ON/OFF switch does **NOT** remove power to the unit.

- a. Remove the Front Cover.
- b. Insert the Security Key and turn it 90 degrees clockwise.

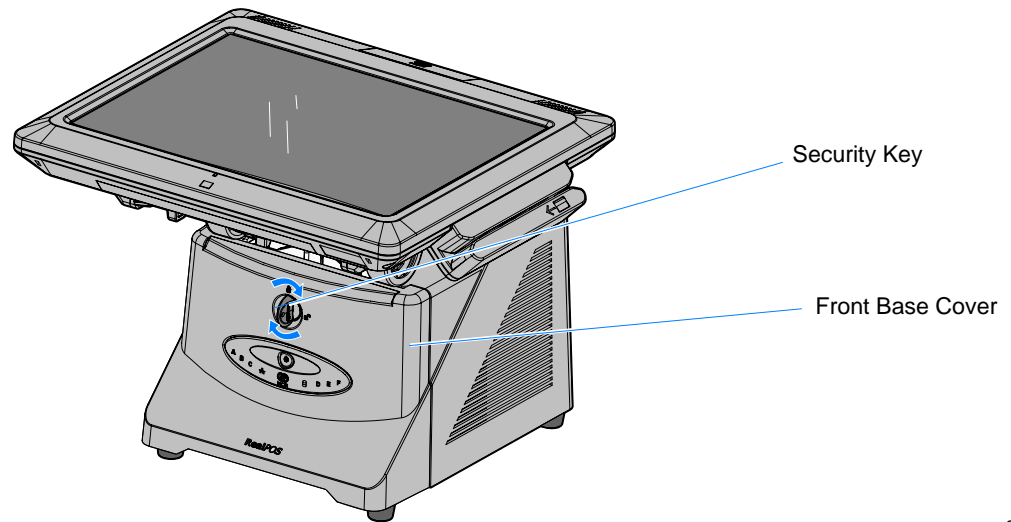

- c. Pivot the top of the Front Base Cover toward the front of the unit and remove it from the terminal.

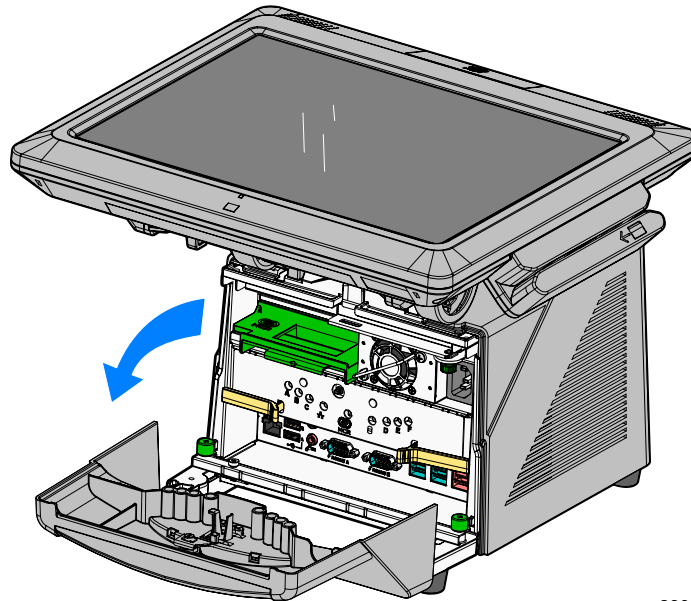

26032a

- d. Disconnect the Power Cord from the Power Supply.

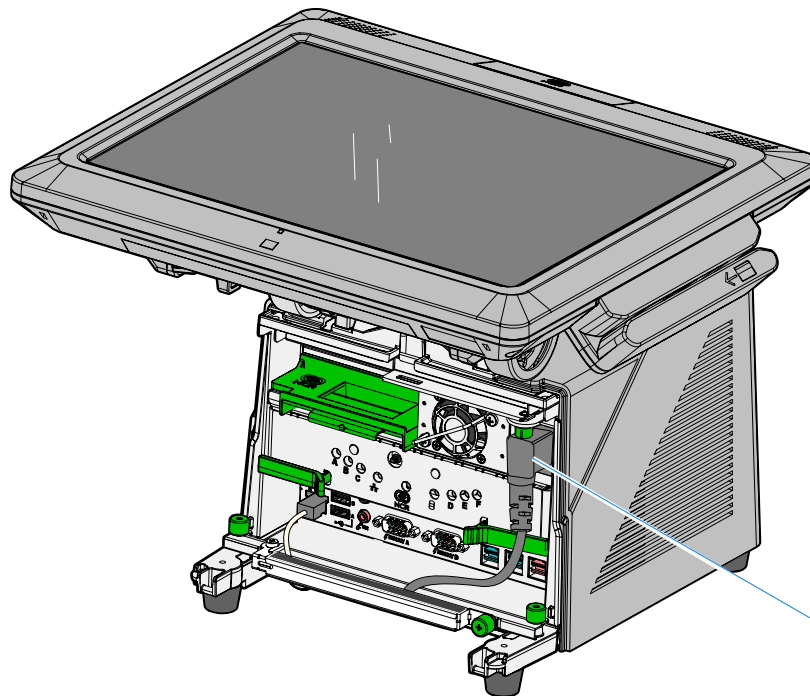

AC Power Cord

26135b

2. If present, remove the Signage Insert (and Signage) from the back of the 7403. The insert has two extensions on the top and bottom that are inserted in matching slots on the cabinet. It is very flexible so you can remove it off using your fingernail or a sharp object.

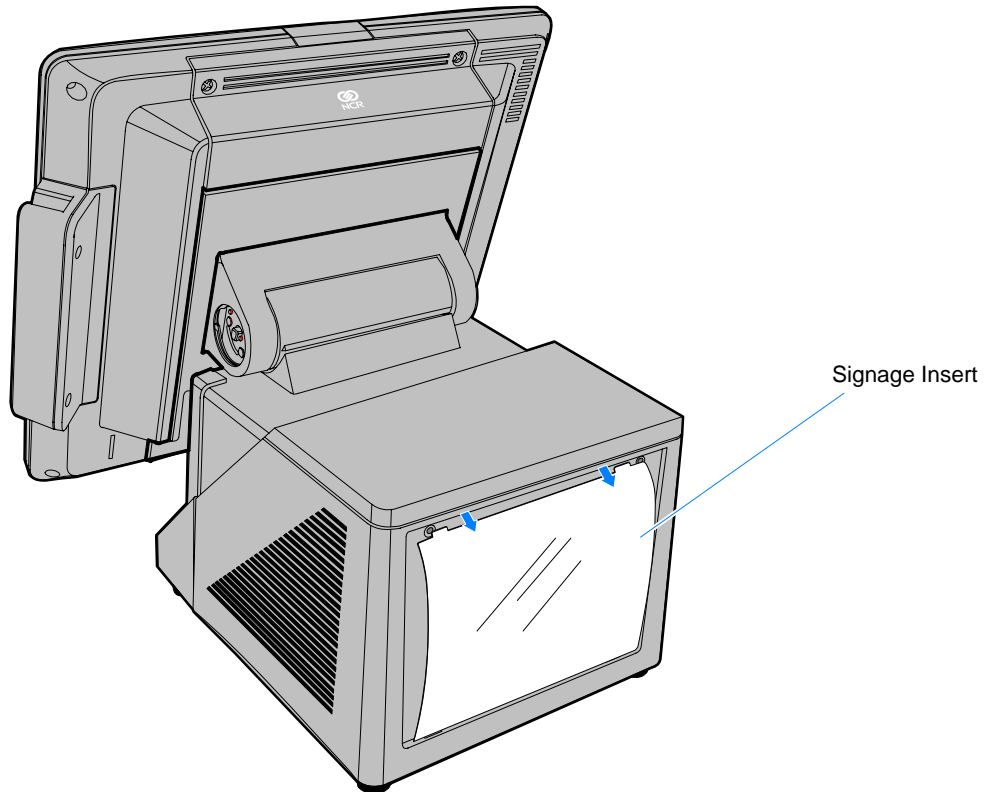

26252b

3. Remove the No Customer Display (2 Screws).

Note: Do not discard these screws. They are use later to secure the Customer Display Assembly. There are two spare screws provided in the kit if these get misplaced.

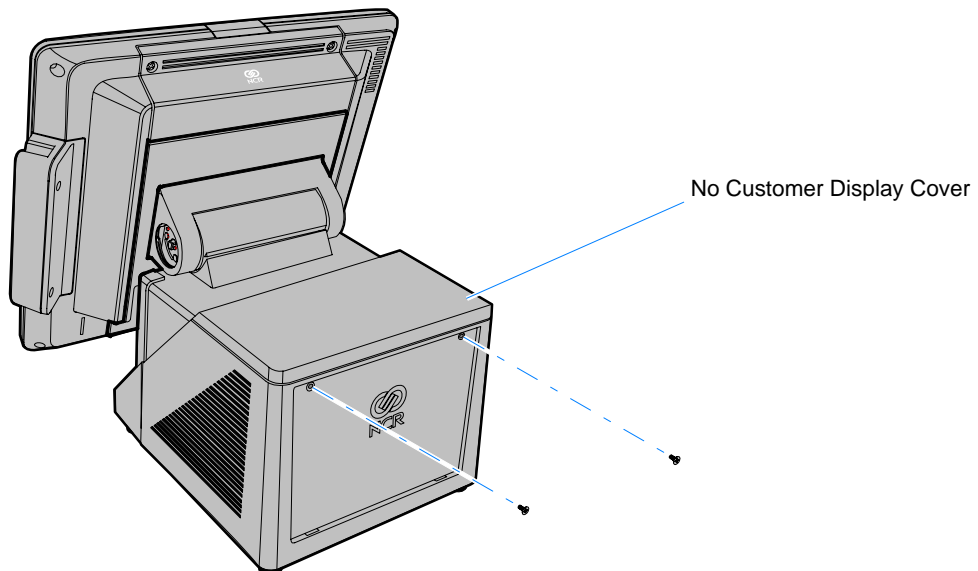

26045a

4. Connect the Interface Cable to the Display Module.
 - a. Remove the screws (2) from the Display Back.
 - b. Remove the Display Back.
 - c. Route the Interface Cable through the opening in the Display Back.
 - d. Connect the Display Cable to the USB connector on the Display Module.

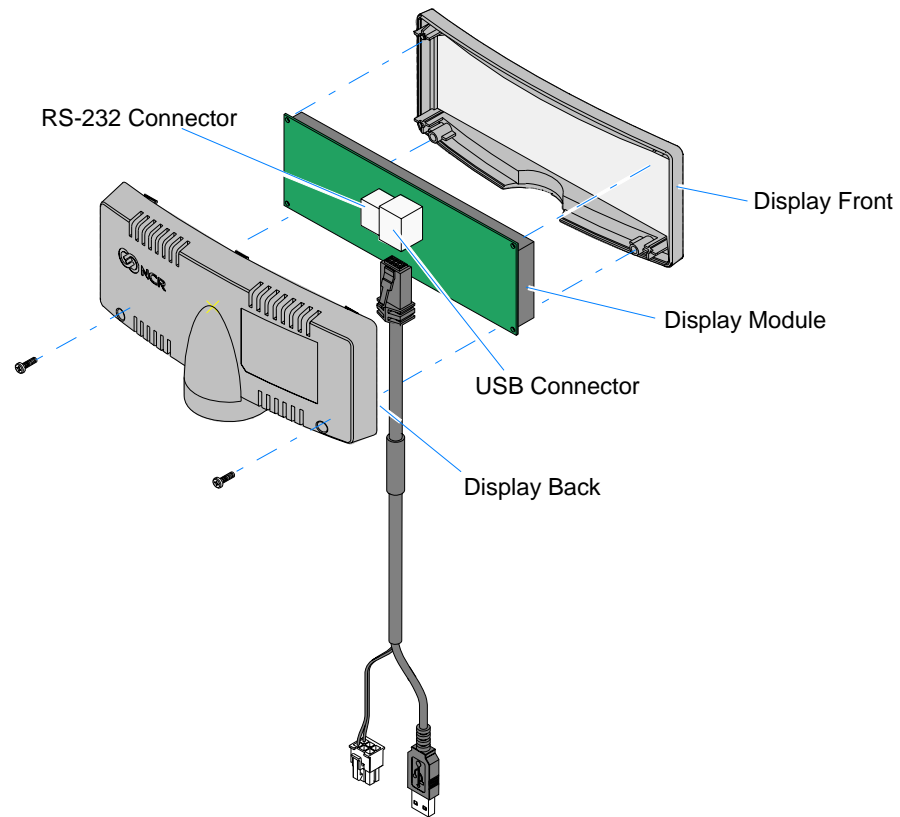

- e. Reassemble the Display Assembly.

5. Route the Interface Cable through the Post and assemble the components.

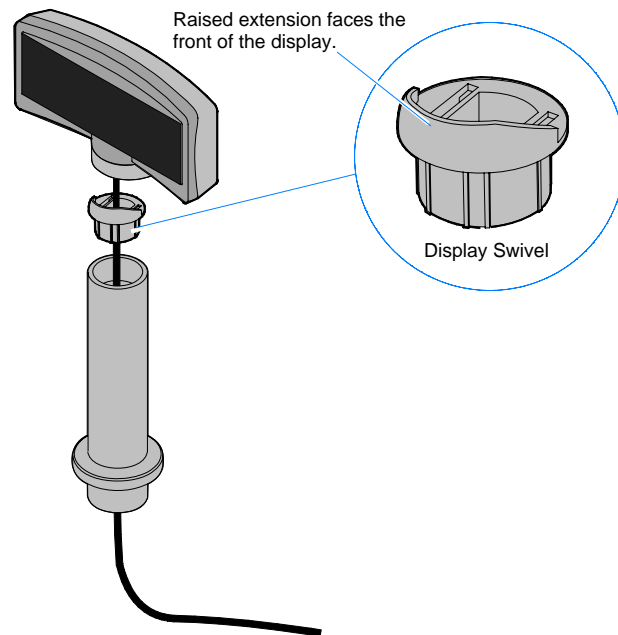

26337

6. Route the cable through the opening in the Customer Display Base.
7. Insert the Customer Display Assembly in the Customer Display Base. This is a simple friction fit.

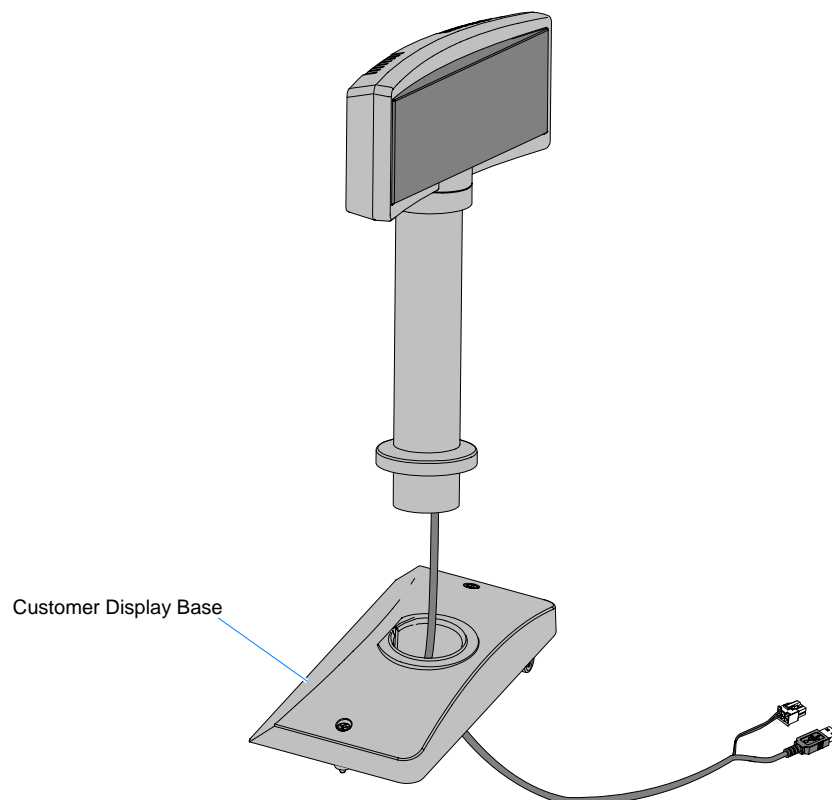

26468

8. Connect the Display Cable to the Backplane Board.

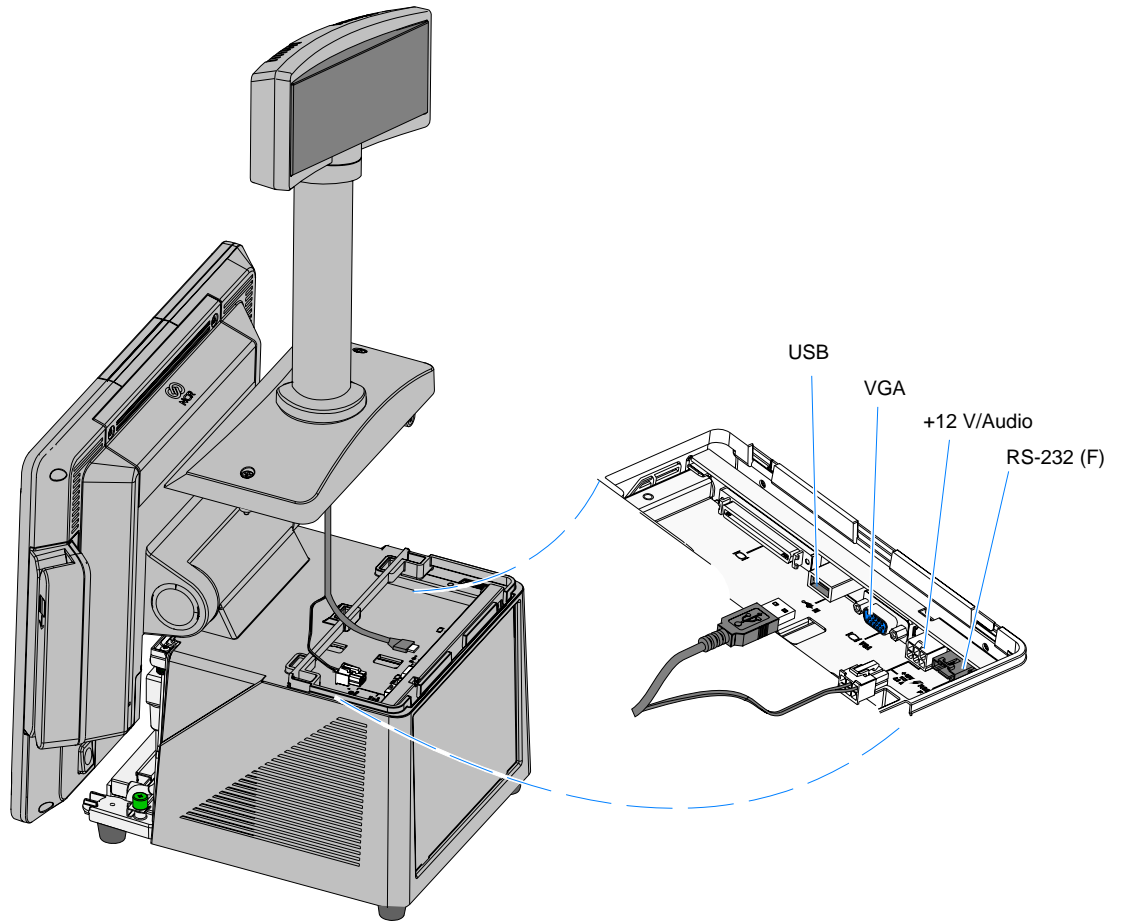

9. Install the Customer Display Assembly on the Base of the 7403. Secure it with the Base Rear Cover Screws (2) and the Spring-Loaded Captive Screws (2) in the Customer Display Mounting Base.

Note: Coil the excess Display Cable under the Display Mount.

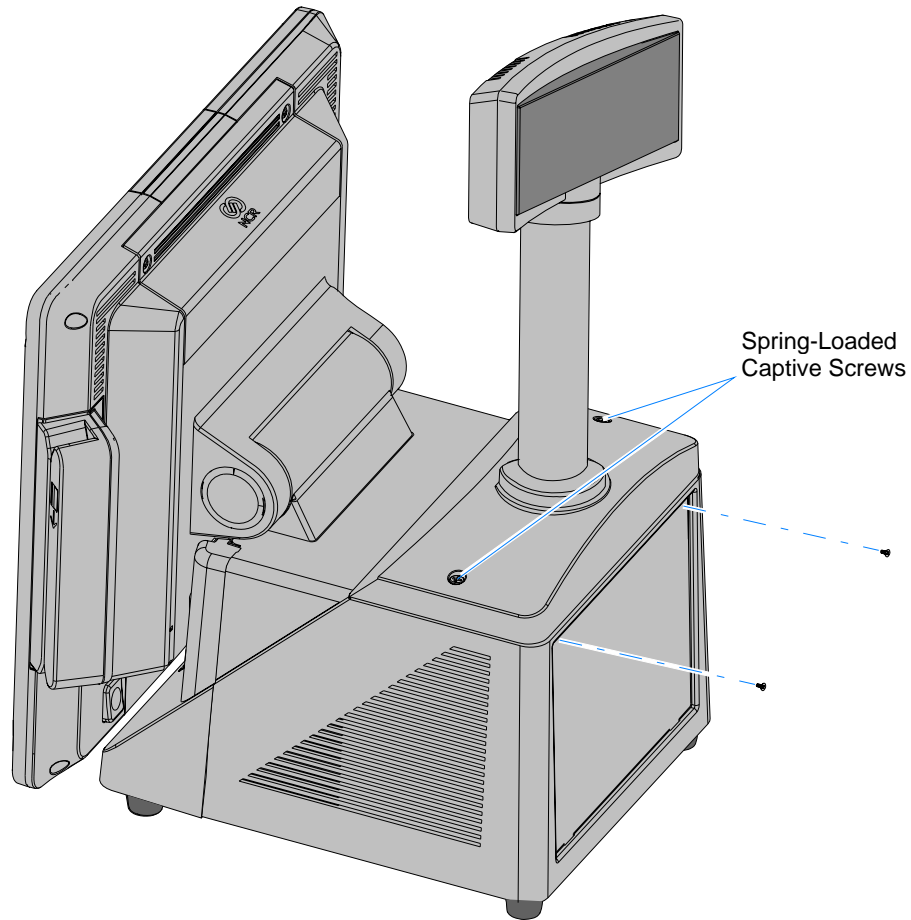

26470a

10. Reconnect the AC Power Cord and replace the Base Front Cover.
11. Re-install the Information Sheet and Signage Insert in the Base Rear Cover (if applicable).