

7409-K227/K229

MSR

Kit Instructions



Issue A

Revision Record

Issue	Date	Remarks
A	Feb 2013	First issue

Introduction

This kit provides an MSR module that mounts on the side of the 7409 Display Head. There are two versions:

- JIS MSR (7409-K227)
- ISO MSR (7409-K229)

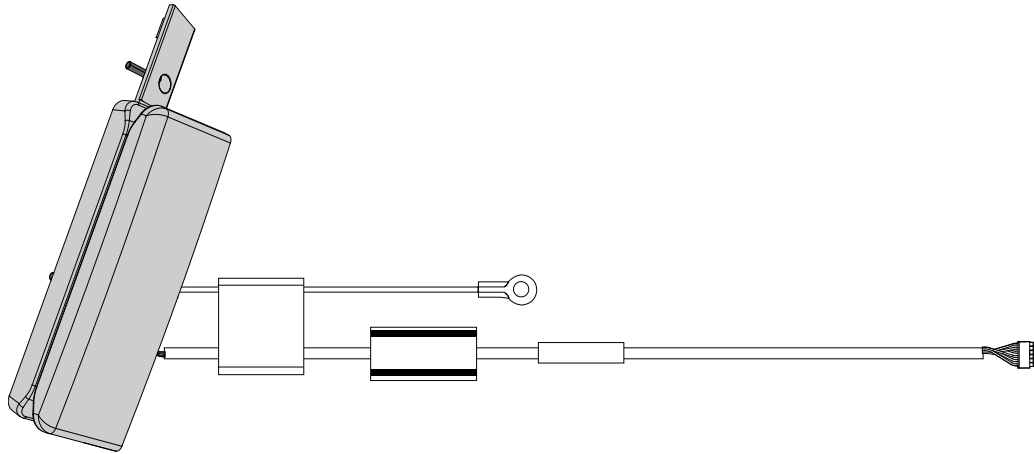

Installation Procedures

Warning: Disconnect the AC power cord before disassembling the Terminal.

1. Remove the Display Head from its mount.

Removing the 7409 from the Table Top Mount

- a. Release the Mounting Plate Latches and tilt the display back. Relock the latches.

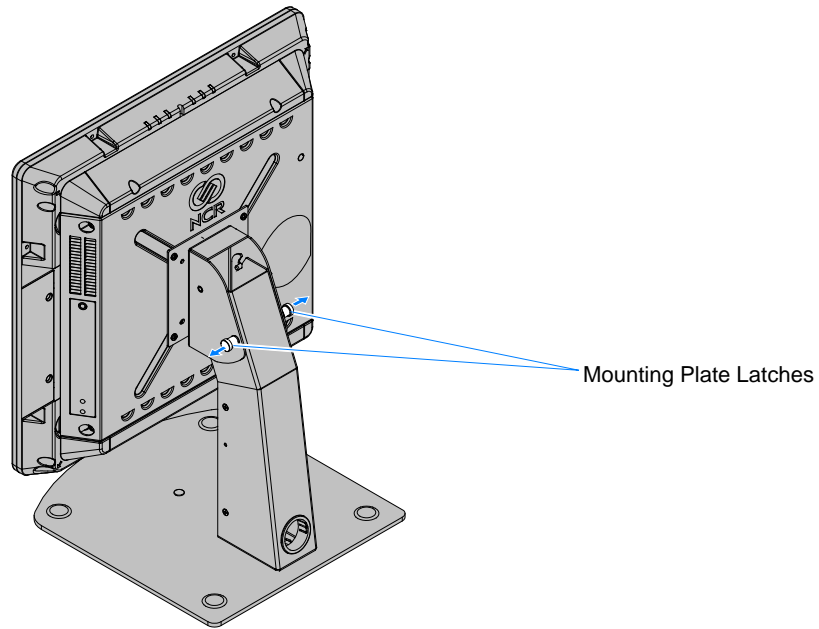

- b. Loosen the captive screw that secures the Cable Cover and remove the cover.

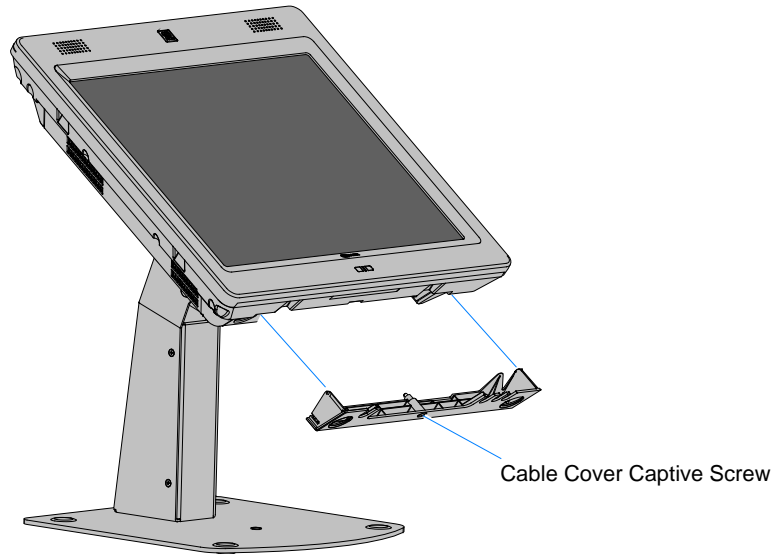

26690

- c. Disconnect the cables from the I/O Panel.

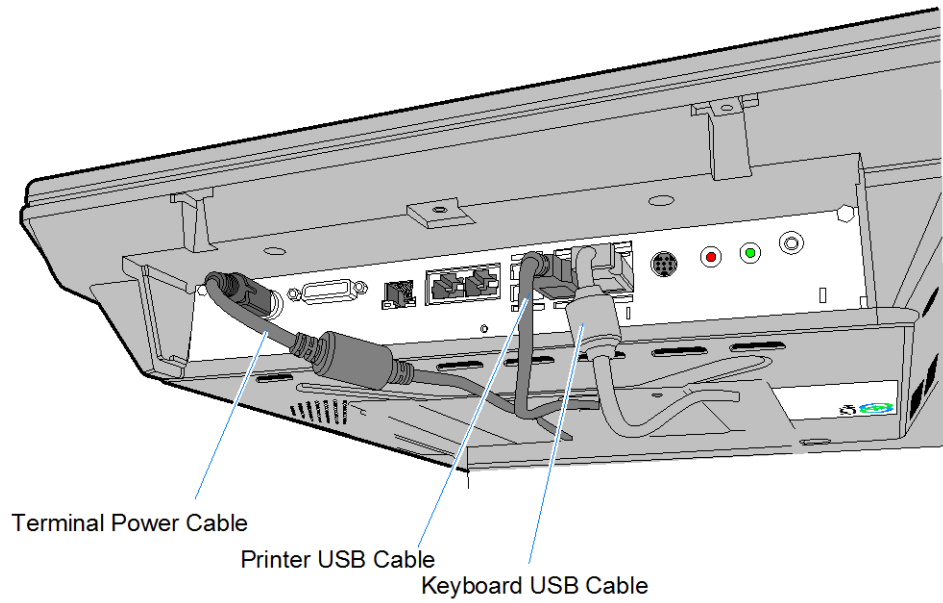

26445a

- d. Release the Mounting Plate Latches and remove the 7409 from the mount.

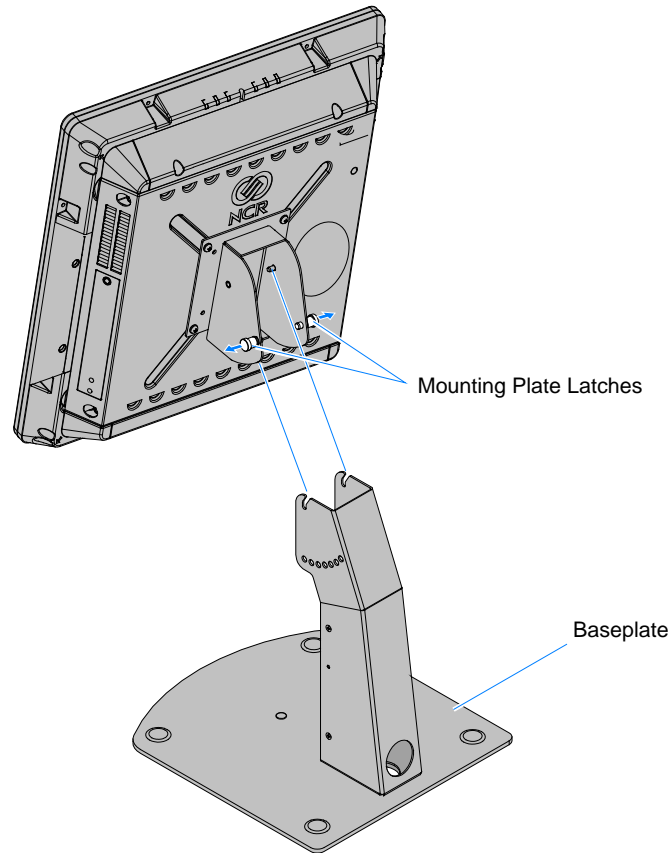

26659

Removing the 7409 from the Fixed Angle Mount

- a. Remove the screws (2) in the sides of the Fixed Angle Mount.

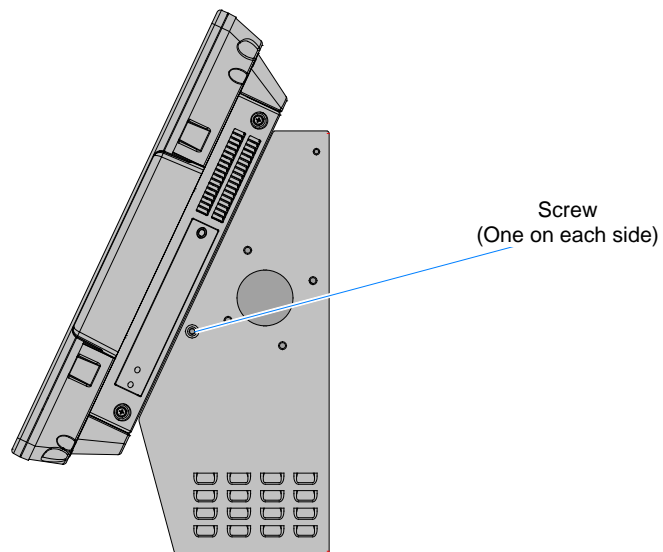

26681

- b. Rest the bottom of the display on the Display Support.

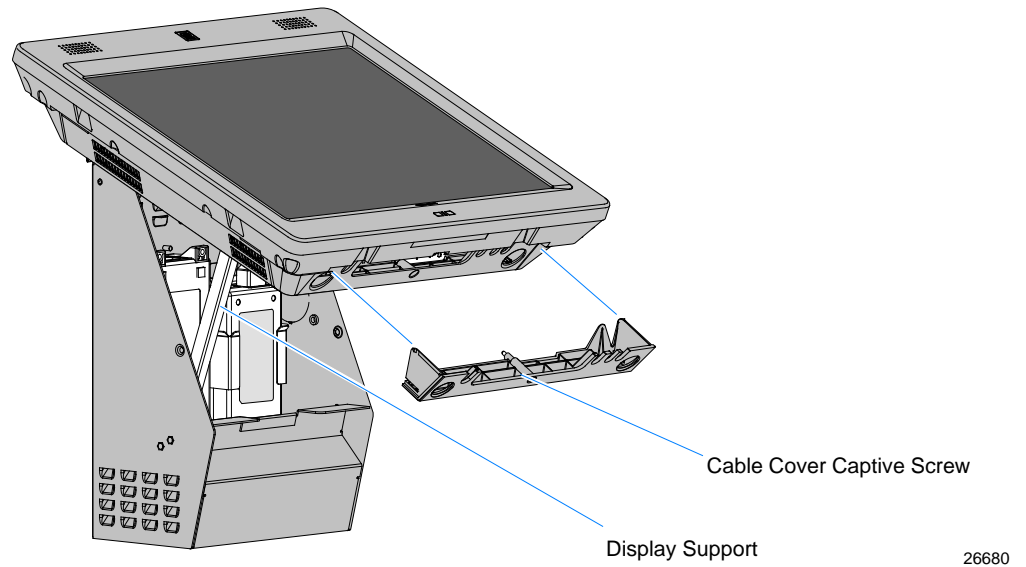

Note: Place the Display Support behind the extension on then Display Hinge Bracket.

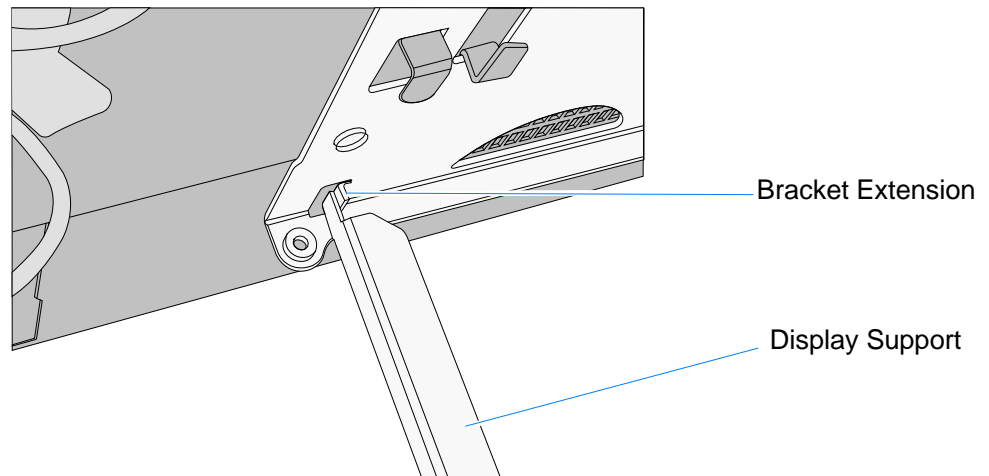

- c. Loosen the captive screw that secures the Cable Cover and remove the cover.

- d. Disconnect the cables from the I/O Panel.

Note: The Power Cable connector *locks* into position when connected to the terminal and cannot be removed by simply pulling on the cable. You must grasp the connector and slide the outside housing out from the terminal to *unlock* it from the terminal connector.

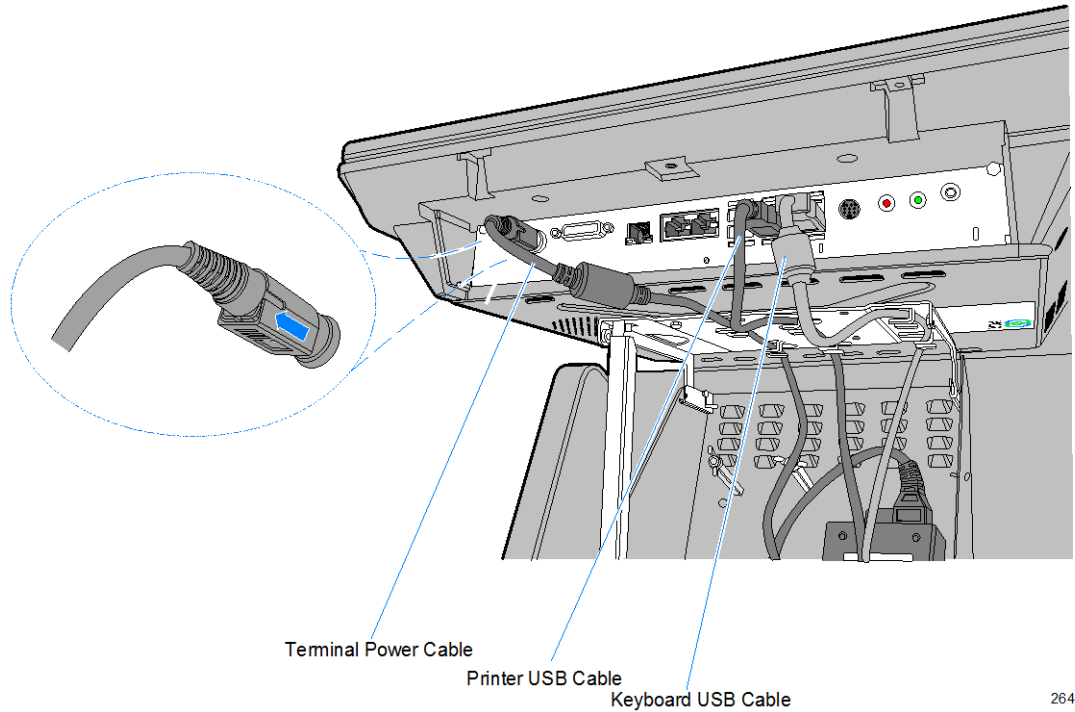

- e. Slide the Locking Brackets (2) to the *unlocked* position.

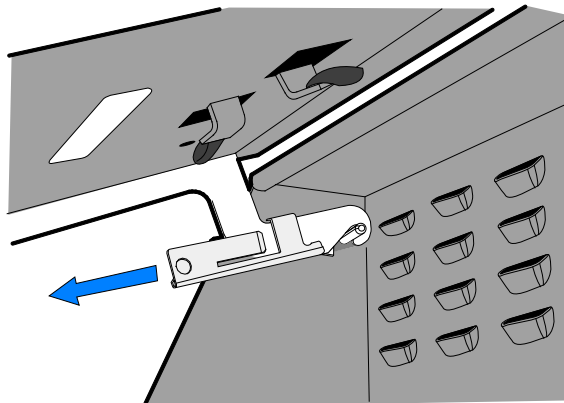

- f. Remove the display from the Fixed Angle Mount.

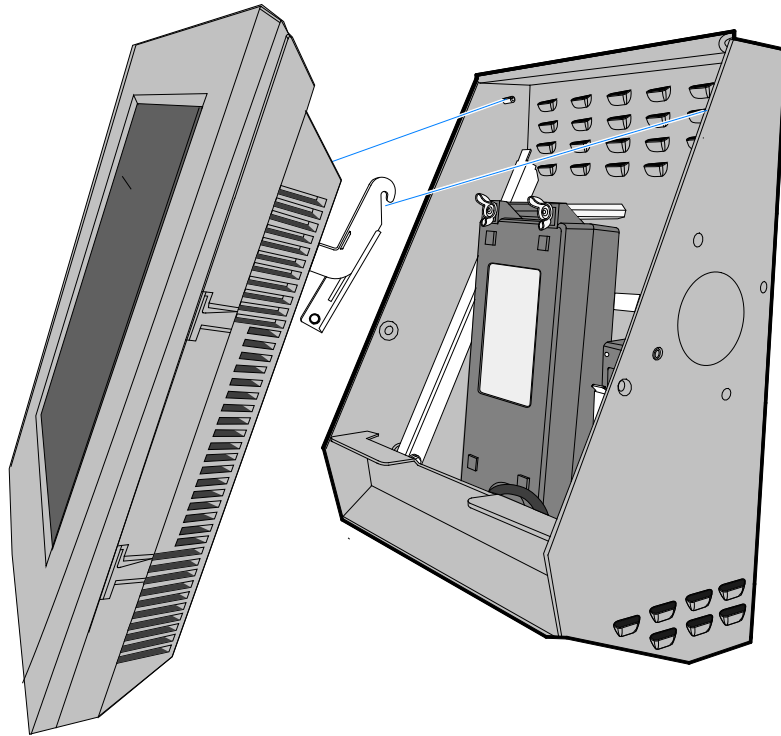

24629

- g. Disconnect the Power Cord from the I/O Panel on the terminal.
2. Lay the terminal face down on a flat surface.
 3. Loosen the captive screws (2) that secure the Rear Cover.

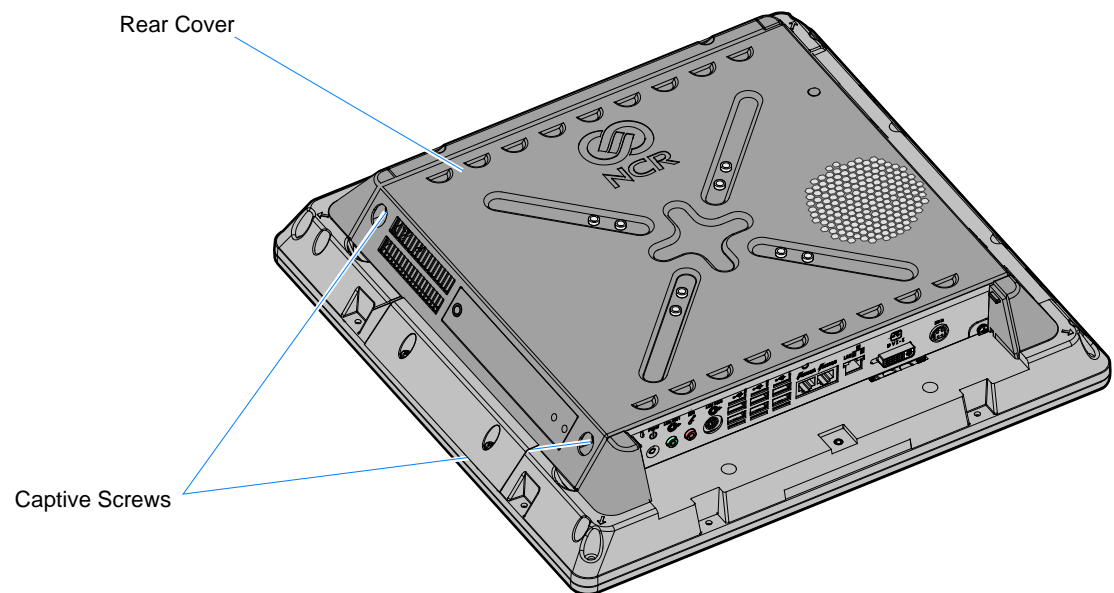

26903

4. Pivot the Rear Cover to the open position.

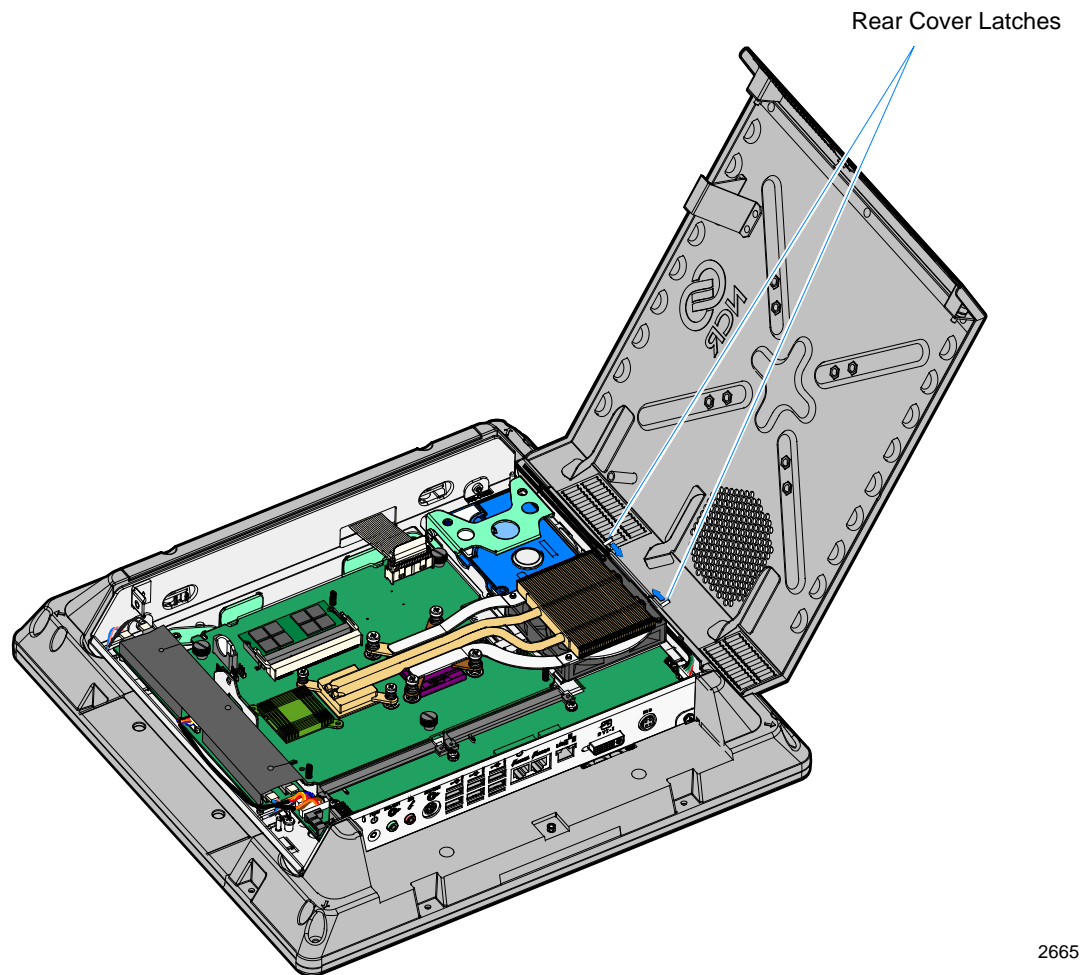

26651a

5. Remove the Rear cover by squeezing the Rear Cover Latches together as indicated above.

6. Remove the No MSR Cover (2 screws).

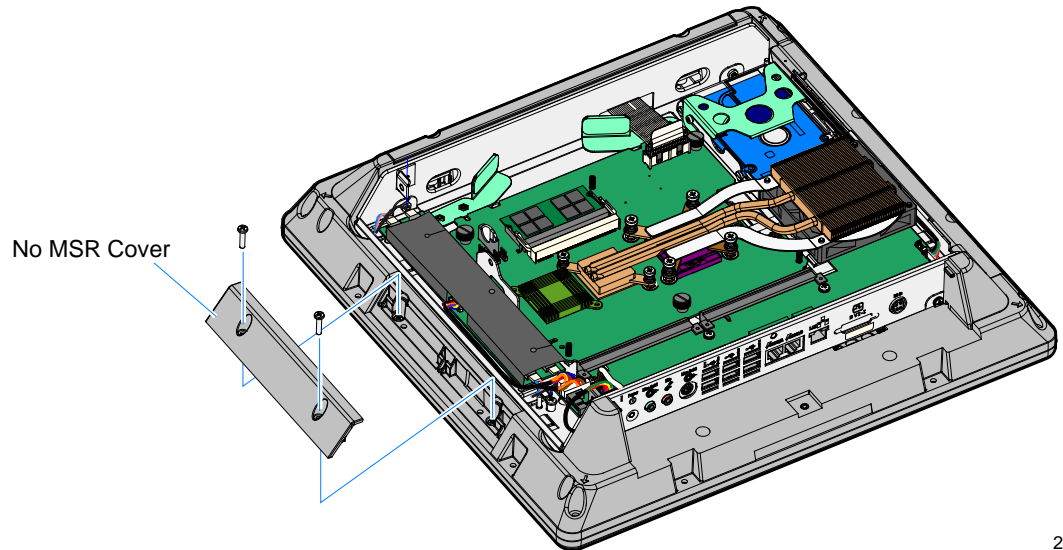

26902

7. Insert the cables into the opening in the chassis and install the MSR Assembly in the slots of the cabinet.

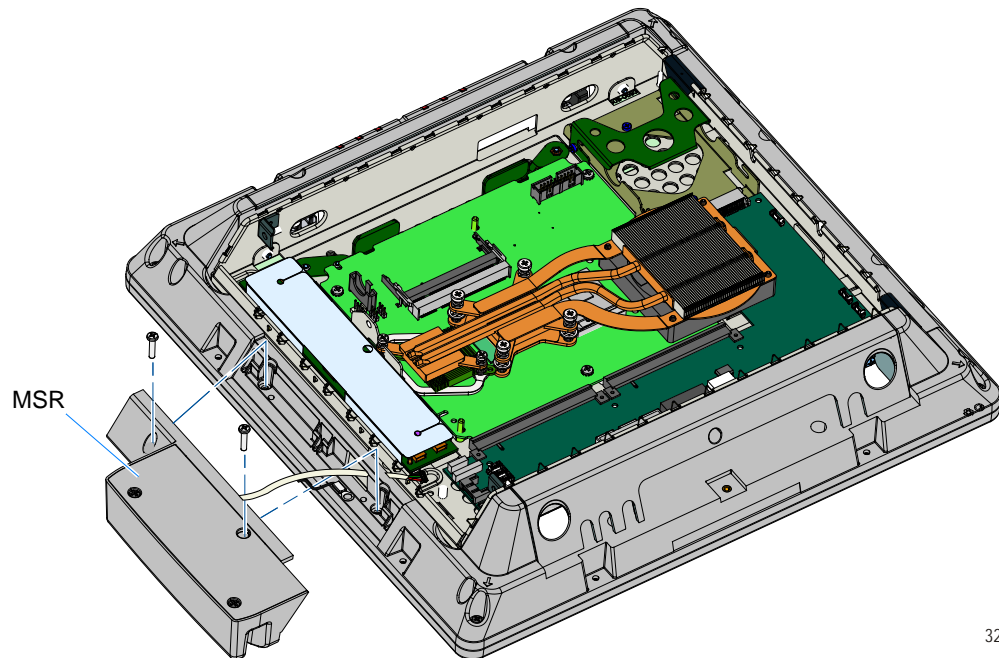

32013

8. Secure the MSR to the chassis (2 screws).

9. Connect the MSR USB Cable to the I/O Board.
10. Connect the MSR Ground Cable to the chassis (screw).

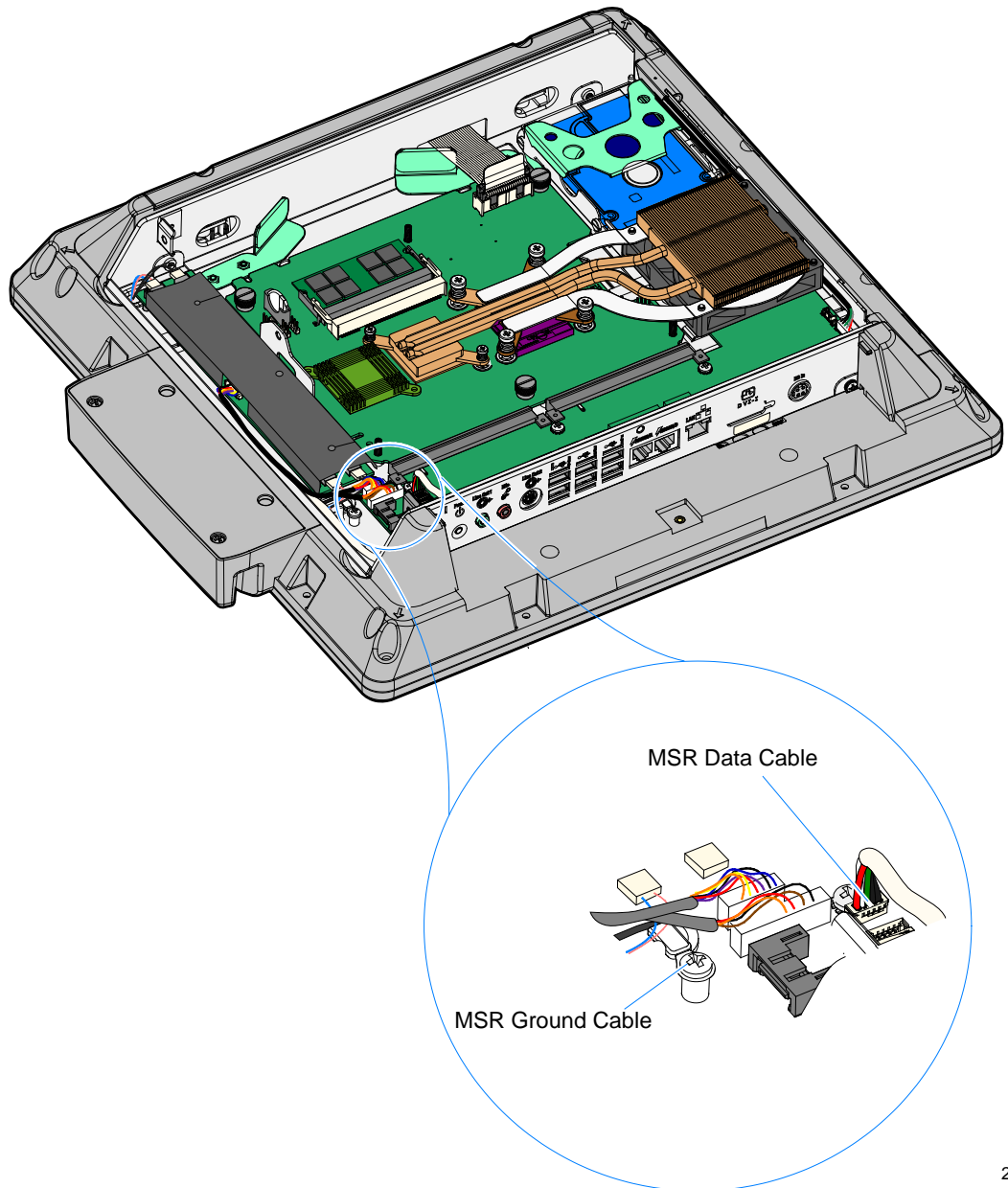

11. Replace the Rear Cover and mount the Display Head to its mount using the reverse procedures.

MSR Programming

If the MSR Module (ISO) is replaced the customer is responsible for re-programming the device to custom wedge-emulation parameters, using the NCR MSR Configuration Utility, which is available on the NCR website at:

<http://www.ncr.com>

1. At this site, select the **Support** tab.
2. Select **Drivers and Patches** → **Retail Support Files** → **NCR RealPOS and SelfServ Terminal and Operating Systems** → **NCR RealPOS 25 (7610)** → **Windows** → **[Operating System]**.
3. Select the *MSR Configuration Utility*.

For information about how to use the utility see the *NCR MSR Configuration Utility User Guide* (B005-0000-2031).