

7409-K002

# Sign Holder

Kit Instructions



Issue B

---

## Revision Record

Issue	Date	Remarks
A	Feb 2009	First issue
B	Aug 2010	Changed Sign Channel quantity to 2

---

## Introduction

This kit provides brackets (2) to hold an information sign on the side, top or bottom of the 7409 terminal.

**Note:** Additional channels (kits) can be used to support a full wrap-around sign.

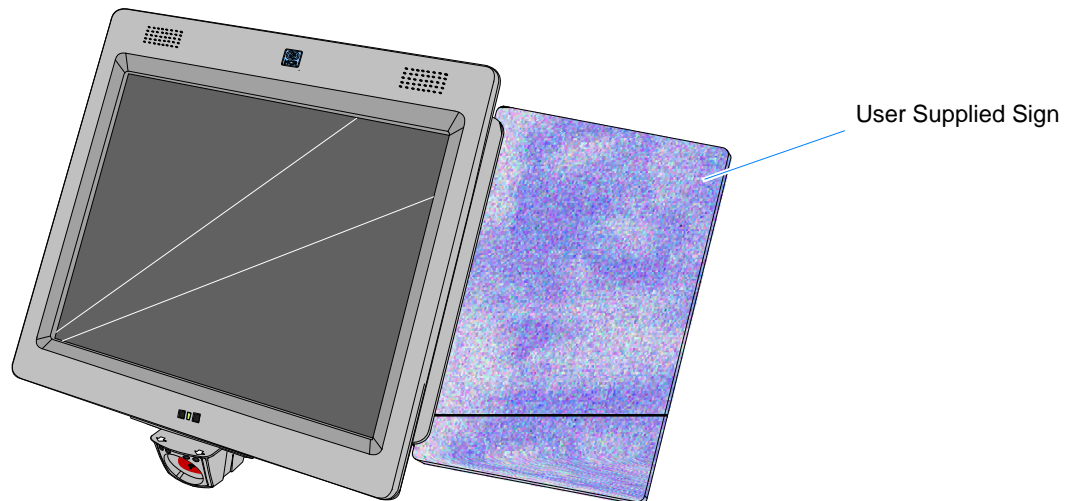
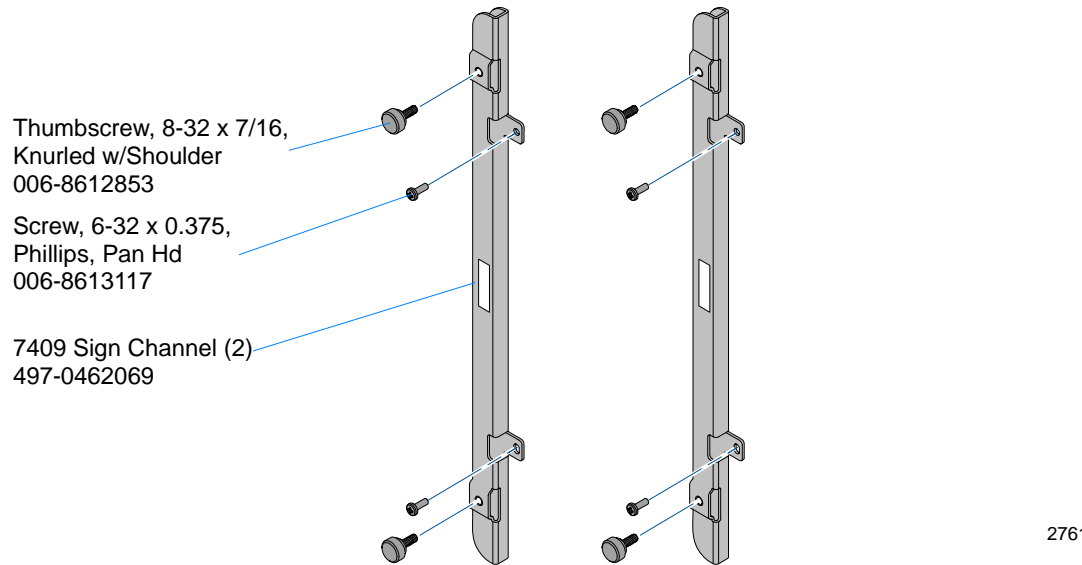

# Installation Procedures

1. Insert the extensions on the bracket into the slots on the preferred edge of the unit.

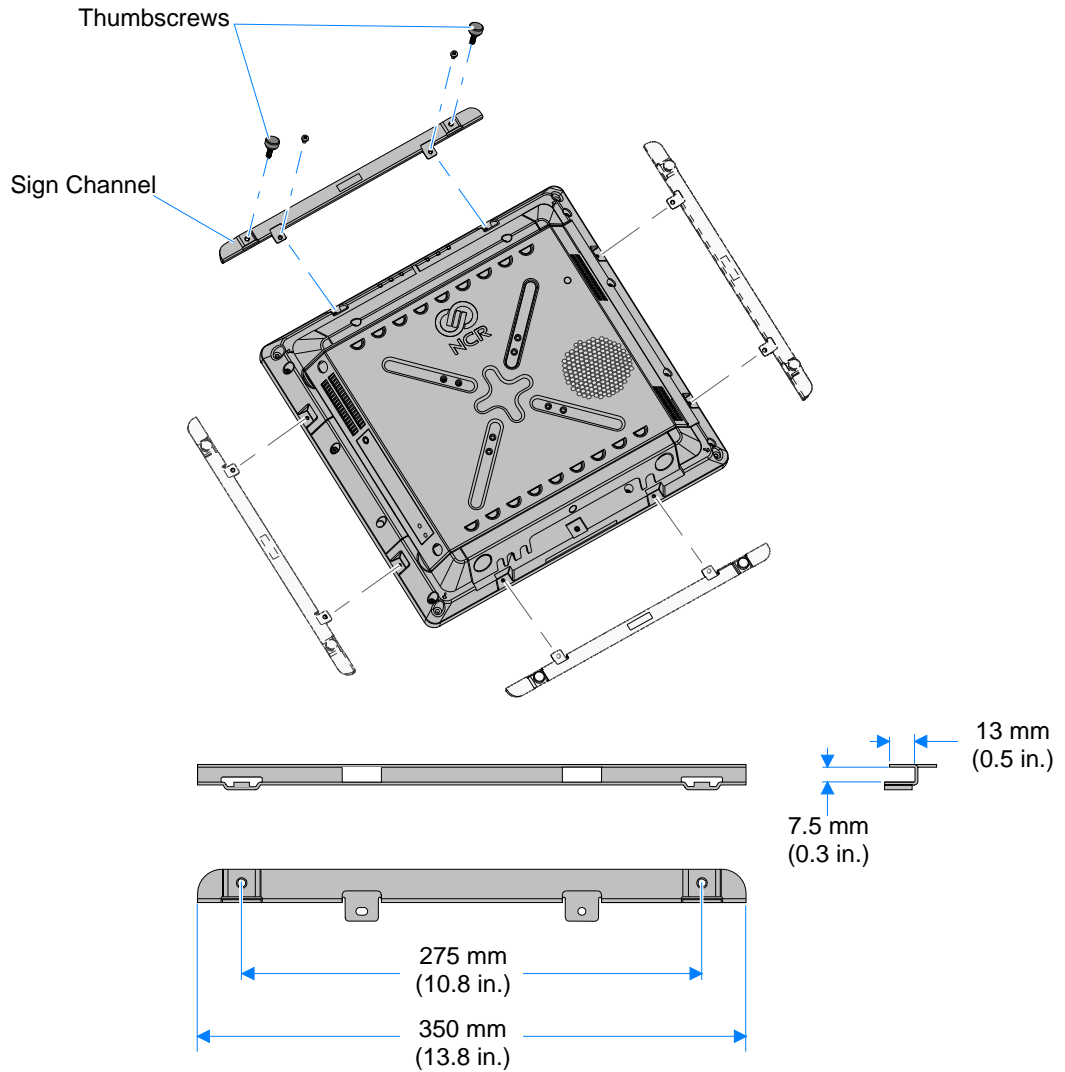

26996

2. Secure the bracket with screws (2).
3. Insert the sign into the bracket and secure it with the two thumbscrews.

## Full Wrap-Around Sign

Two or three channels can be used if it is desirable to install a sign that wraps around the terminal.

1. Install a Sign Channel on each side (and top if necessary) of the terminal as discussed above.
2. Insert the sign into the brackets and secure it with the thumbscrews.

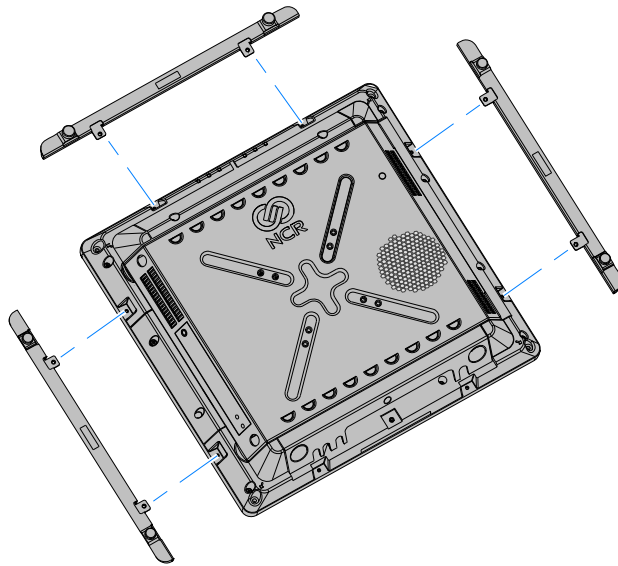

## Dimensions

Use the dimensions below to create the full wrap-around sign. The sign can have a maximum thickness of 6 mm (0.25 in.).

