

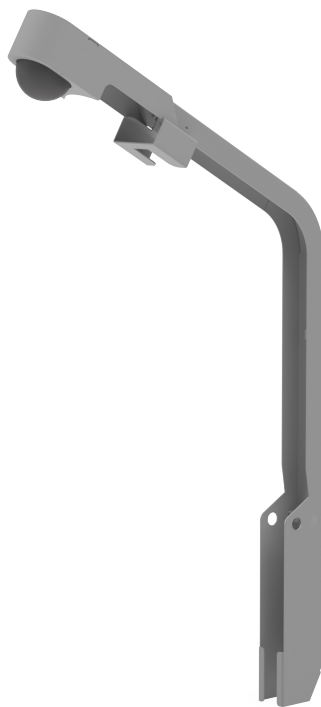

Kit Instructions

IP Camera Field Upgrade (VTC)



7360-K090

Issue A

Copyright

The product described in this document is a licensed product of NCR Corporation.

NCR is a registered trademark of NCR Corporation. NCR [Product] is a trademark of NCR Corporation in the United States and/or other countries. Other product names mentioned in this publication may be trademarks or registered trademarks of their respective companies and are hereby acknowledged.



Java is a registered trademark of Oracle and/or its affiliates.

The terms HDMI and HDMI High-Definition Multimedia Interface, and the HDMI Logo are trademarks or registered trademarks of HDMI Licensing LLC in the United States and other countries.

Where creation of derivative works, modifications or copies of this NCR copyrighted documentation is permitted under the terms and conditions of an agreement you have with NCR, NCR's copyright notice must be included.

It is the policy of NCR Corporation (NCR) to improve products as new technology, components, software, and firmware become available. NCR, therefore, reserves the right to change specifications without prior notice.

All features, functions, and operations described herein may not be marketed by NCR in all parts of the world. In some instances, photographs are of equipment prototypes. Therefore, before using this document, consult with your NCR representative or NCR office for information that is applicable and current.

Copyright © 2024
By NCR Voyix Corporation
Global Headquarters
864 Spring St. NW
Atlanta, GA 30308
United States
All Rights Reserved

Confidential and proprietary information of NCR Voyix Corporation.
Unauthorized use, reproduction and/or distribution is strictly prohibited.

Revision Record

Issue	Date	Remarks
A	Feb 2024	<ul style="list-style-type: none">• First issue.• Updated with IP-Guild Styles.

IP Camera Field Upgrade (VTC)

This publication provides procedures for installing the Tri-Light/Lane Light with IP Camera Enhanced (VTC) Field Upgrade to the following units:

- NCR FastLane SelfServ™ Checkout (7360)
- NCR FastLane SelfServ™ Checkout (7358)
- NCR FastLane SelfServ™ Checkout (7357)

Kit Contents

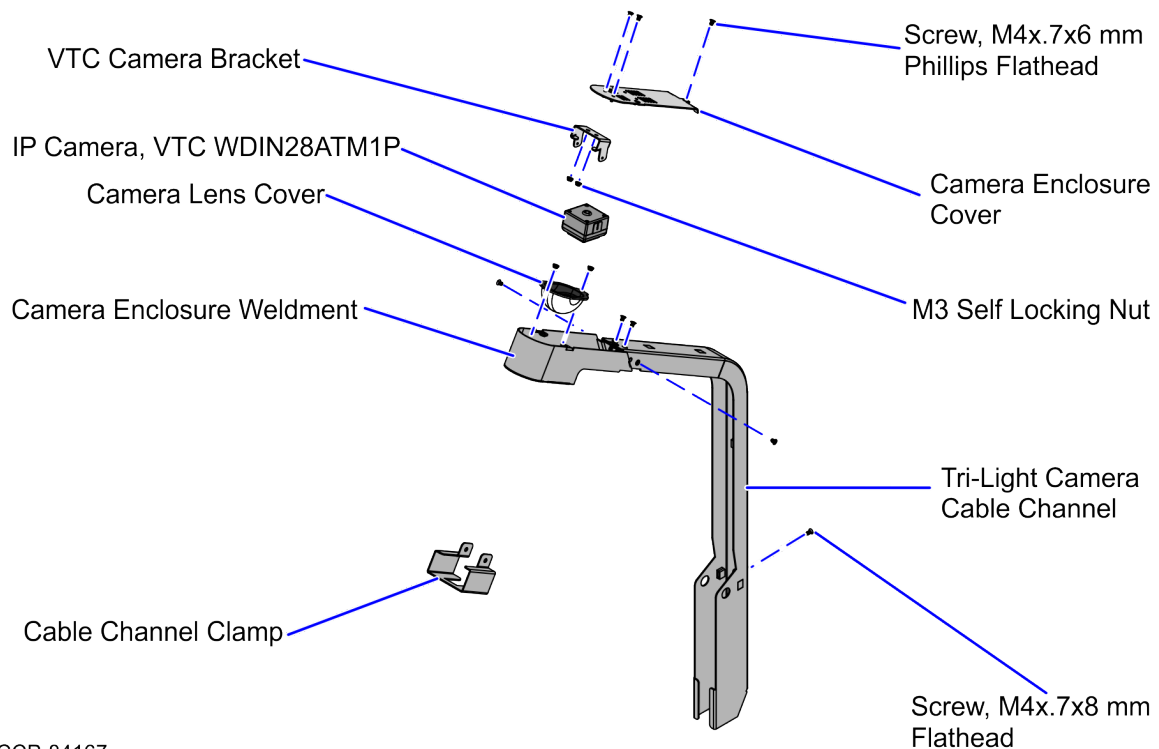

CCP-84167

Part Number	Description
497-0535788	Kit - Tri-light w/ IP Cam Enhanced (VTC) Field Upgrade
497-0535454	Tri-Light Camera Cable Channel
497-0535455	Cable Channel Clamp
006-8623633	Machine Screw, Flat Head Phillips Zinc-Plated Steel, M4 Size, 6mm Length, .7mm Pitch (7 pcs)

Confidential and proprietary information of NCR Voyix Corporation.
 Unauthorized use, reproduction and/or distribution is strictly prohibited.

Part Number	Description
497-0535703	Camera Bracket - VTC
497-0532349	IP Camera - PoE/12V, VTC WDIN28ATM1P, 2MP, 2.8mm Lens
006-8628746	Nut M3 Self Locking (4 pcs)
006-8624498	Screw - M4x.7x8mm, Flat head, Stainless
* 497-0519622	Label - Hole Cover, Mid-Silver (3 pcs)
497-0535450	Weldment - Camera Enclosure
497-0535451	Cover - Camera Enclosure
497-0535452	Camera Lens Cover
006-8628729	Tie Strap Plain 5.60 LG (8 pcs)
* 497-0423108	Instructions - Kit (Reference Sheet)

* Items marked with an asterisk are not called out on the image.

Customer Supplied Devices

The following devices must be supplied by the customer:

- 802.3at (PoE+) Compatible Switch/Injector
- Ethernet (LAN) Cable

Installation Procedure

To install the IP Camera Field Upgrade (VTC), follow these steps:



Note

Ensure that the NCR Customer Helpdesk is informed when the Tri-Light/Lane Light with IP Camera is installed in the store.

1. Remove the existing Tri-Light/Lane Light Assembly. For more information, refer to [Removing the Tri-Light/Lane Light \(R6\) on the next page](#).
2. Install the IP Camera (VTC) to the Tri-Light/Lane Light Assembly, refer to [Installing the IP Camera on page 10](#).
3. Install the Tri-Light with IP Camera Assembly. For more information, refer to [Installing the Tri-Light/Lane Light with IP Camera Assembly on page 13](#).
4. Configure the Camera Settings. For more information, refer to [Configuring the Camera Settings \(VTC\) on page 52](#).



Note

For more information about setting up the camera, refer to [VTC Network Camera User Manual](#).

Removing the Tri-Light/Lane Light (R6)

To remove the Tri-Light/Lane Light Assembly, follow these steps:

1. Turn off the NCR SelfServ Checkout software and hardware systems.
2. Remove one (1) screw to detach the Tri-Light/Lane Light Assembly to the Tri-Light/Lane Light pole.

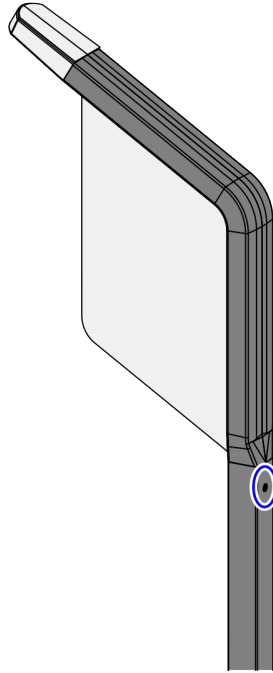

CCP-62078

3. Lift the Tri-Light/Lane Light Assembly and then disconnect the cables.



Tip

Mark all cables as to where they are connected to quickly determine the corresponding port when reconnecting the cables.

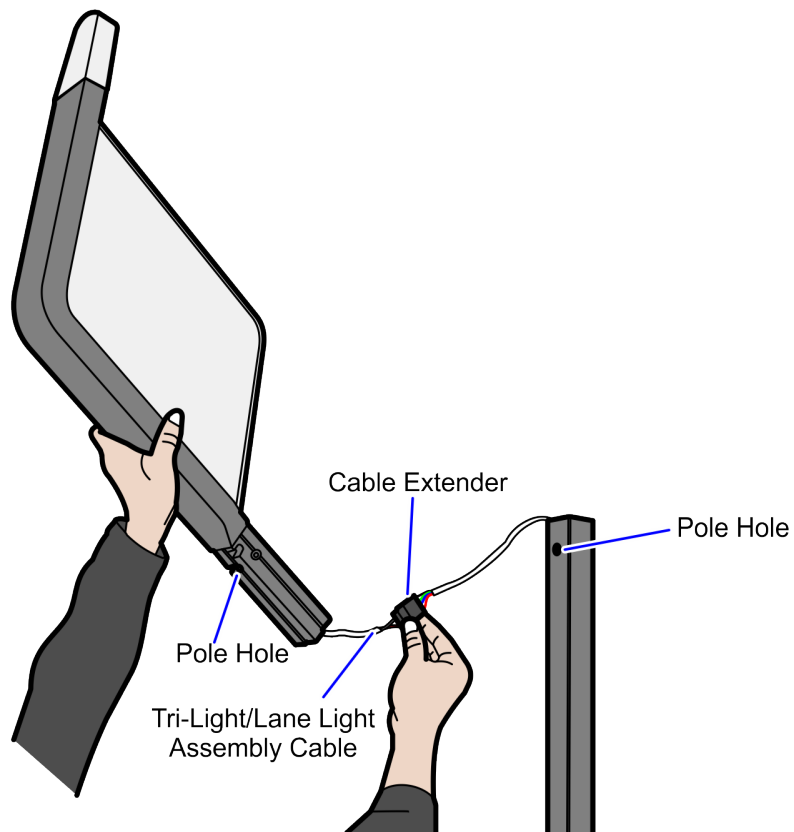

CCP-62080

Installing the IP Camera

To install the IP Camera to the Tri-Light/Lane Light Assembly, follow these steps:

1. Remove the existing Tri-Light/Lane Light Assembly. For more information, refer to [Removing the Tri-Light/Lane Light \(R6\) on page 8](#).
2. Connect the LAN Cable to the IP Camera.
3. Secure the LAN Cable to the Tri-Light Cable Channel using three (3) cable ties, as shown in the image below.

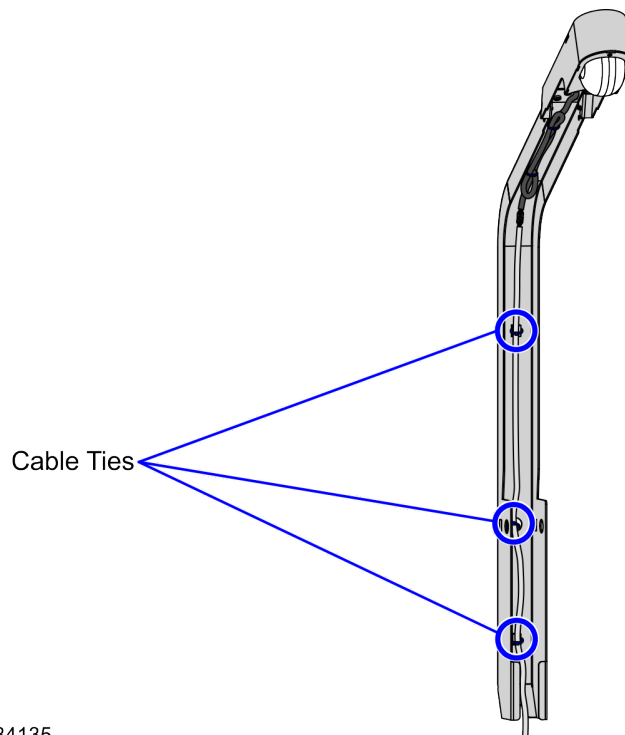

CCP-84135

- Slide the Tri-Light Cable Channel Clamp on the Tri-Light/Lane Light Assembly.

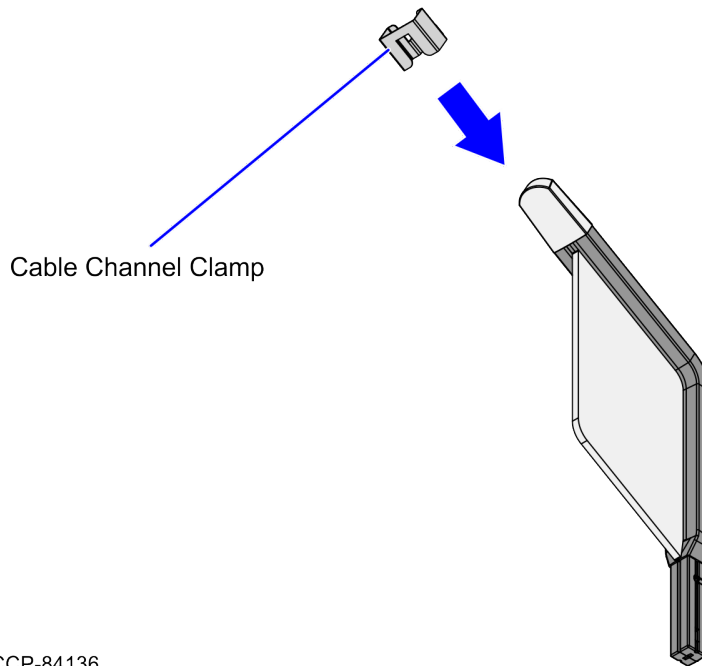

- Slide the Tri-Light Cable Channel Assembly on the Tri-Light/Lane Light Assembly with Cable Channel Clamp.

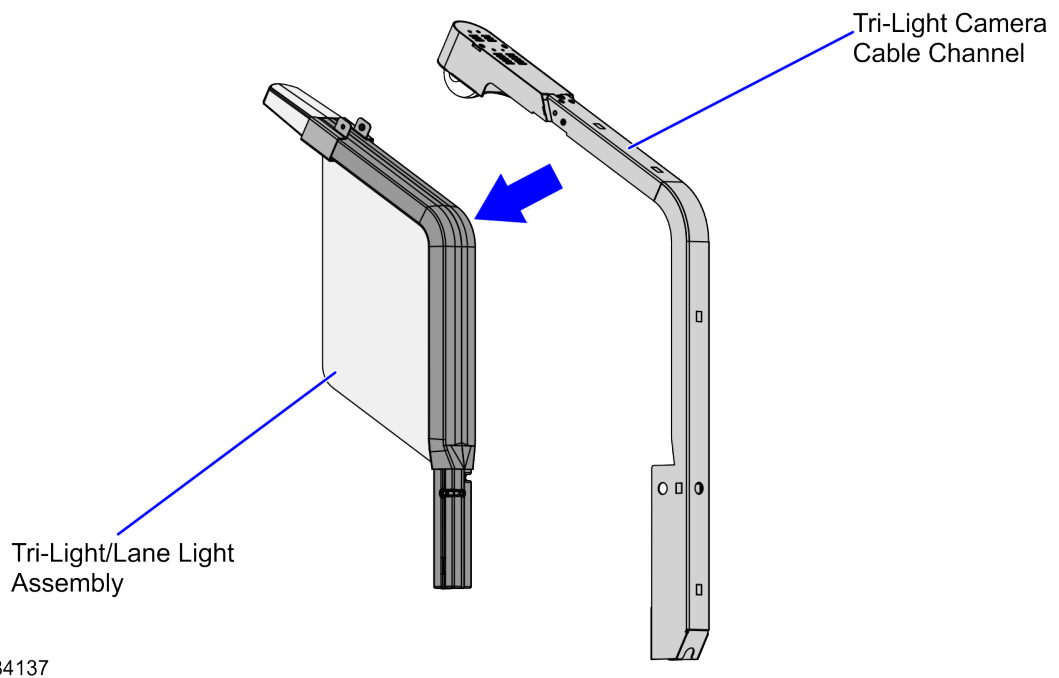

- Secure the Tri-Light Cable Channel to the Tri-Light/Lane Light Assembly using two (2) screws.

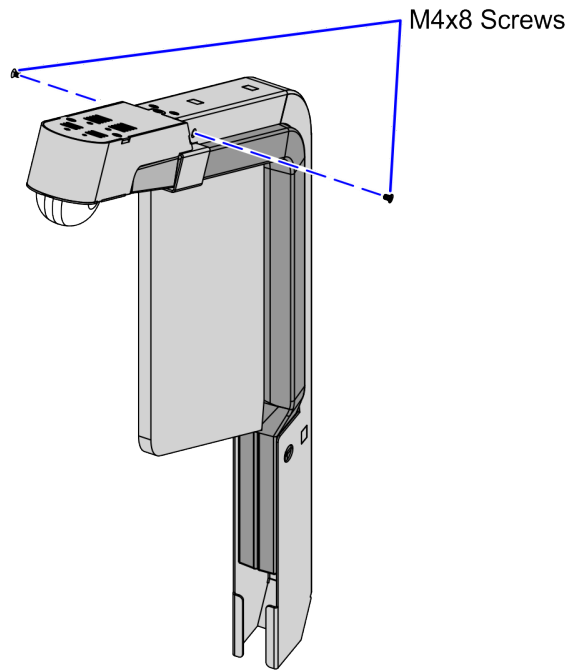

CCP-84138

Installing the Tri-Light/Lane Light with IP Camera Assembly

To install the new Tri-Light/Lane Light with IP Camera Assembly, follow these steps:

i Note
Ensure that the NCR Customer Helpdesk is informed when the Tri-Light/Lane Light with IP Camera is installed in the store.

1. Do the following:
 - a. Route the LAN Cable into the Tri-Light/Lane Light Pole.
 - b. Connect the Tri-Light/Lane Light Cable to the cable extender.

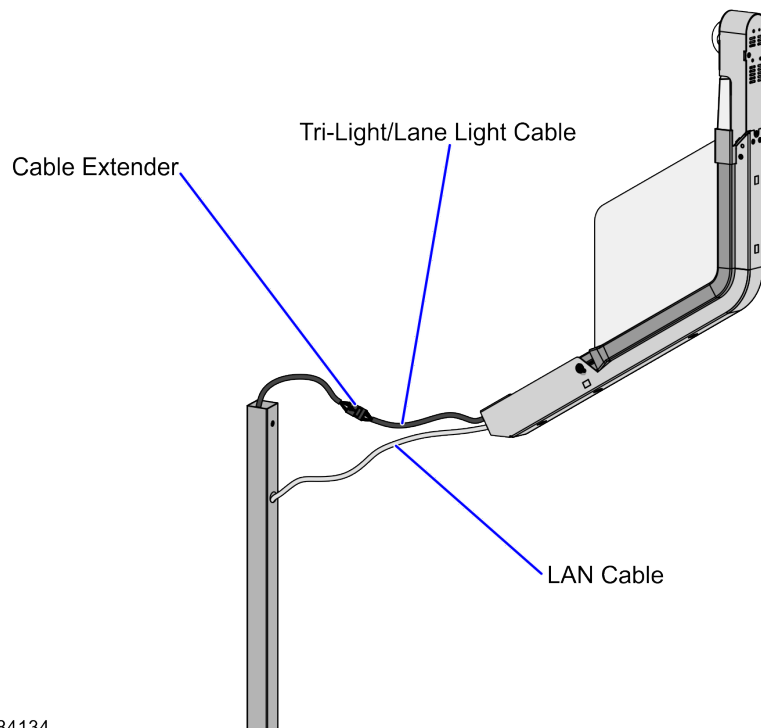

CCP-84134

2. Orient the Tri-Light/Lane Light Assembly so that the Lane Light faces the front of the unit.
3. Insert the Tri-Light/Lane Light Assembly into the Tri-Light/Lane Light Pole.

i Note
Ensure the pole holes are aligned and that the LAN Cable and the Tri-Light/Lane Light Cable do not intertwine when installing the Tri-Light/Lane Light assembly to the Tri-Light/Lane Light Pole.

- Route and connect the Tri-Light/Lane Light and LAN cables to the corresponding port destinations:

i Note
For more information on routing cables, refer to [Routing the Cables on page 16](#).

Tri-Light	Destination Connection (Location)
Cable Extender	I/O Box (Tri-Light/Lane Light port)
Ethernet (LAN) Cable	PoE Switch

i Note
Ensure that the Camera uses an 802.3at (PoE+) compatible Switch/Injector.

- Secure the Tri-Light/Lane Light Assembly to the pole using one (1) screw.

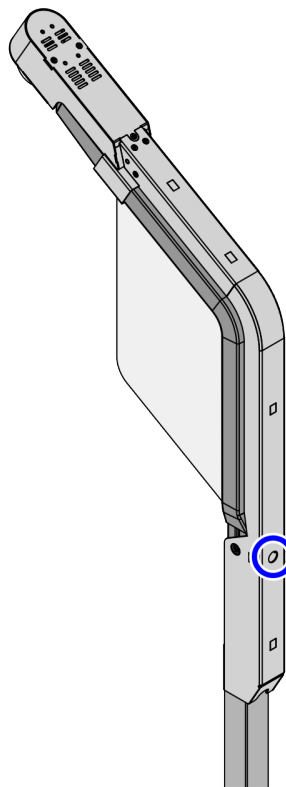

CCP-84169

6. Attach three (3) Label-Hole Covers to the holes on the Tri-Light/Lane Light, as show in the image below.

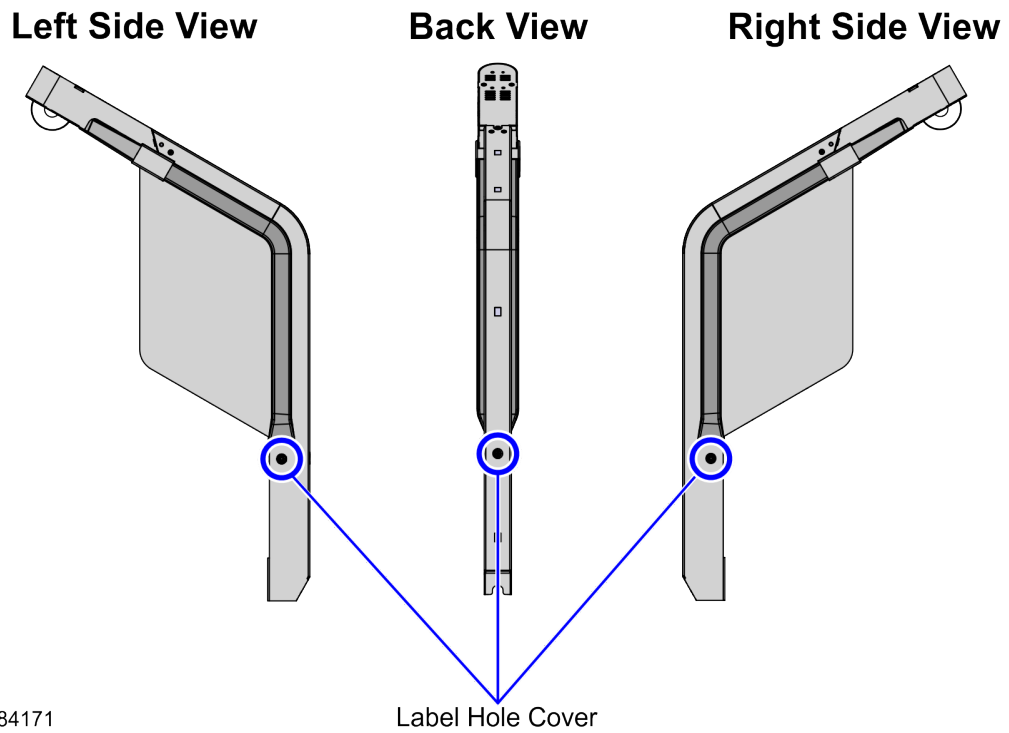

CCP-84171

Routing the Cables

The steps for routing the Tri-Light/Lane Light and LAN cables depend on the SelfServ Checkout configuration. For more information, refer to the following procedures:

- [Routing the Cables: 7360 R6-C Full Function \(Fixed\) on the next page](#)
- [Routing the Cables: 7360 R6-C Full Function \(Convertible\) on page 25](#)
- [Routing the Cables: 7360 R6-C \(Card Only\) on page 33](#)
- [Routing the Cables: 7357 R6LN Plus on page 40](#)
- [Routing the Cables: 7358 R6L Plus on page 46](#)

Routing the Cables: 7360 R6-C Full Function (Fixed)

To route the Tri-Light/Lane Light Cable and LAN Cable in the Full Function (Fixed) unit, follow these steps:

1. Do the following:
 - a. From the Tower Frame pole duct, route the Tri-Light/Lane Light Cable through the built-in hooks inside the Tower Frame.
 - b. Route the cable down the Scanner Bucket floor. Use cable ties to secure the cable on the bridge lances.
 - c. Secure the cable to the anchor using a cable tie.

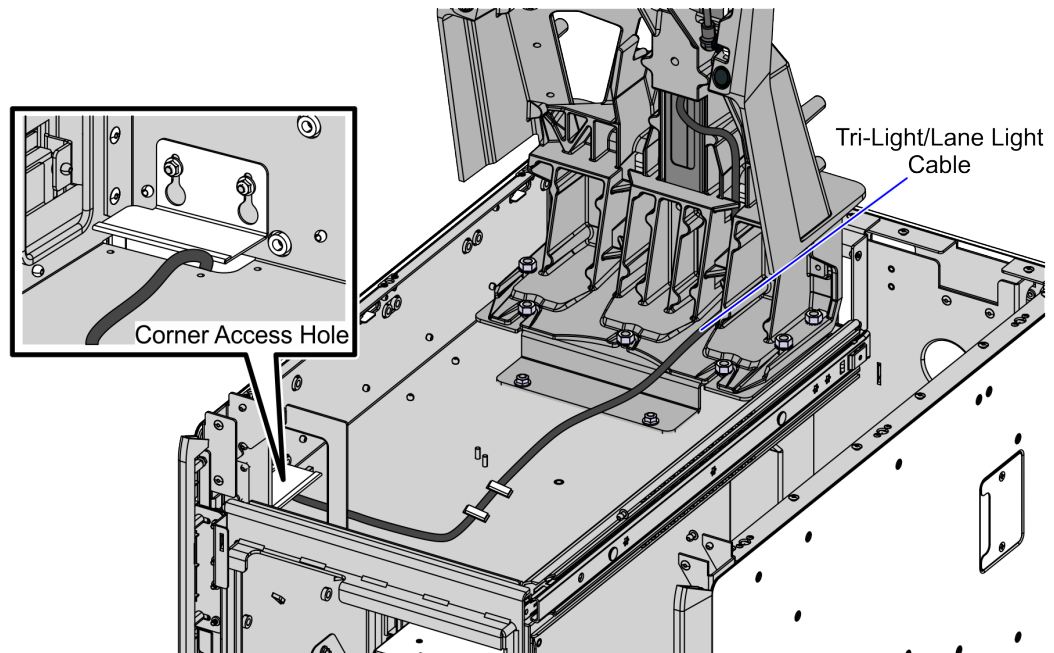

CCP-82464

2. Route the Tri-Light/Lane Light Cable by doing the following:
 - a. From the corner cable access hole, route the cable down the Core Cabinet wall and use cable ties to secure the cables on the bridge lances.
 - b. Connect the cable to the Tri-Light/Lane Light port of the I/O Box.

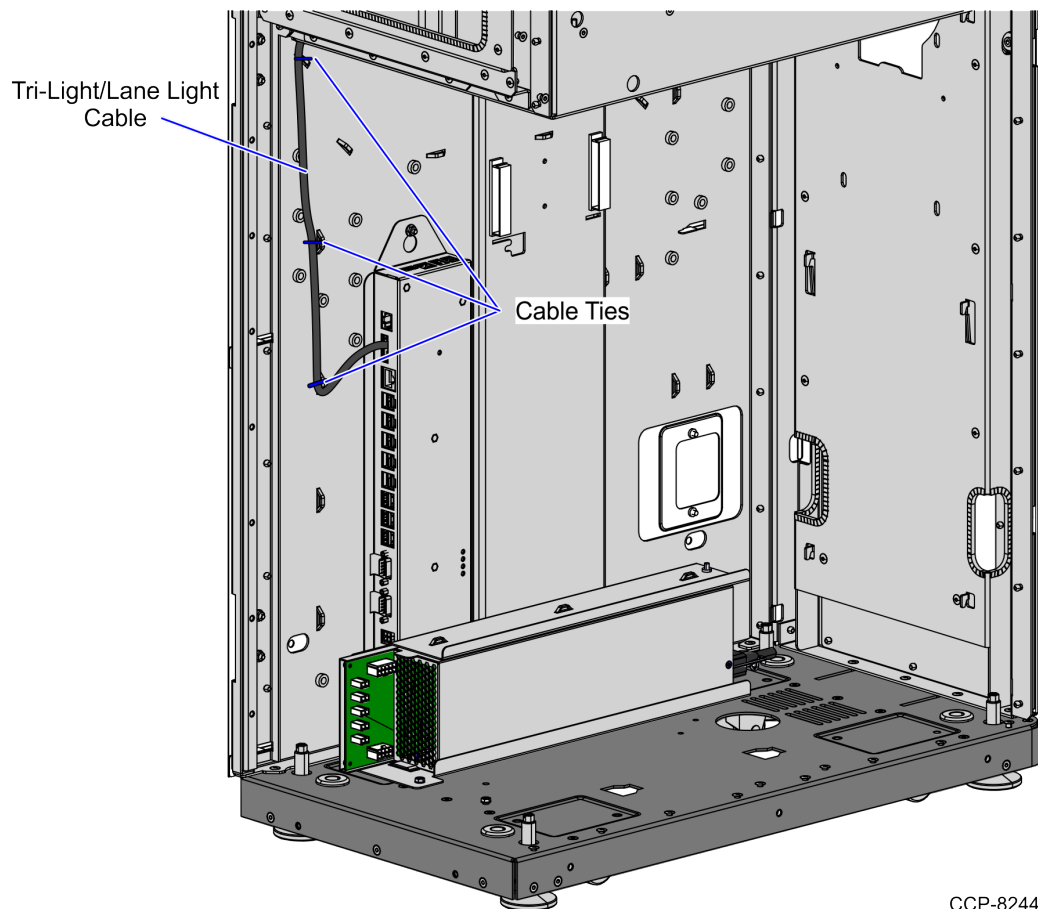

CCP-82446

3. Route the LAN Cable. Depending on the configuration, refer to the following:
 - [Routing the LAN Cable: No-Bag Unit on the next page](#)
 - [Routing the LAN Cable: Left-Hand Unit on page 21](#)
 - [Routing the LAN Cable: Right-Hand Unit on page 23](#)

Routing the LAN Cable: No-Bag Unit

To route the LAN Cable, follow these steps:

1. Do the following:
 - a. From the Tower Frame pole duct, route the cable down through the built-in hooks inside the Tower Frame.
 - b. Route the cable down the Scanner Bucket floor. Use cable ties to secure the cable on the bridge lances.
 - c. Secure the cables to the anchor using a cable tie.

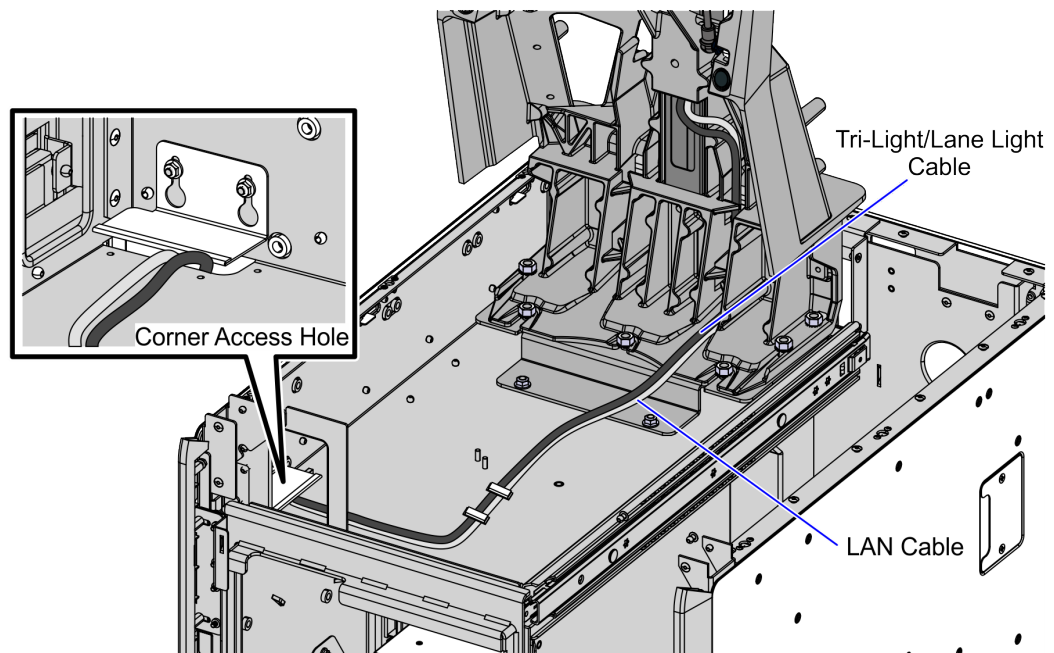

CCP-82445

2. From the corner cable access hole, route the cable down the Core Cabinet wall and down the bottom exit hole, as shown in the image below.

i Note
Pass the cable through cable clamps and secure the cable on the bridge lances using cable ties.

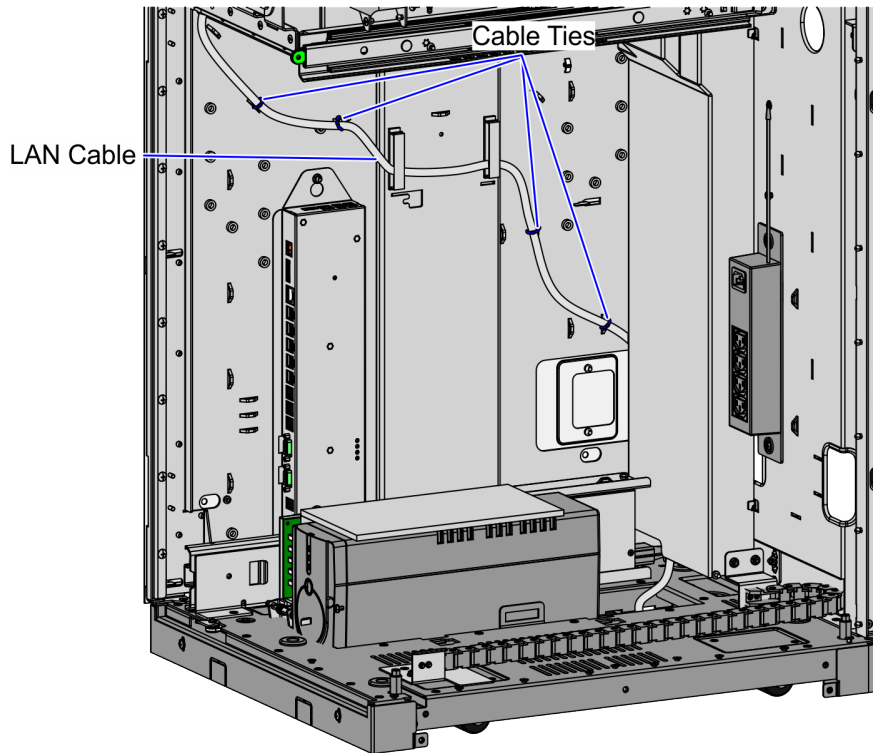

CCP-82487

3. Connect the cable to the PoE Switch.

Routing the LAN Cable: Left-Hand Unit

To route the LAN Cable, follow these steps:

1. From the Tri-Light/Lane Light Pole, route cable down the Scanner Bucket and out through the rear cable access hole.

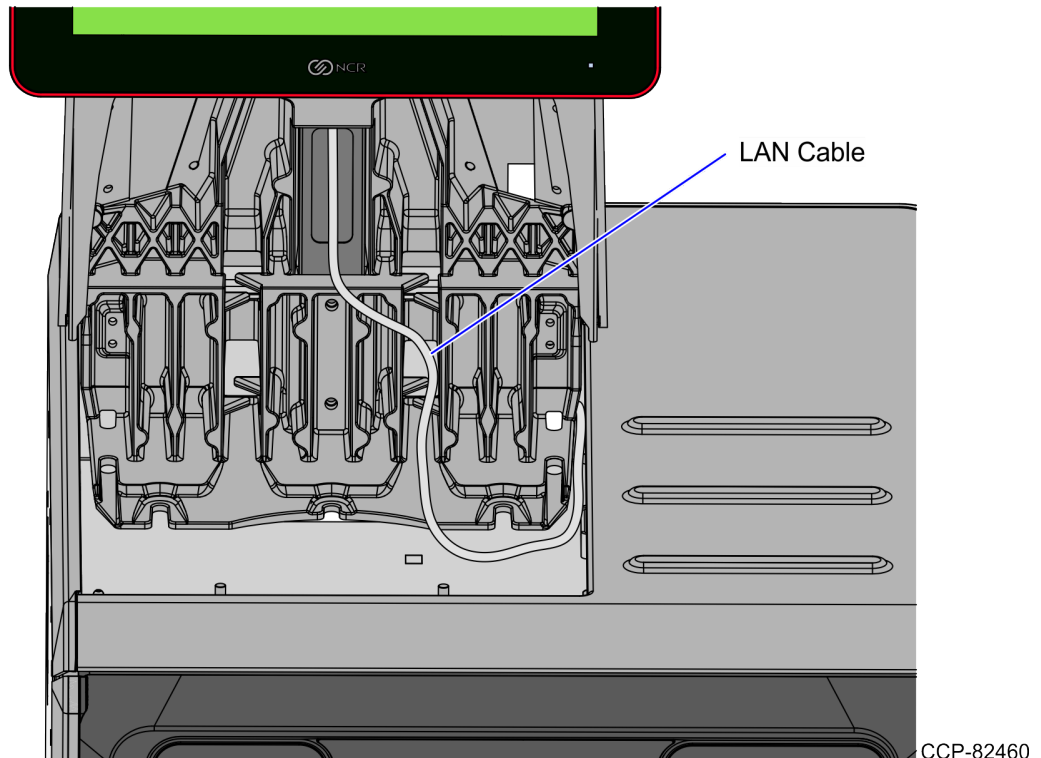

2. From the rear cable access hole, route the cable down the rear of the Core Cabinet and into the Bagwell through the left side cable exit hole. Use cable ties to secure the cable to the lance bridges.

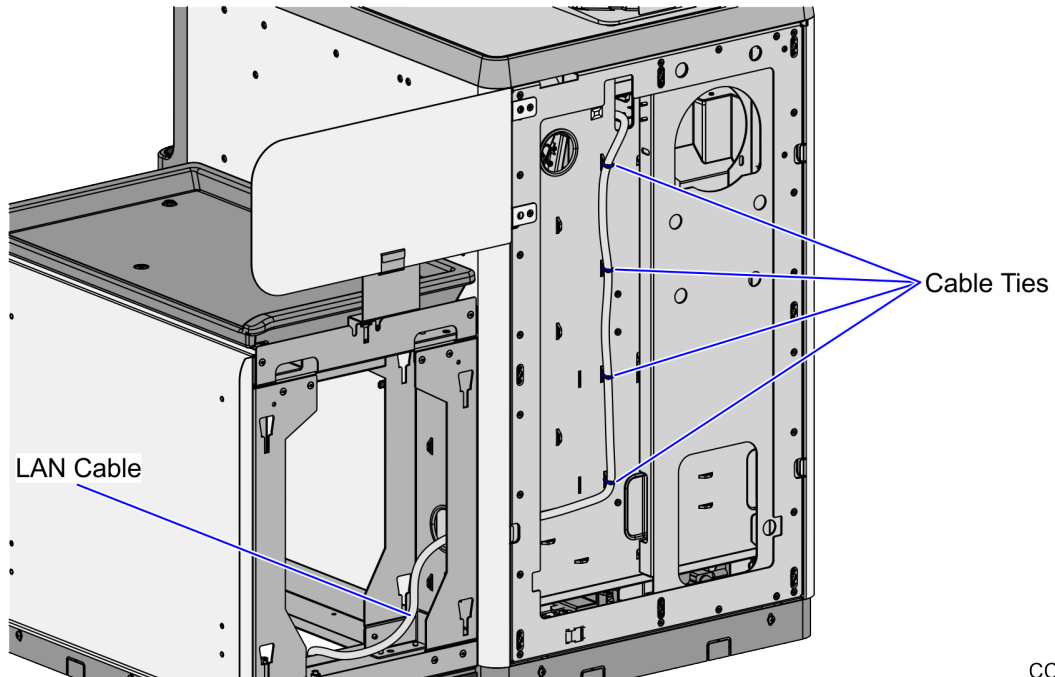

CCP-82462

3. Continue to route the cable out through the bottom cable exit hole and connect it to the PoE Switch.

Routing the LAN Cable: Right-Hand Unit

To route the LAN Cable, follow these steps:

1. From the Tri-Light/Lane Light Pole, route the cable down the Scanner Bucket and out through the rear cable access hole.

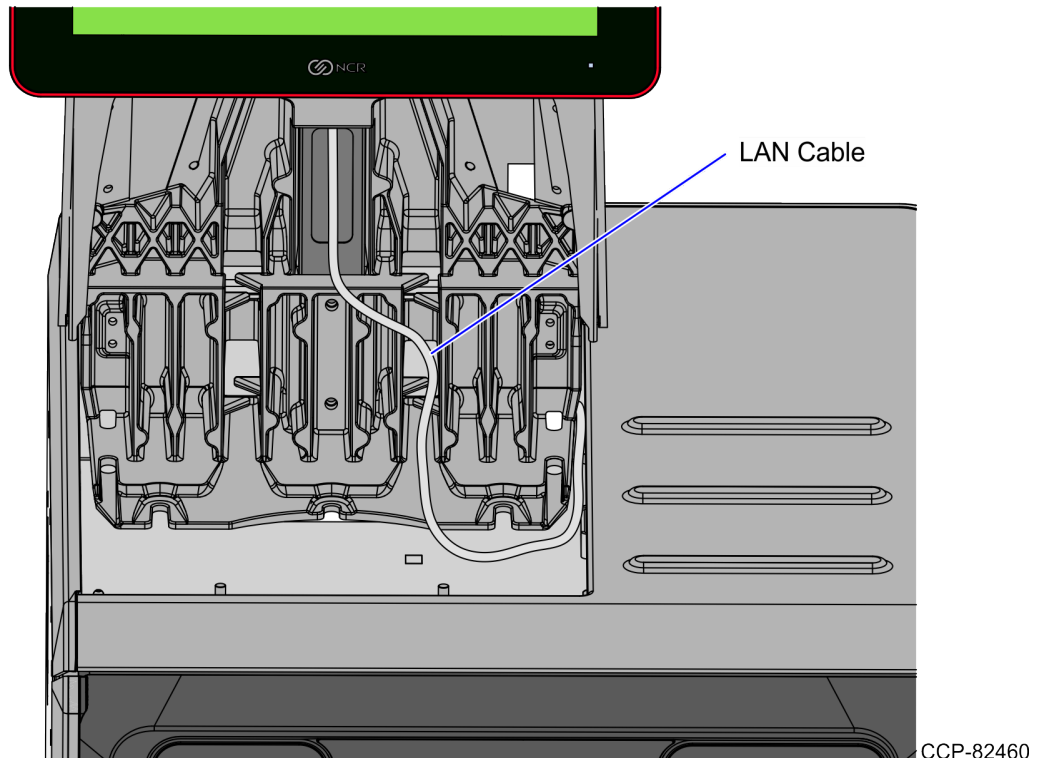

2. From the rear cable access hole, route the cable down the rear of the Core Cabinet and into the Bagwell through the right side cable exit hole. Use cable ties to secure the cable to the lance bridges.

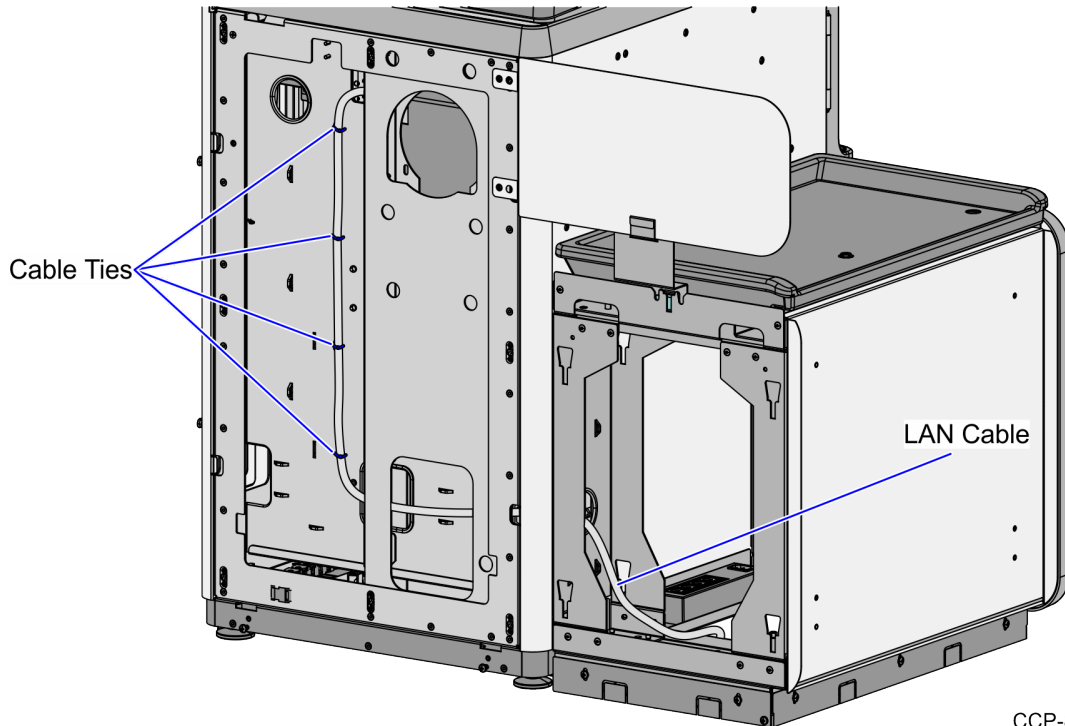

CCP-82482

3. Continue to route the cable out through the bottom cable exit hole and connect it to the PoE Switch.

Routing the Cables: 7360 R6-C Full Function (Convertible)

To route the Tri-Light/Lane Light Cable and LAN Cable in the 7360 Full Function (Convertible) unit, follow these steps:

1. Do the following:
 - a. From the Tower Frame pole duct, route the Tri-Light/Lane Light Cable and the LAN Cable down through the built-in hooks inside the Tower Frame.
 - b. Route the cables down the opening of the Scanner Lift Assembly along the Spiral Management Cable.
 - c. Secure the cables by placing cable ties on every notch on the Spiral Management Cable.

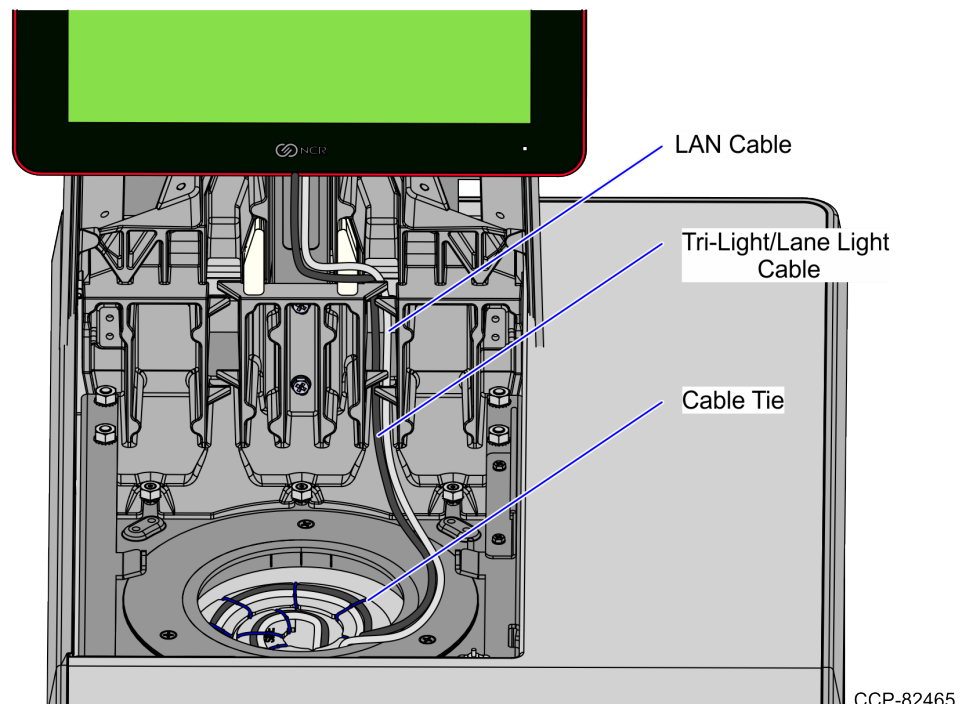

- d. Continue to route the cables into the corner cable access hole.

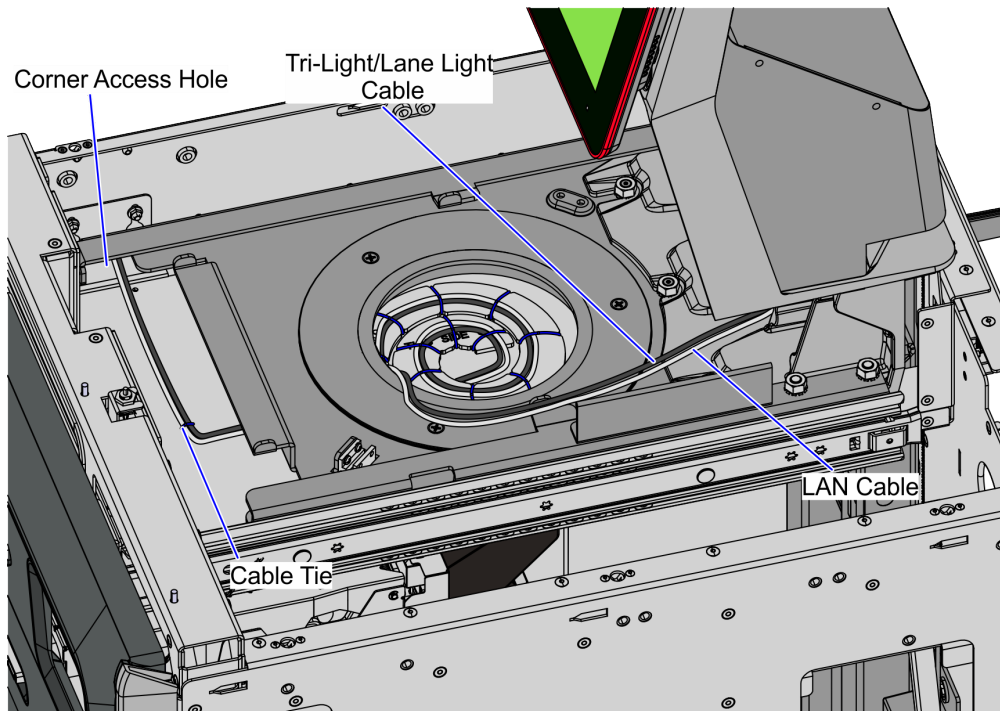

CCP-82466

2. Route the Tri-Light/Lane Light Cable by doing the following.
- From the corner cable access hole, route the cable down the Core Cabinet wall and use cable ties to secure the cables on the bridge lances.

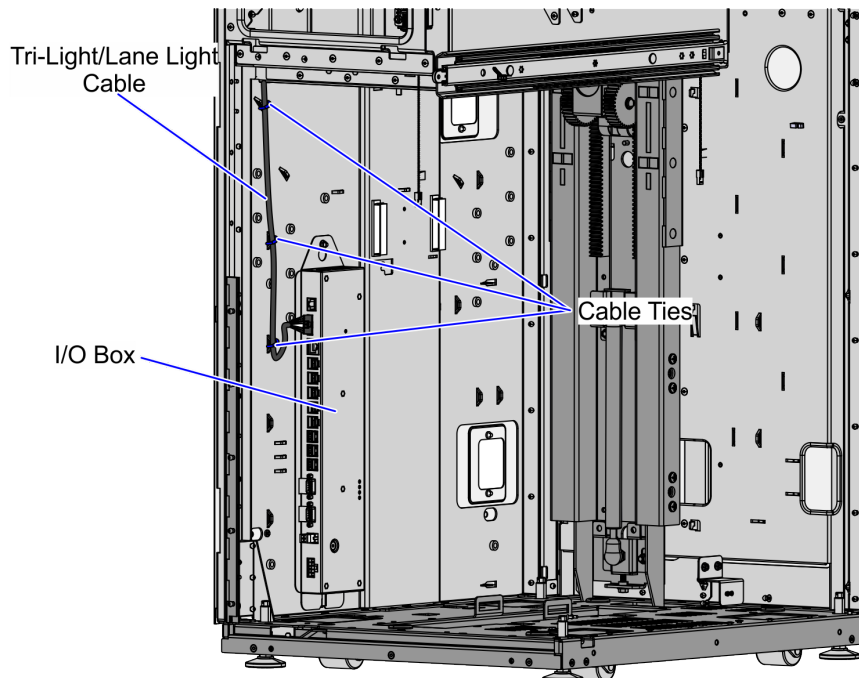

CCP-82469

- Connect the cable to the Tri-Light/Lane Light port of the I/O Box.

Confidential and proprietary information of NCR Voyix Corporation.
Unauthorized use, reproduction and/or distribution is strictly prohibited.

3. Route the LAN Cable. Depending on the unit configuration, refer to the following:
 - [Routing the LAN Cable: No-Bag on the next page](#)
 - [Routing the LAN Cable: Left-Hand Unit on page 29](#)
 - [Routing the LAN Cable: Right-Hand Unit on page 31](#)
4. Lower and raise the Tower Frame by rotating the Conversion Handle to ensure that the cables do not interfere with the movement.

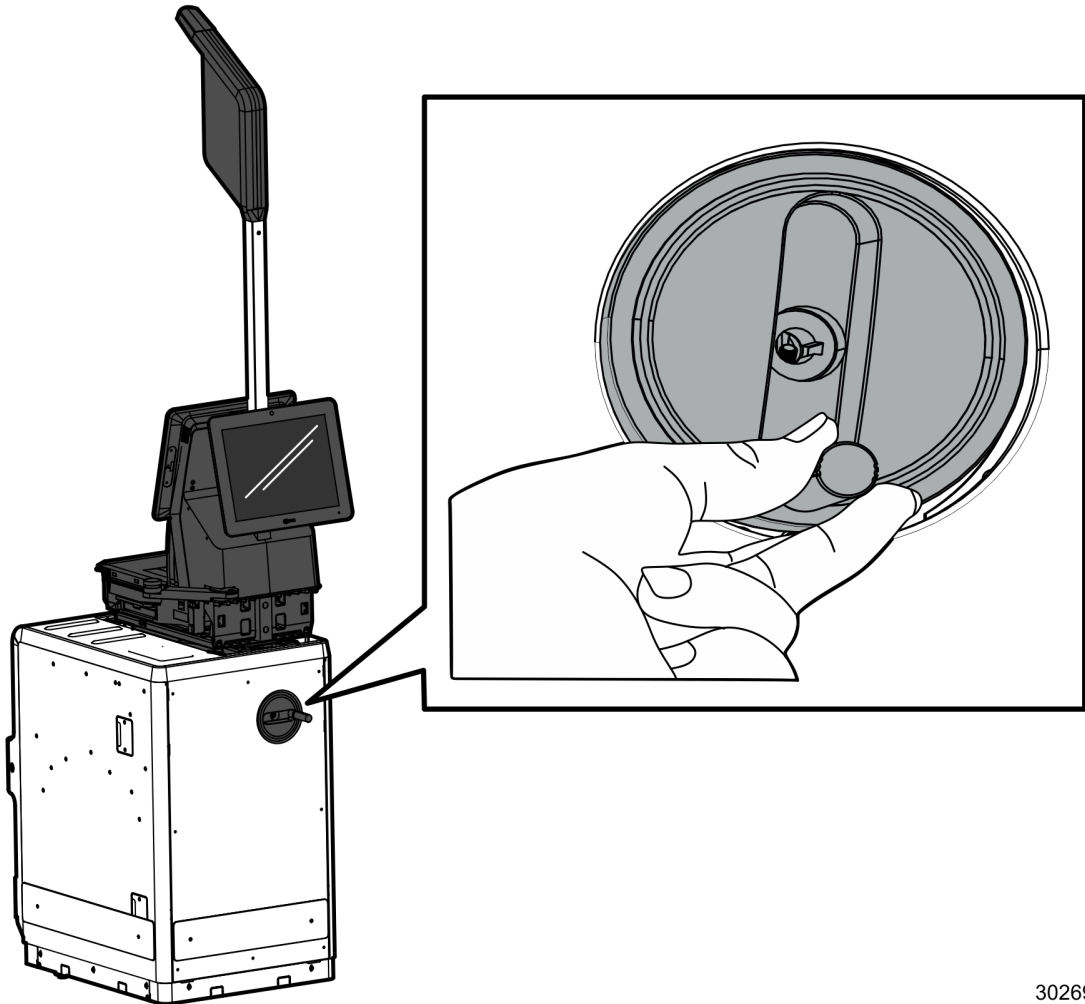

30269

Routing the LAN Cable: No-Bag

To route the LAN Cable, follow these steps:

1. From the corner cable access hole, route the cable down the Core Cabinet wall and down the bottom exit hole, as shown in the image below.

i Note
Pass the cable through cable clamps and secure the cable on the bridge lances using cable ties.

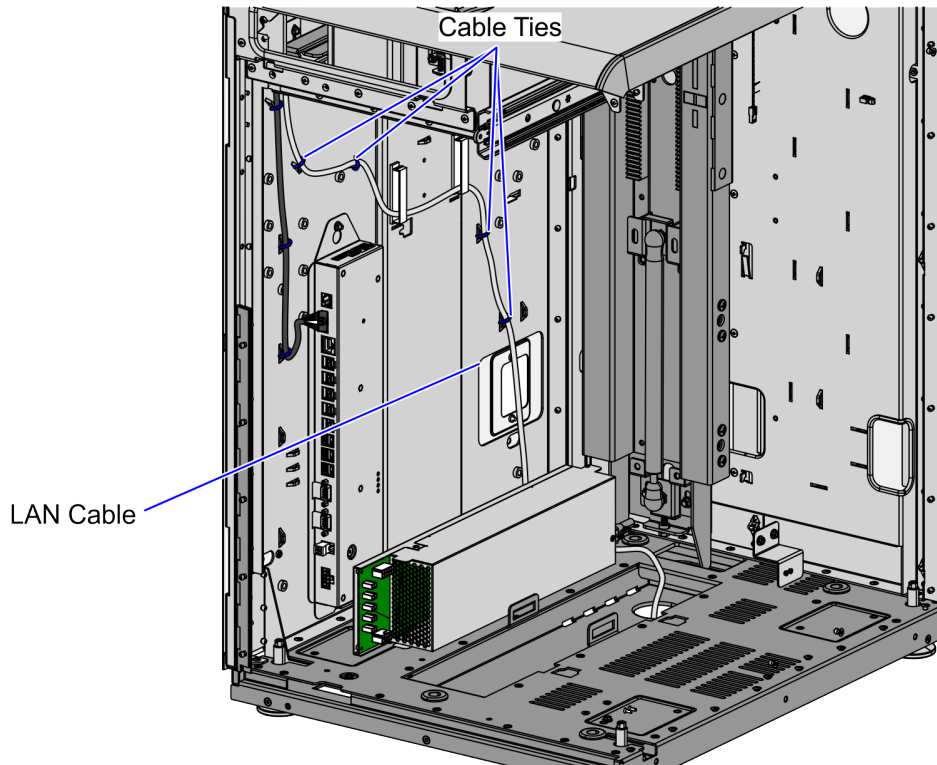

CCP-82494

2. Connect the cable to the PoE Switch.

Routing the LAN Cable: Left-Hand Unit

To route the LAN Cable, follow these steps:

1. From the corner cable access hole, route the cable down the Core Cabinet wall and through the cable access hole, as shown in the image below.

i Note

Pass the cable through cable clamps and secure the cable on the bridge lances using cable ties.

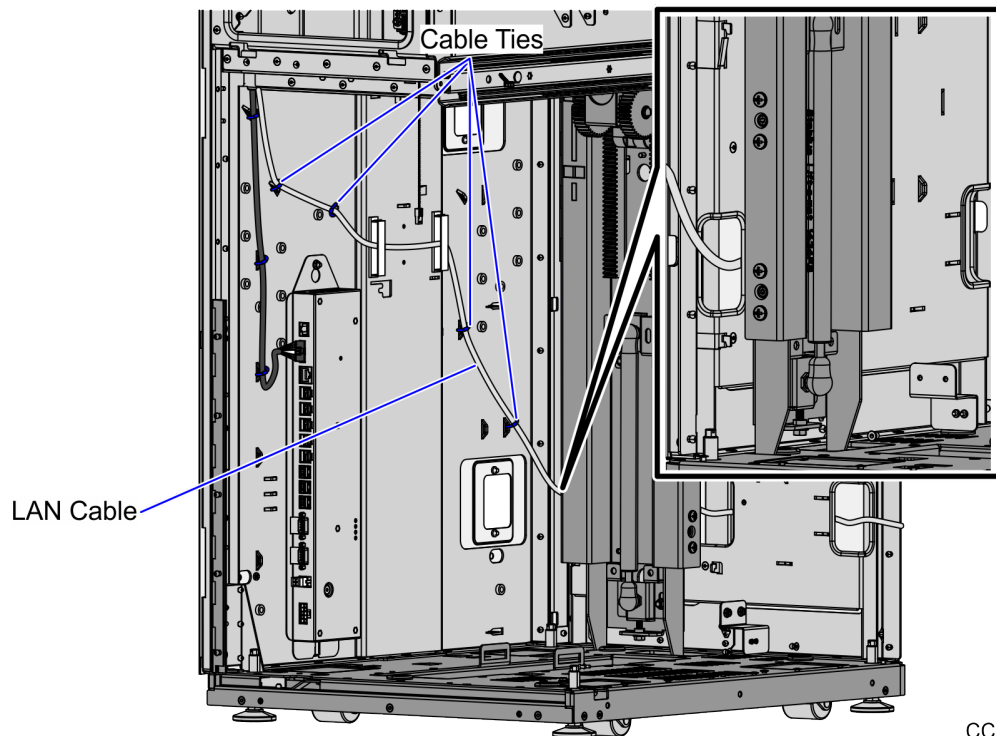

CCP-82470

2. Continue to route the cable into Bagwell through the left side exit hole and out through the bottom cable exit hole of the Bagwell.

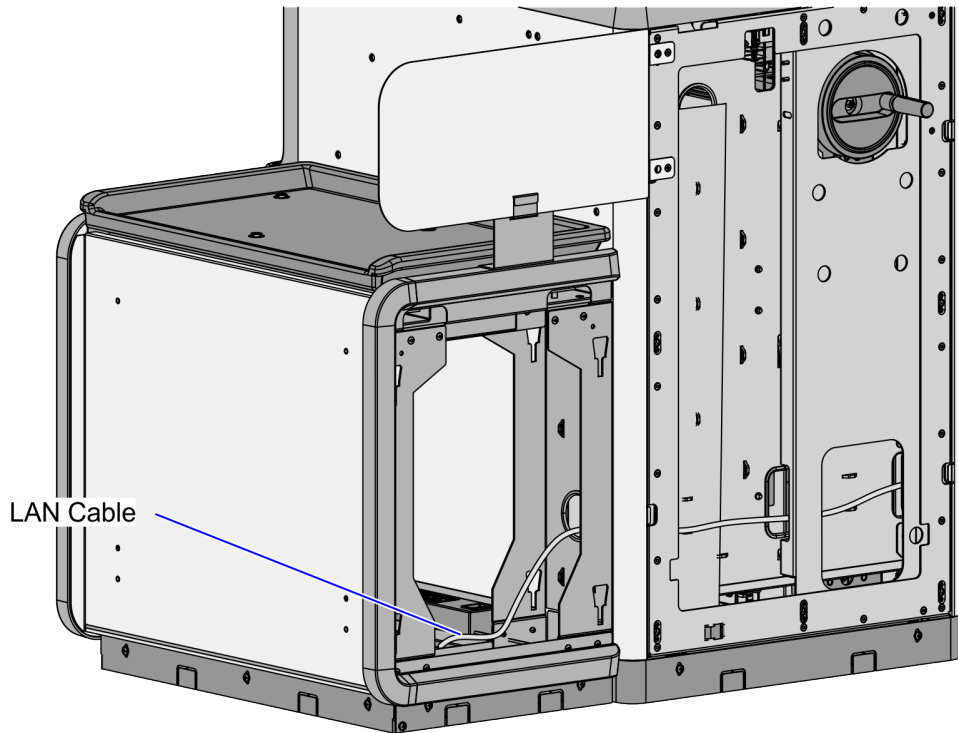

CCP-82468

3. Connect the cable to the PoE Switch.

Routing the LAN Cable: Right-Hand Unit

To route the LAN Cable, follow these steps:

1. From the corner cable access hole, route the cable down the Core Cabinet wall and through the right cable exit hole, as shown in the image below.

i Note

Pass the cable through cable clamps and secure the cable on the bridge lances using cable ties.

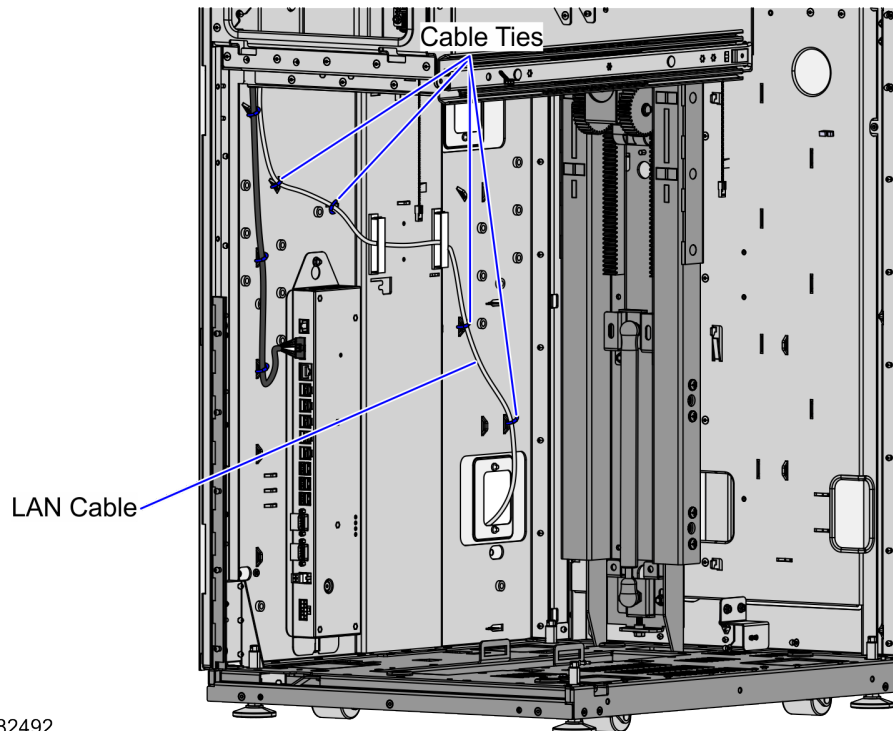

CCP-82492

2. Continue to route the cable to the Bagwell and out through the bottom cable exit hole.

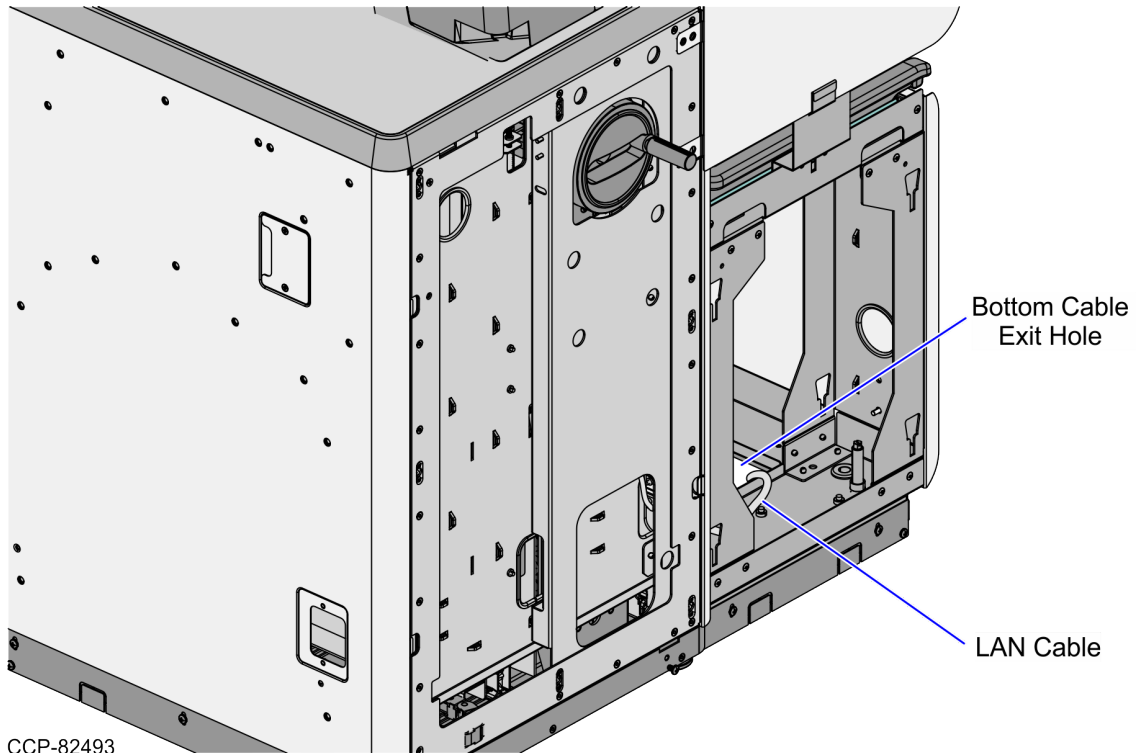

3. Connect the cable to the PoE Switch.

Routing the Cables: 7360 R6-C (Card Only)

To route the Tri-Light/Lane Light Cable and LAN Cable in the R6-C Card Only unit, follow these steps:

1. Do the following:
 - a. From the Tower Frame pole duct, route the Tri-Light/Lane Light Cable and the LAN Cable down through the built-in hooks inside the Tower Frame.
 - b. Route the cables down the Scanner Bucket floor. Use cable ties to secure the cable on the bridge lances.
 - c. Secure the cables to the anchor using a cable tie.

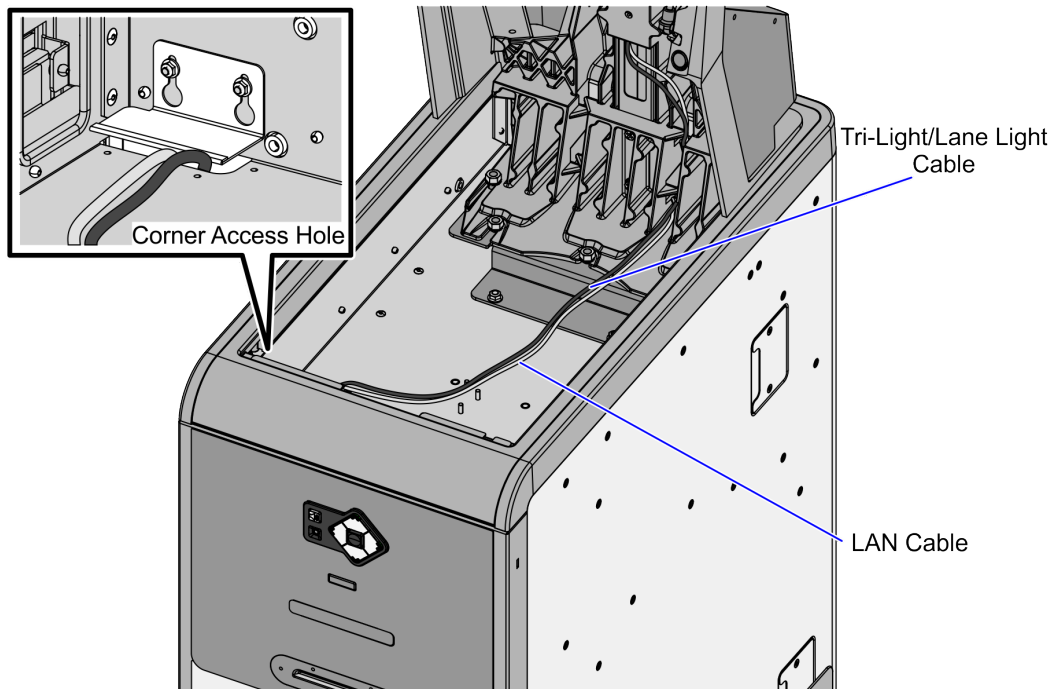

CCP-84174

2. Route the Tri-Light/Lane Light Cable by doing the following:
 - a. From the corner cable access hole, route the cable down the Core Cabinet wall and use cable ties to secure the cables on the bridge lances.
 - b. Connect the cable to the Tri-Light/Lane Light port of the I/O Box.

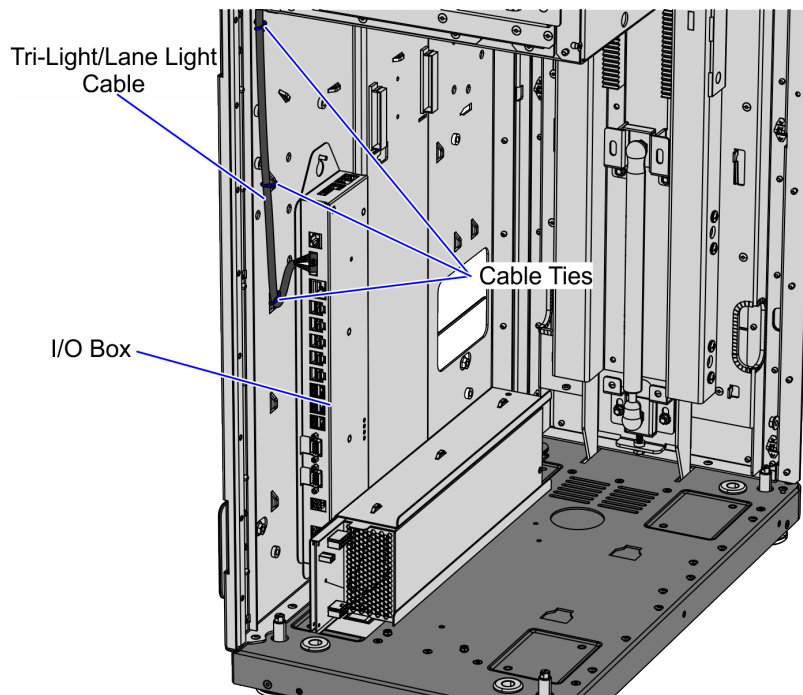

CCP-82463

3. Route the LAN Cable. Depending on the unit configuration, refer to the following:
 - [Routing the LAN Cable: No-Bag on the next page](#)
 - [Routing the LAN Cable: Left-Hand Unit on page 36](#)
 - [Routing the LAN Cable: Right-Hand Unit on page 38](#)

Routing the LAN Cable: No-Bag

To route the LAN Cable, follow these steps:

1. From the corner cable access hole, route the cable down the Core Cabinet wall and down the bottom exit hole, as shown in the image below.

i Note
Pass the cable through cable clamps and secure the cable on the bridge lances using cable ties.

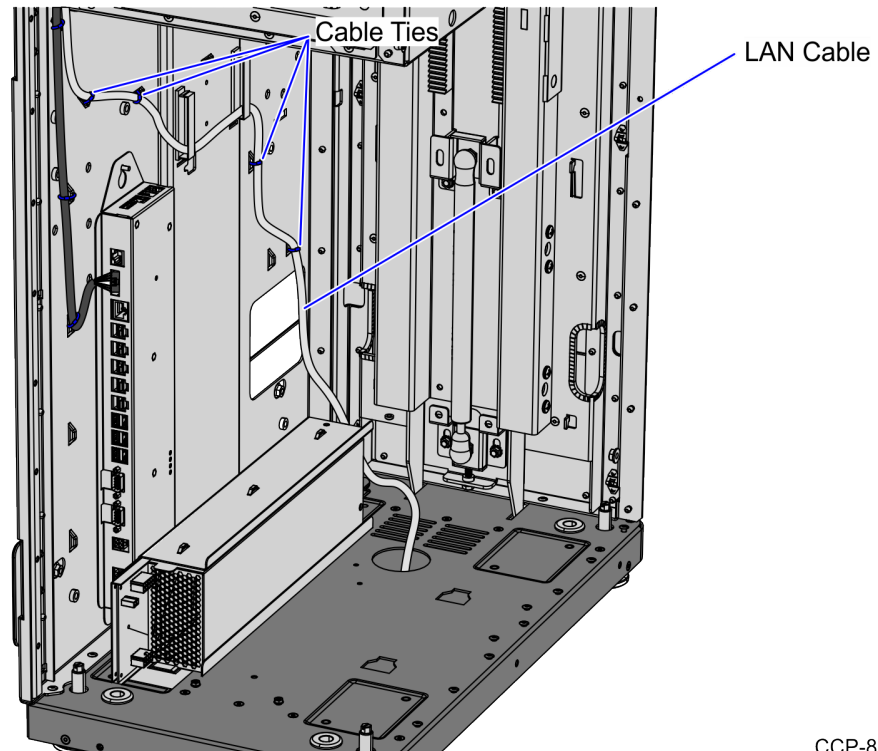

CCP-82489

2. Connect the cable to the PoE Switch.

Routing the LAN Cable: Left-Hand Unit

To route the LAN Cable, follow these steps:

1. From the corner cable access hole, route the cable down the Core Cabinet wall and through the cable access hole, as shown in the image below.

i Note

Pass the cable through cable clamps and secure the cable on the bridge lances using cable ties.

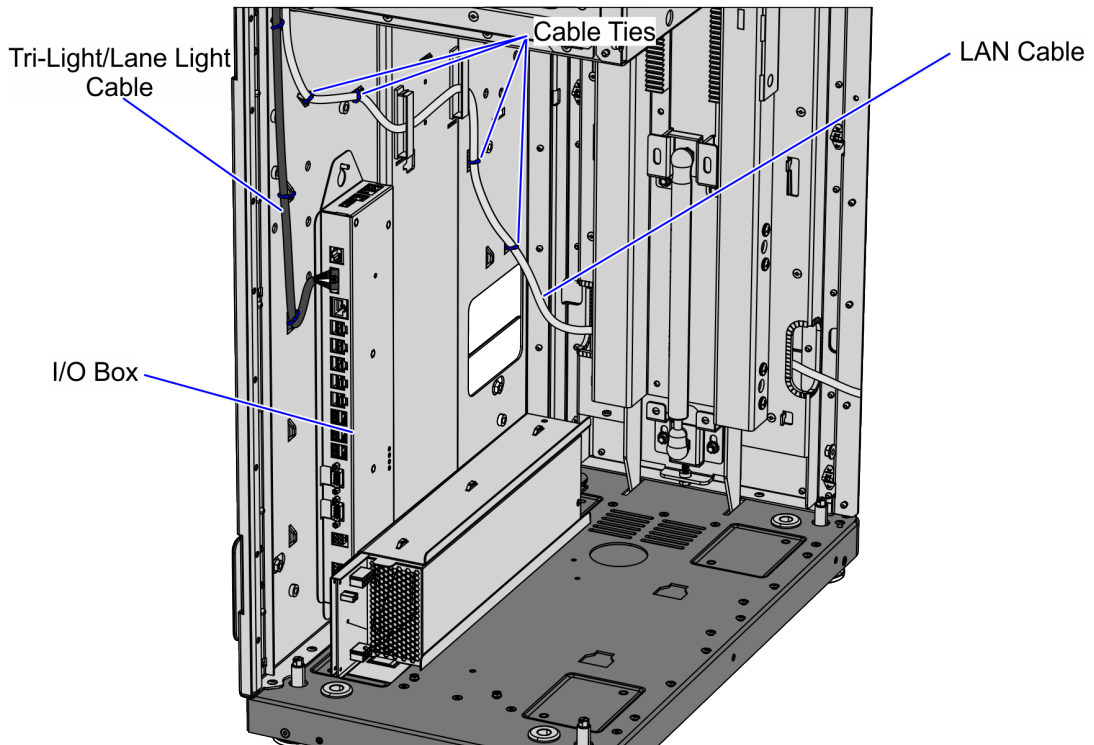

CCP-82453

2. Continue to route the cable into the Bagwell through the left side exit hole and out through the bottom cable exit hole of the Bagwell.

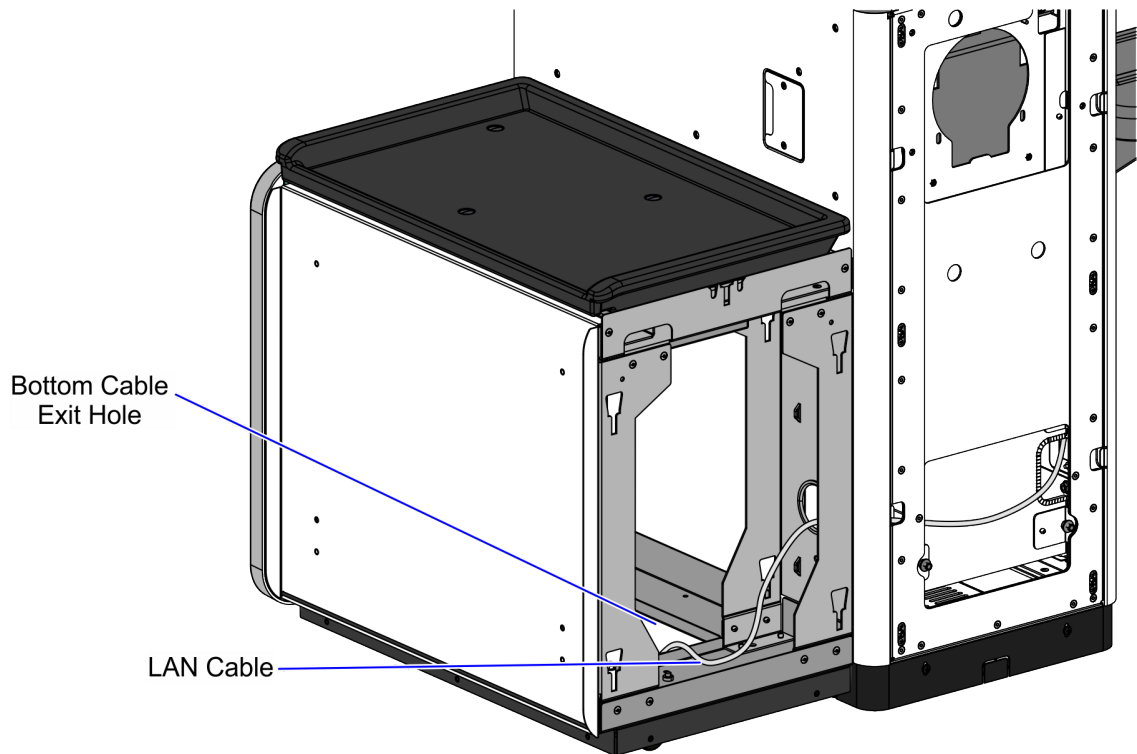

CCP-82461

3. Connect the LAN Cable to the PoE Switch.

Routing the LAN Cable: Right-Hand Unit

To route the LAN Cable, follow these steps:

1. From the corner cable access hole, route the cable down the Core Cabinet wall and through the right side exit hole, as shown in the image below.

i Note
Pass the cable through cable clamps and secure the cable on the bridge lances using cable ties.

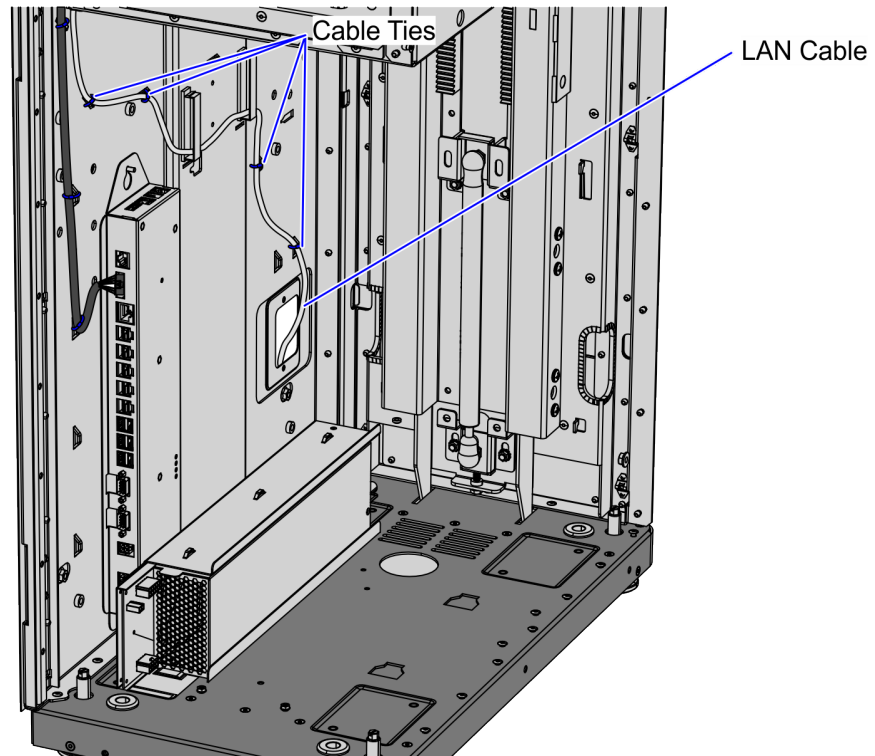

CCP-82490

2. Continue to route the cable to the Bagwell and out through the bottom cable exit hole.

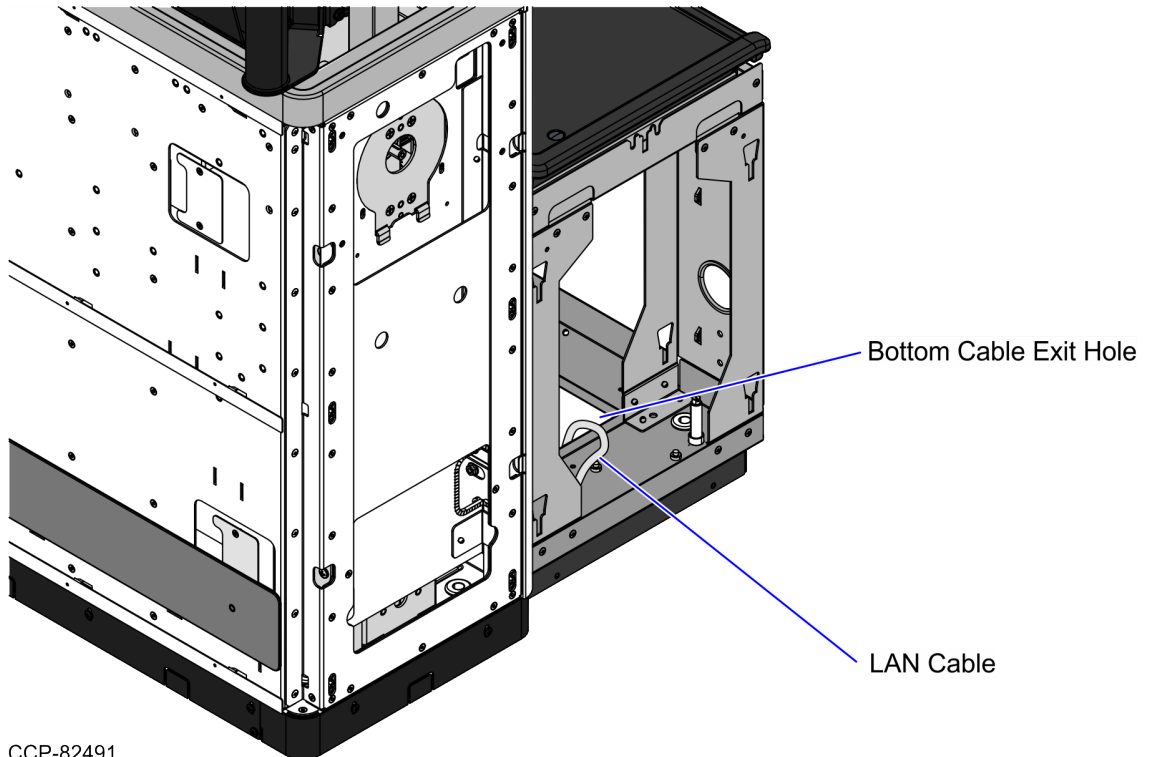

CCP-82491

3. Connect the cable to the PoE Switch.

Routing the Cables: 7357 R6LN Plus

To route the Tri-Light/Lane Light Cable and the LAN Cable in the 7357 unit, follow these steps:

1. Route the Tri-Light/Lane Light Cable by doing the following:
 - a. From the Tri-Light/Lane Light Pole, route the cable at the rear of the unit down the cable access hole and into the Core Cabinet, as shown in the image below. Use a cable tie to secure the cable to the vent.

i Note
Apply enough cable slack to prevent the cable from being stretched during installation or removal procedures.

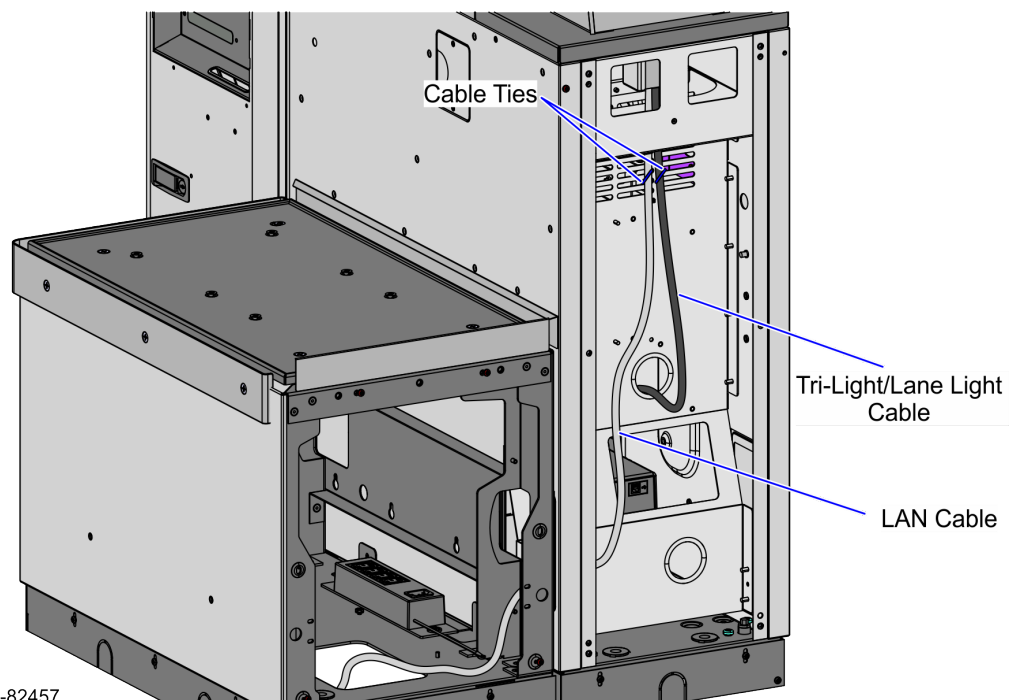

CCP-82457

- b. Connect the cable to the Tri-Light port of the I/O Box, as shown in the image below.
- c. Secure the cable to the lance bridges using cable ties.

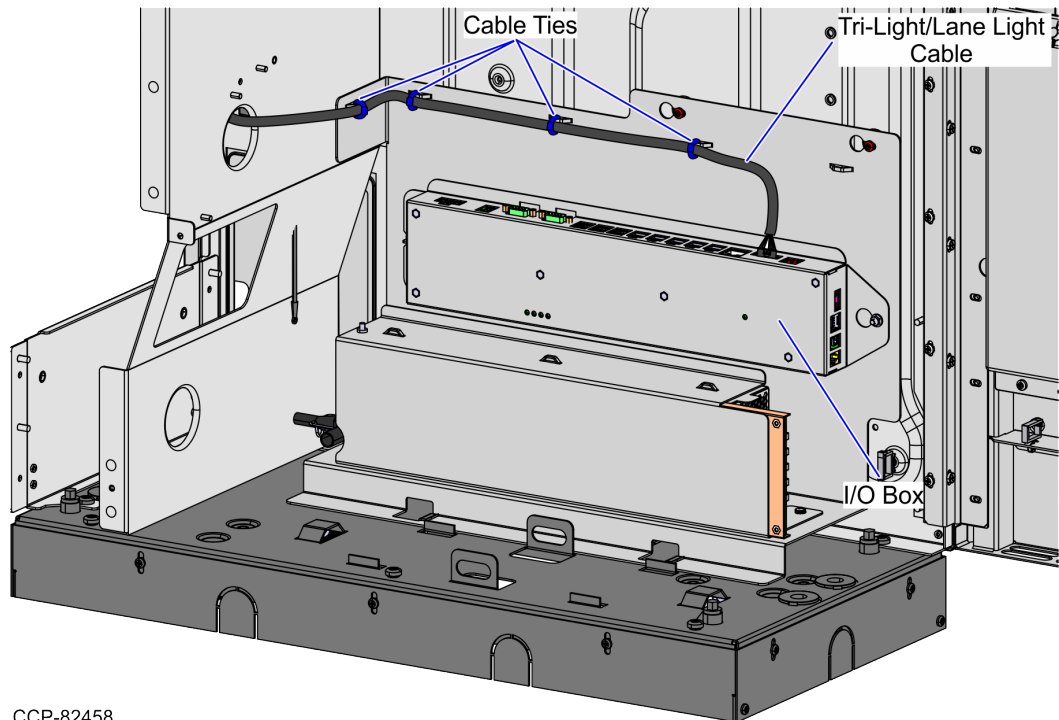

CCP-82458

2. Route the LAN Cable. Depending on the unit configuration, refer to the following:
 - [No-Bag Unit: 7357 R6LN Plus on the next page](#)
 - [Left-Hand Unit: 7357 R6LN Plus on page 44](#)
 - [Right-Hand Unit: 7357 R6LN Plus on page 45](#)

No-Bag Unit: 7357 R6LN Plus

To route the LAN Cable, follow these steps:

1. From the Tri-Light/Lane Light Pole, route the cable down the rear of the Core Cabinet and out through the side cable exit hole. Use a cable tie to secure the cable to the vent.

i Note
Ensure that there is enough cable slack to avoid cables from being stretched during installation or removal procedures.

i Note
The LAN Cable can exit either through the left or the right side cable exit hole depending on the customer's preference.

Left Side

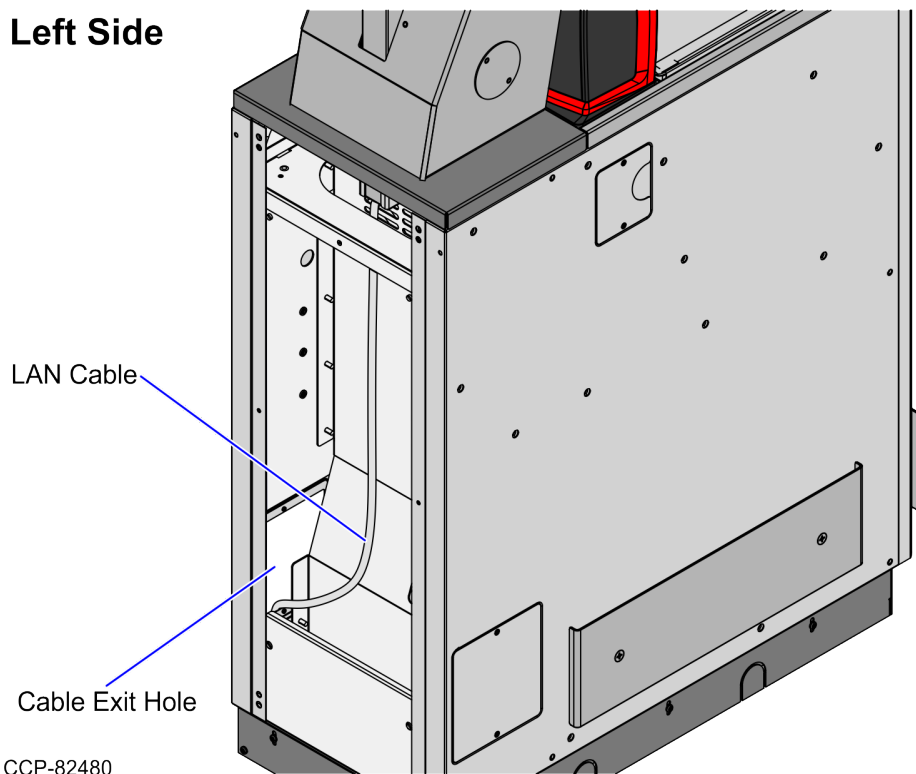

Right Side

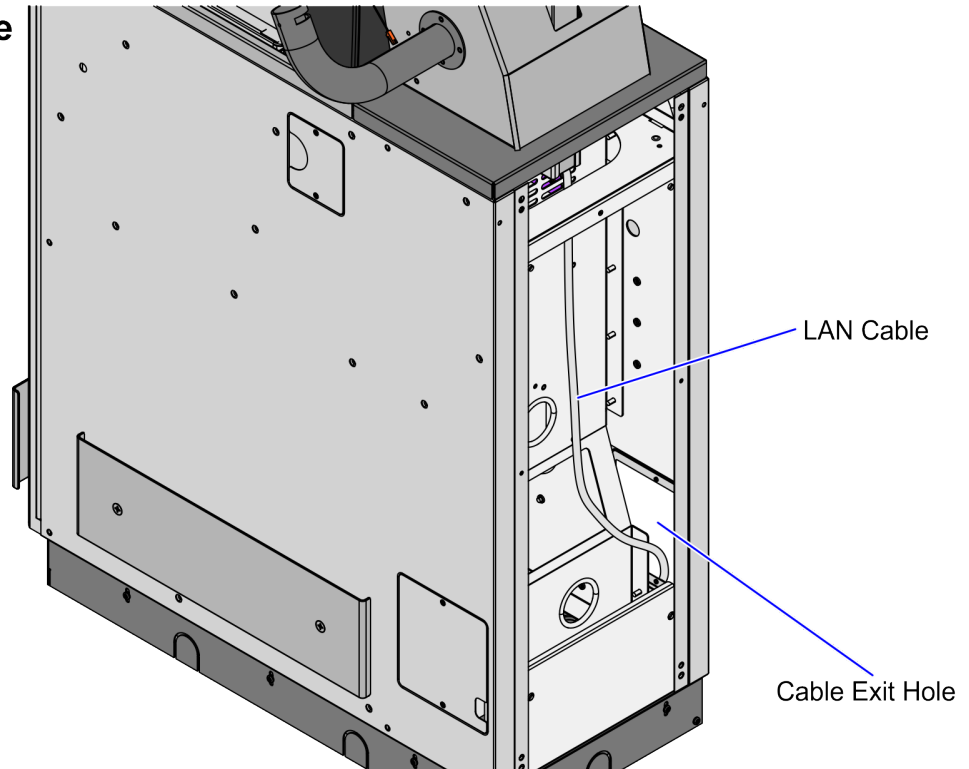

CCP-82481

2. Connect the cable to the PoE Switch.

Left-Hand Unit: 7357 R6LN Plus

To route the LAN Cable, follow these steps:

1. From the Tri-Light/Lane Light Pole, route the cable down the rear of the Core Cabinet. Use a cable tie to secure the cable to the vent.

i Note

Ensure that there is enough cable slack to avoid cables from being stretched during installation or removal procedures.

2. Continue to route the cable through the left side cable exit hole and into the Bagwell.
3. Pass the cable through the bottom cable exit hole of the Bagwell.

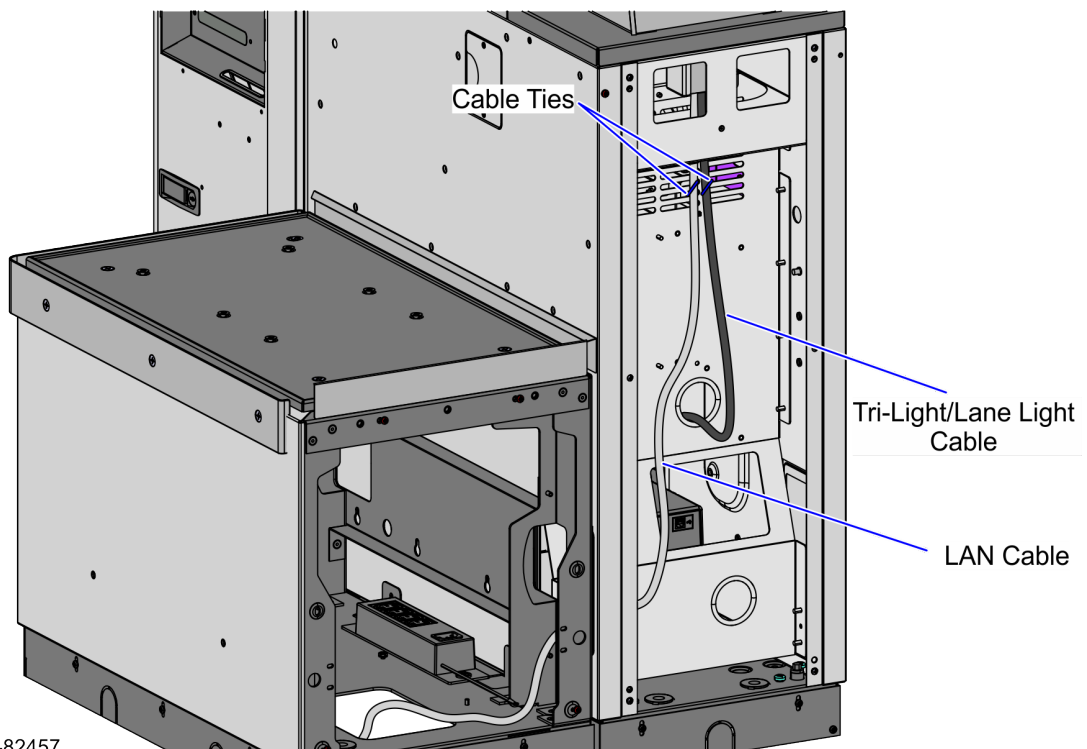

4. Connect the cable to the PoE Switch.

Right-Hand Unit: 7357 R6LN Plus

To route the LAN Cable, follow these steps:

1. From the Tri-Light/Lane Light Pole, route the cable down the rear of the Core Cabinet. Use a cable tie to secure the cable to the vent.

Note
Ensure that there is enough cable slack to avoid cables from being stretched during installation or removal procedures.

2. Continue to route the cable out through the right side cable exit hole and into the Bagwell.
3. Pass the cable through the bottom cable exit hole of the Bagwell.

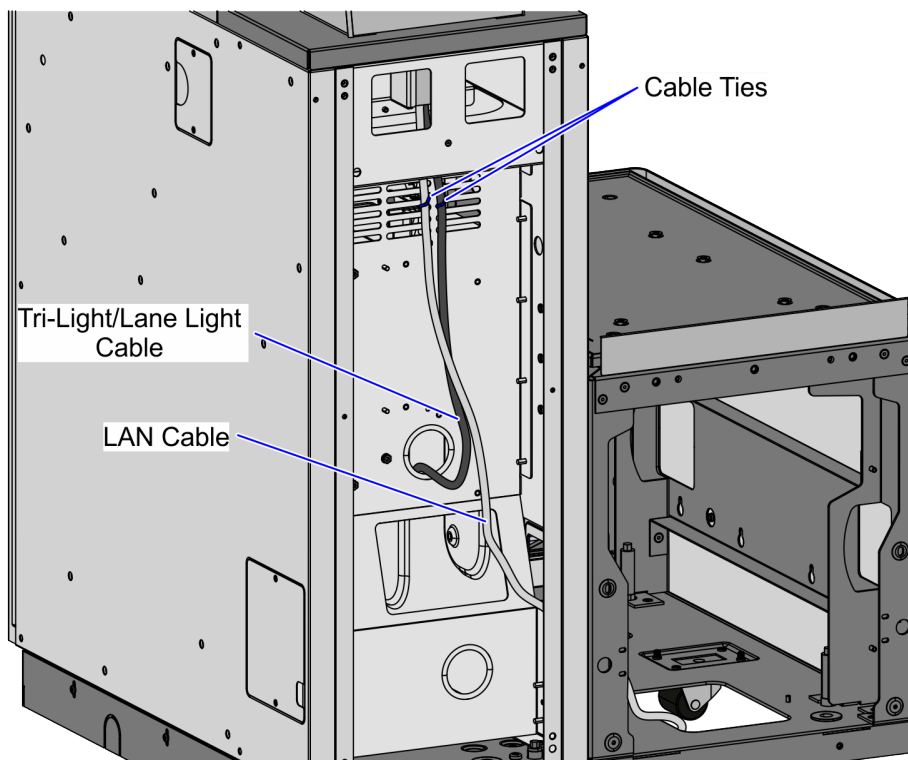

CCP-82483

4. Connect the cable to the PoE Switch.

Routing the Cables: 7358 R6L Plus

To route the Tri-Light/Lane Light Cable and the LAN Cable in the 7358 unit, follow these steps:

1. Route the Tri-Light/Lane Light Cable by doing the following:
 - a. From the Tri-Light/Lane Light Pole, route the cable up into the Upper Cabinet.

Note
Apply enough cable slack to prevent the cable from being stretched during installation or removal procedures.

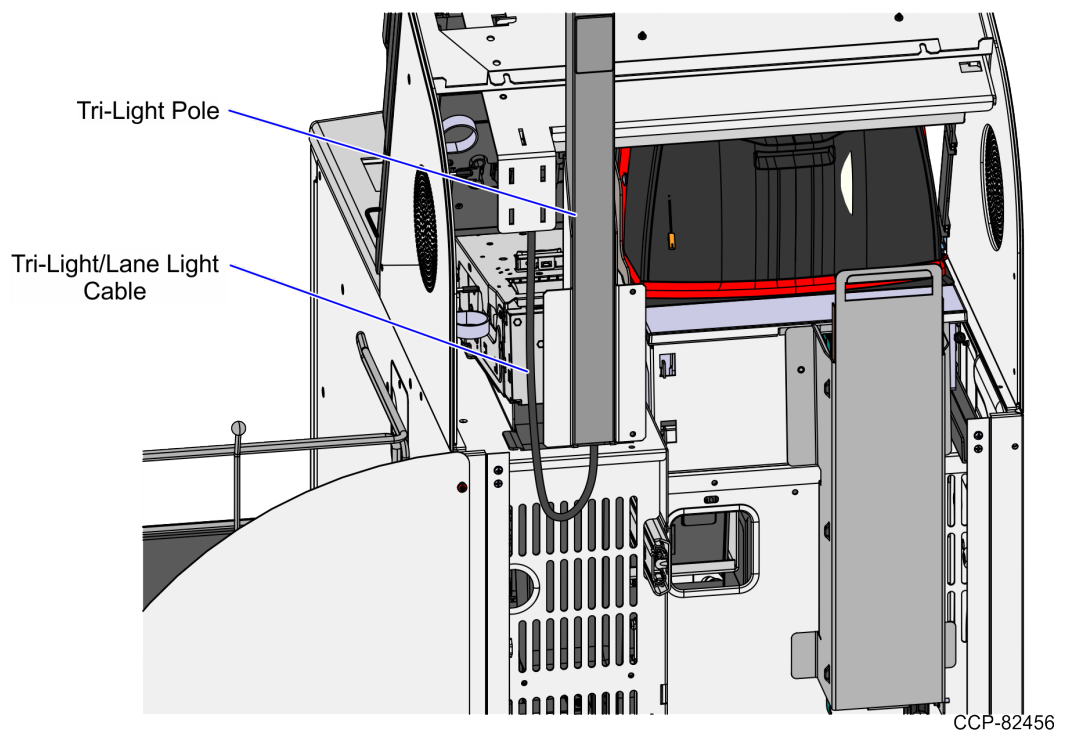

- b. Secure the cable to the Upper Cabinet frame using cable ties.

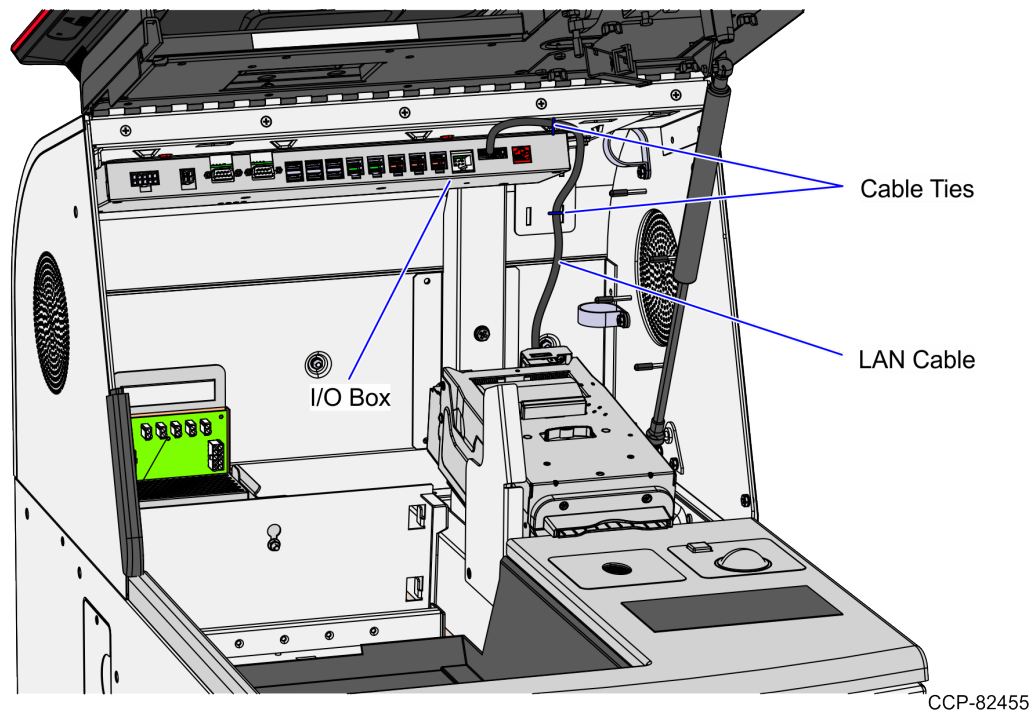

- c. Connect the cable to the Tri-Light/Lane Light port of the I/O Box.
- d. Route the LAN Cable. Depending on the unit configuration, refer to the following:
- [No-Bag Unit: 7358 R6L Plus on the next page](#)
 - [Left-Hand Unit: 7358 R6L Plus on page 50](#)
 - [Right-Hand Unit: 7358 R6L Plus on page 51](#)

No-Bag Unit: 7358 R6L Plus

To route the LAN Cable, follow these steps:

1. From the Tri-Light/Lane Light Pole, route the cable down the rear of the Core Cabinet and out through the side cable exit hole.

i Note

The LAN Cable can exit either through the left or the right side cable exit hole depending on the customer's preference.

Left Side

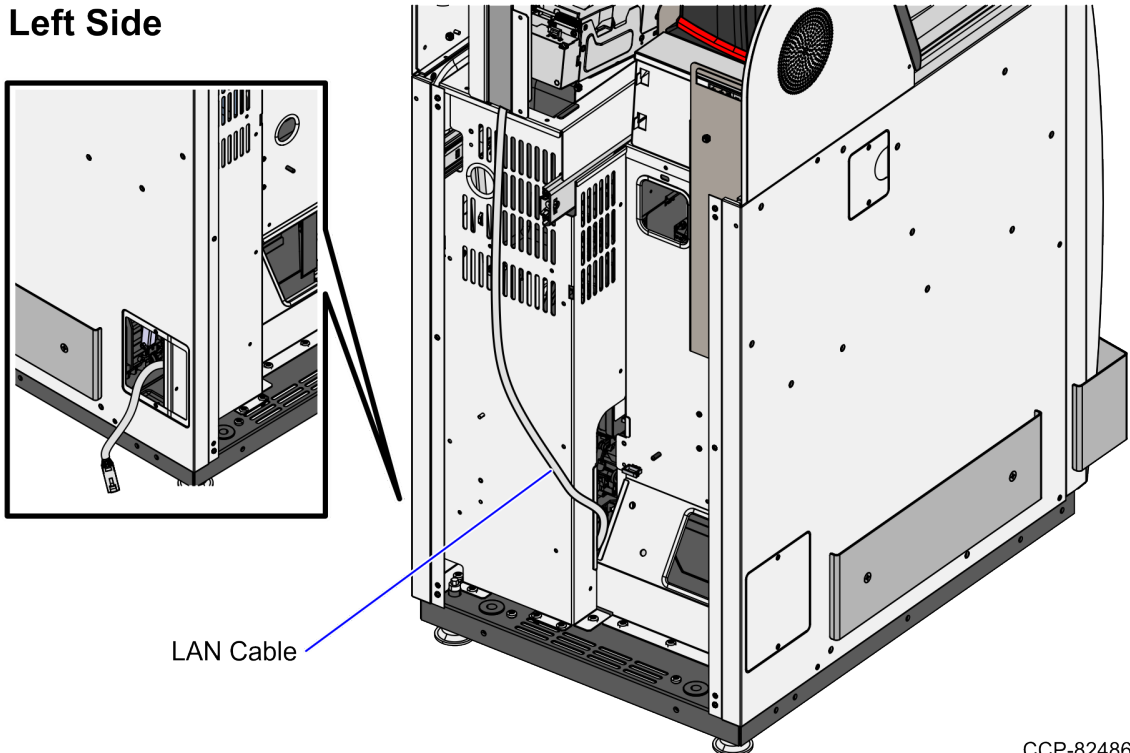

CCP-82486

Right Side

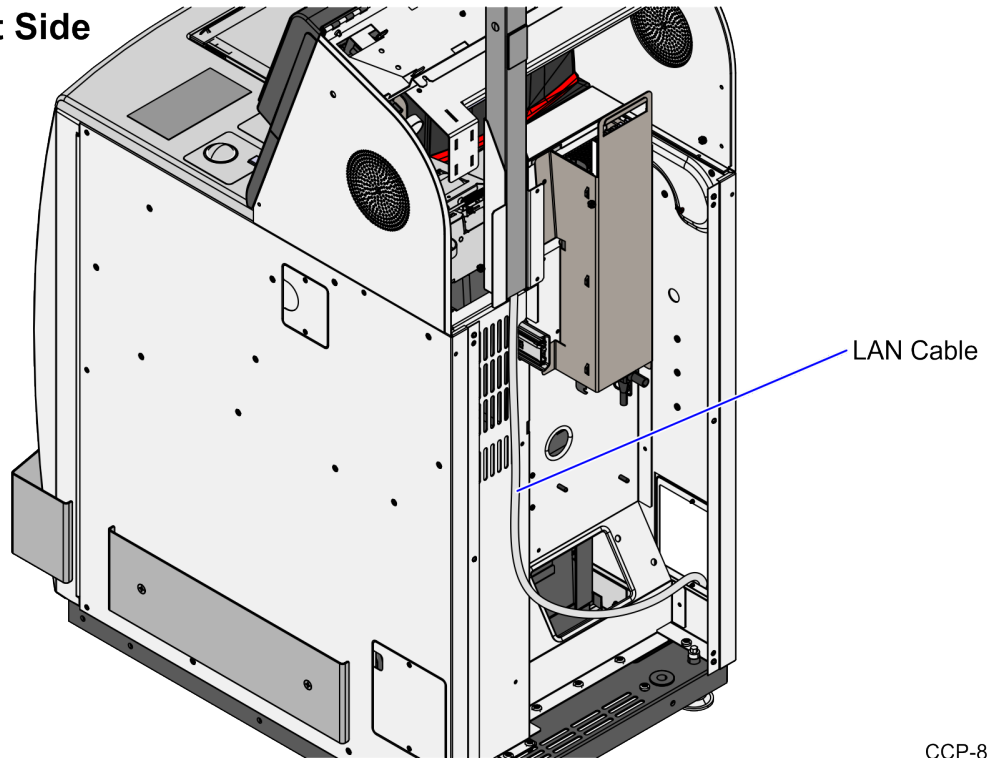

CCP-82485

2. Connect the cable to the PoE Switch.

Left-Hand Unit: 7358 R6L Plus

To route the LAN Cable, follow these steps:

1. From the Tri-Light/Lane Light Pole, route the cable down the rear of the Core Cabinet, through the side cable exit hole and into the Bagwell

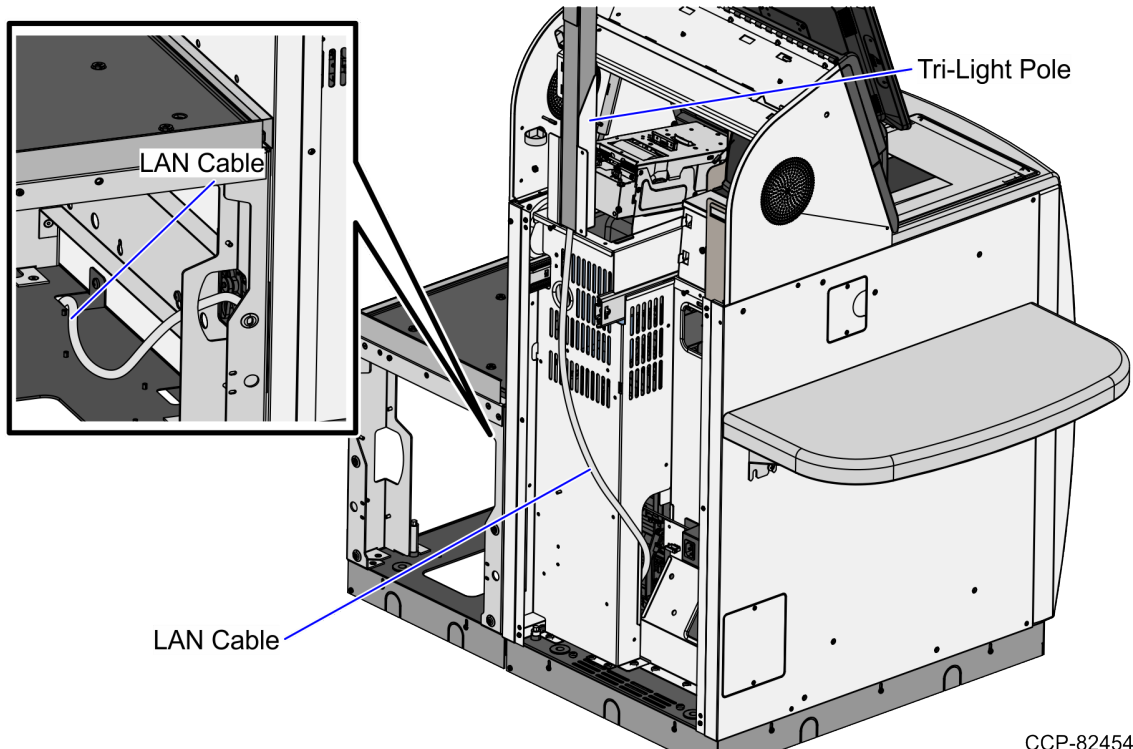

CCP-82454

2. Pass the cable through the bottom cable exit hole of the Bagwell.
3. Connect the cable to the PoE Switch.

Right-Hand Unit: 7358 R6L Plus

To route the LAN Cable, follow these steps:

1. From the Tri-Light/Lane Light Pole, route the cable down the rear of the Core Cabinet, through the side cable exit hole and into the Bagwell

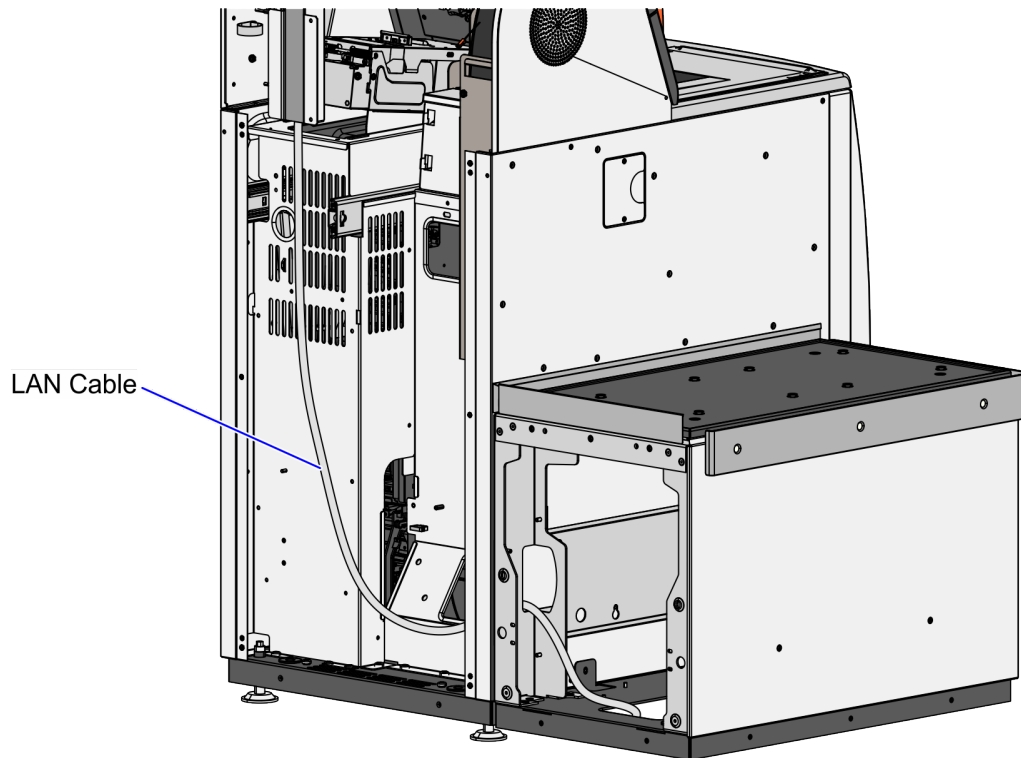

CCP-82484

2. Pass the cable through the bottom cable exit hole of the Bagwell.
3. Connect the cable to the PoE Switch.

Configuring the Camera Settings (VTC)

To configure the camera settings, follow these steps:

1. Connect the STP Ethernet Cable from the Tri-Light IP Camera Port to a POE Switch.
2. Connect another LAN Cable from the host to same POE Switch.
3. Access the camera view by doing the following:
 - a. If viewing the IP Camera for the first time, set the security of the Internet Explorer browser first and then install the Activex file, as shown in the image below.

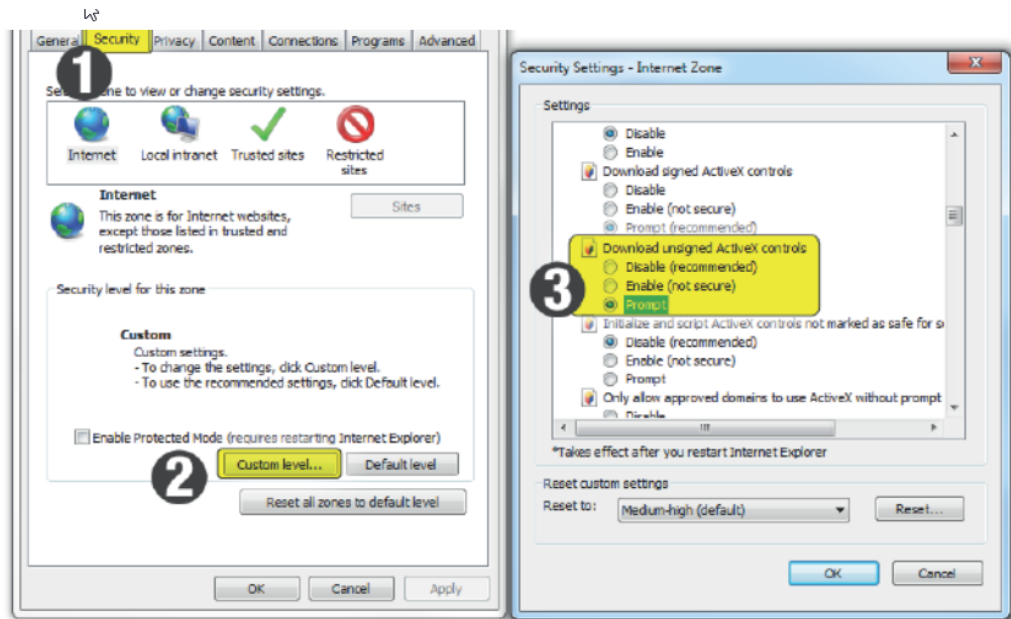

- b. Enter the IP Address of the network camera in the address bar and press **Enter** to access the login interface. The default IP address is 192.168.1.168.

Note
The host PC must have the same network ID with the camera device.

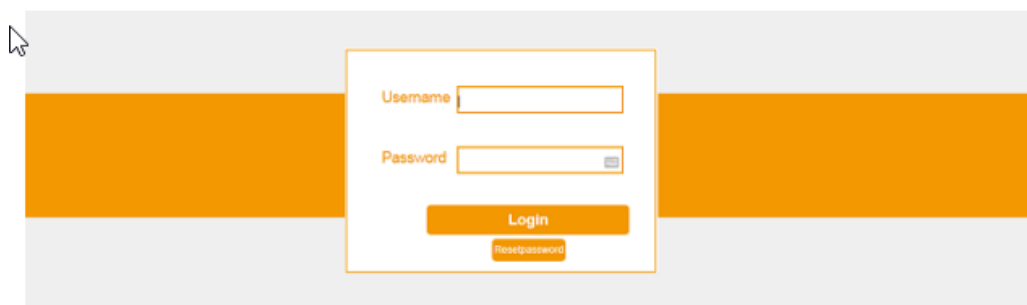

c. Enter the following default login credentials:

Username: **admin**

Password: **123456**

A download link to the plugin is displayed on the Camera View user interface, as shown in the image below.

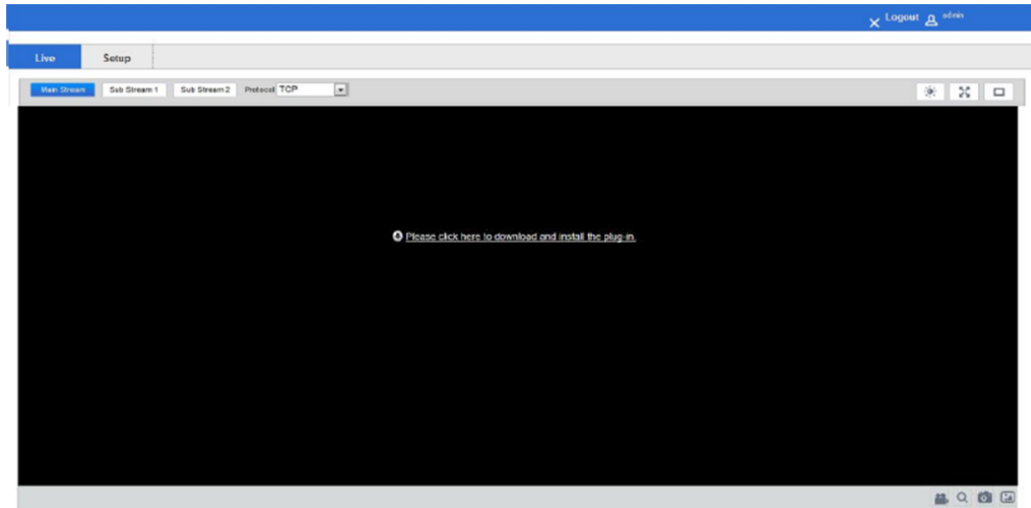

4. Click the link to download the plug-in. The browser opens a live feed of the camera, as shown in the image below.

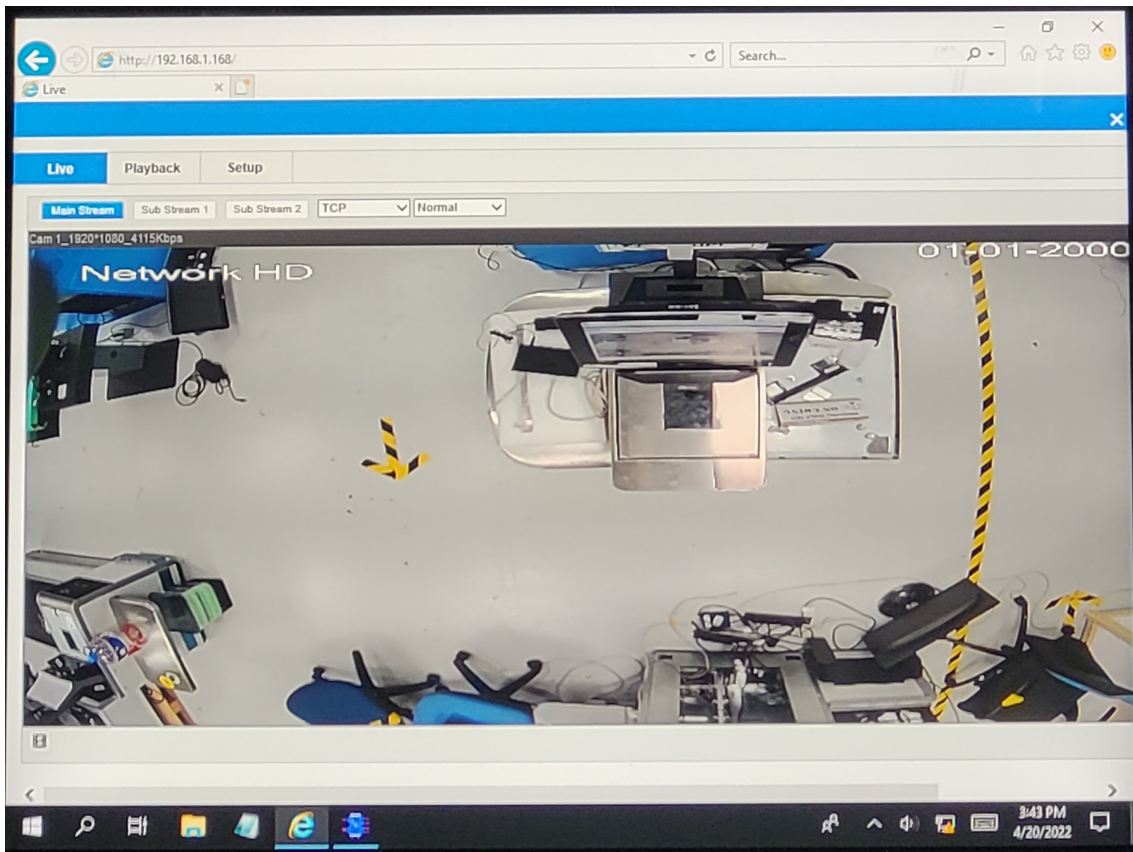

Confidential and proprietary information of NCR Voyix Corporation.
Unauthorized use, reproduction and/or distribution is strictly prohibited.

5. Adjust the view of the camera to ensure that the following conditions are met:
 - Customer's normal reach to Input and Bagwell areas are visible.
 - Customer area is visible.
 - Cart area is visible.

i Note

The image below shows an example of an ideal camera view. For the purpose of illustration only, the image below shows a Left-hand (LH) unit. For more information on setting the camera parameters, refer to [VTC Network Camera User Manual](#).

Fixed and Convertible

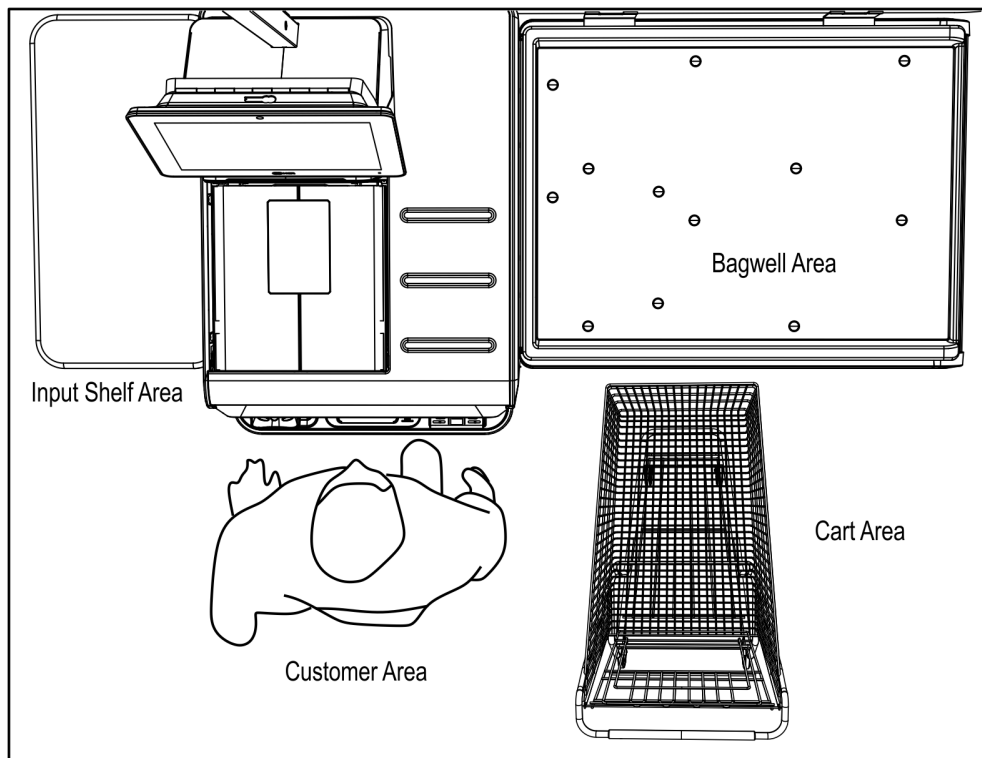

CCP-76737

Confidential and proprietary information of NCR Voyix Corporation.
Unauthorized use, reproduction and/or distribution is strictly prohibited.

Card Only

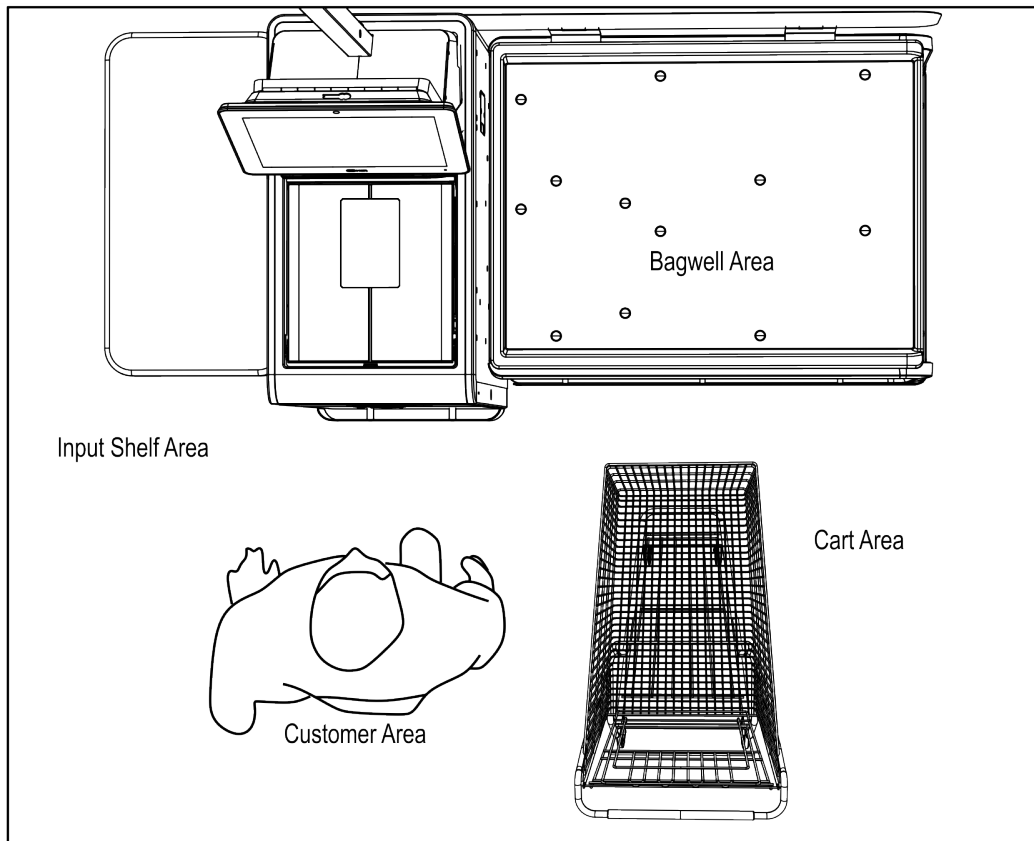

CCP-83452

7357 R6LN Plus

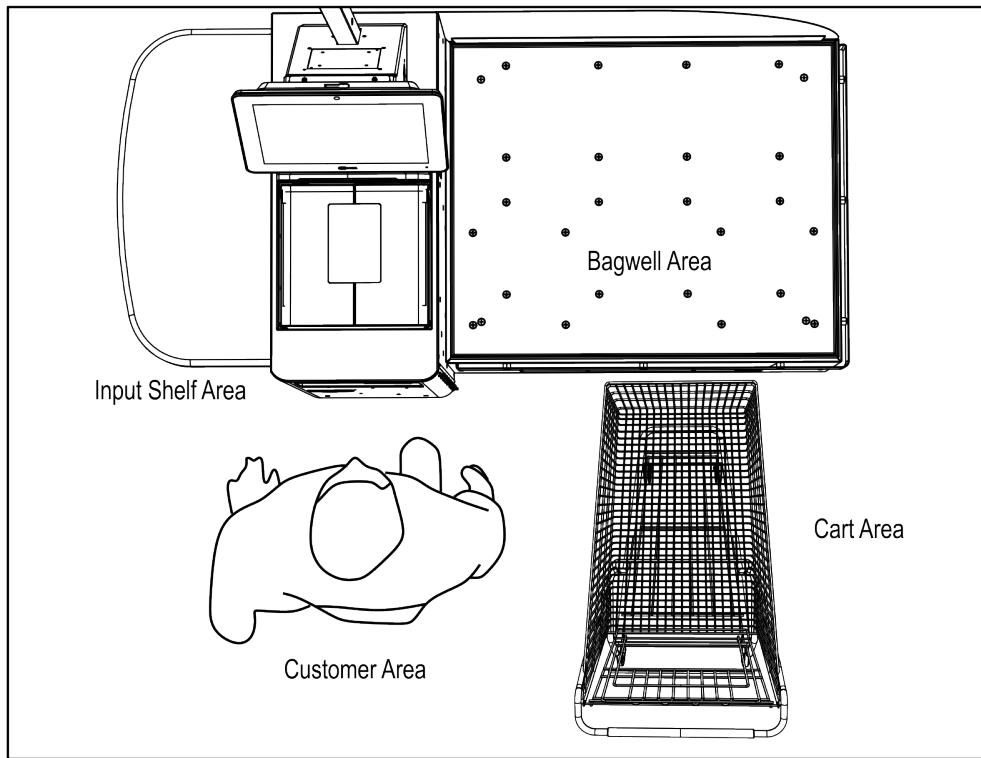

CCP-83479

Confidential and proprietary information of NCR Voyix Corporation.
Unauthorized use, reproduction and/or distribution is strictly prohibited.

7358 R6L Plus

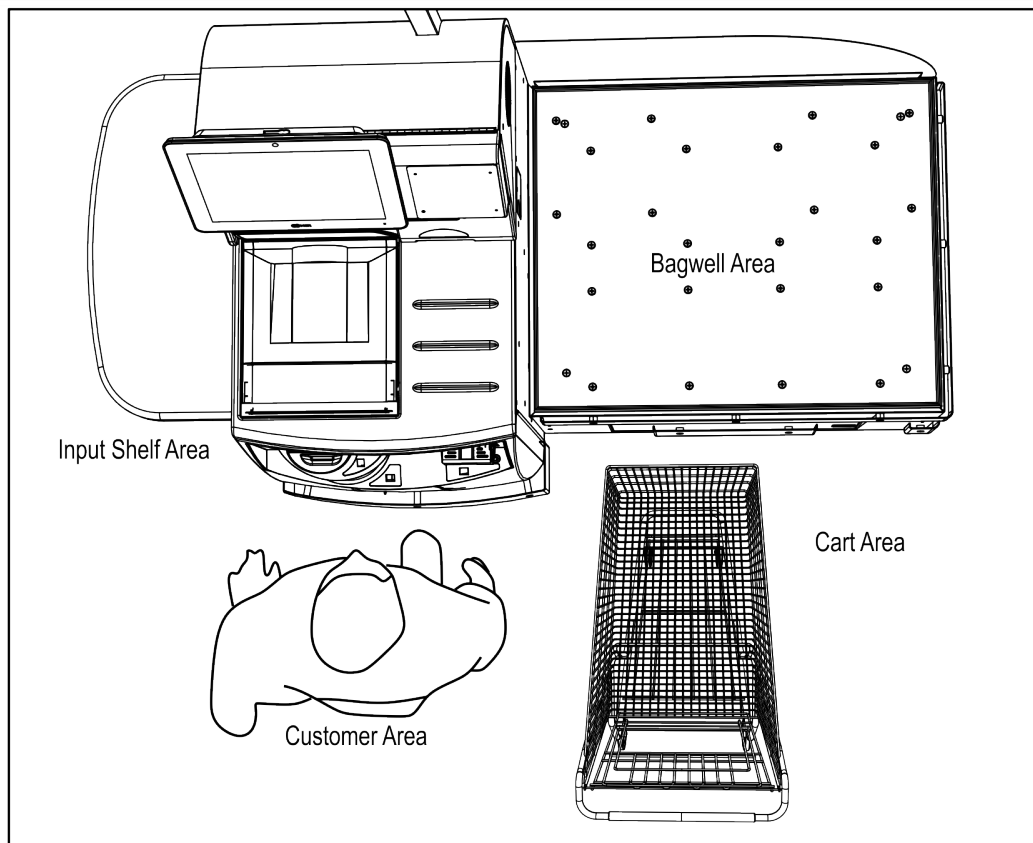

CCP-83480

i Note
Ensure that the NCR Customer Helpdesk is informed when the Tri-Light/Lane Light with IP Camera is installed in the store.

i Note
For additional camera configuration, refer to [VTC Network Camera User Manual](#).