

Kit Instructions

Non-Scale 2-Bag Bagwell Upgrade

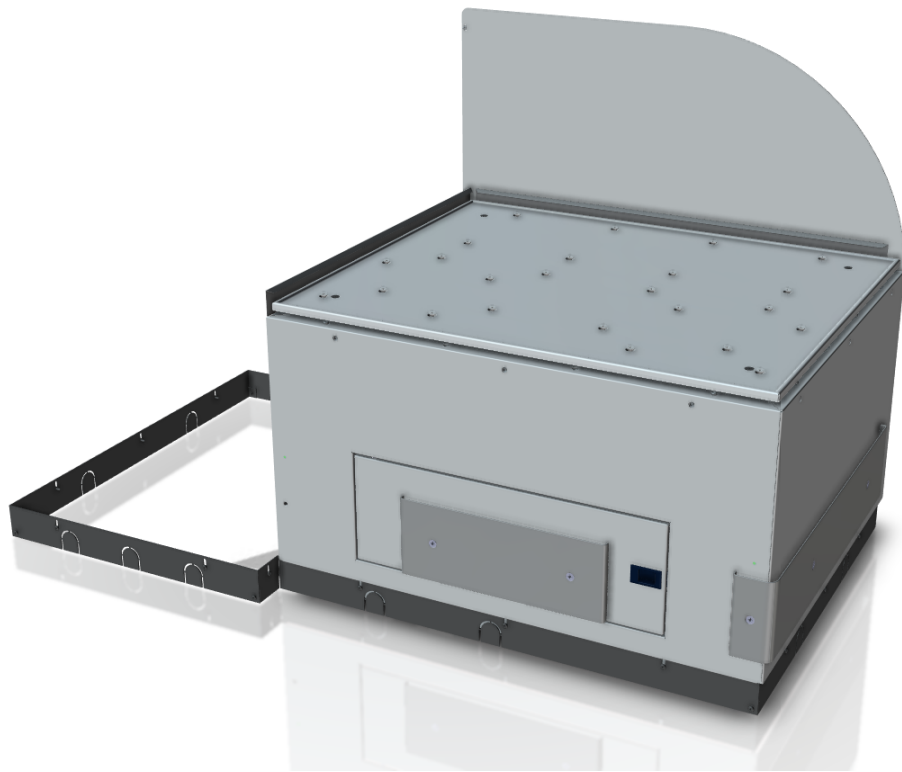

7358-K122/K145
Issue B



The product described in this document is a licensed product of NCR Corporation.

NCR is a registered trademark of NCR Corporation. NCR FastLane SelfServ™ Checkout is a trademark of NCR Corporation in the United States and/or other countries. Other product names mentioned in this publication may be trademarks or registered trademarks of their respective companies and are hereby acknowledged.

The terms HDMI and HDMI High-Definition Multimedia Interface, and the HDMI Logo are trademarks or registered trademarks of HDMI Licensing LLC in the United States and other countries.

Where creation of derivative works, modifications or copies of this NCR copyrighted documentation is permitted under the terms and conditions of an agreement you have with NCR, NCR's copyright notice must be included.

It is the policy of NCR Corporation (NCR) to improve products as new technology, components, software, and firmware become available. NCR, therefore, reserves the right to change specifications without prior notice.

All features, functions, and operations described herein may not be marketed by NCR in all parts of the world. In some instances, photographs are of equipment prototypes. Therefore, before using this document, consult with your NCR representative or NCR office for information that is applicable and current.

Copyright © 2021
By NCR Corporation
Global Headquarters
864 Spring St. NW
Atlanta, GA 30308
United States
All Rights Reserved

Revision Record

Issue	Date	Remarks
A	Jul 2020	First Issue
B	Nov 2021	Updated Kit Contents

Non-Scale 2-Bag Bagwell Upgrade

This publication provides procedures for upgrading an NCR FastLane SelfServ™ Checkout (7358), either a from No-Bag unit or a unit with an existing Bagwell, to a unit with a Non-Scale 2-Bag Bagwell.

The NCR FastLane SelfServ™ Checkout with a Bagging Area (Bagwell) Module or Large Basket (Large Basket) Module can be configured for either Left-hand (LH) orientation or Right-hand (RH) orientation, which refers to the direction customers scan and bag items.

- **Left-hand (LH) orientation**—Customers scan from left to right.
- **Right-hand (RH) orientation**—Customers scan from right to left.



Note: The orientation of the unit is determined by the position of the Lower Core (Cabinet) Module in relation to the Bagwell or Large Basket.

Example: The Left-hand (LH) unit has the Cabinet positioned on the left side of the Bagwell or Large Basket.

Kit Contents

Depending on the color variant of the Non-Scale Bagwell, refer to the following sections for information about kit contents:

- [7358-K122 Non-Scale 2-Bag Bagwell Upgrade \(Walmart Medium Gray\)](#) on the facing page.
- [7358-K145 Non-Scale 2-Bag Bagwell Upgrade \(Walmart Light Blue\)](#) on page 6.



Note: The 7358-K122 and 7358-K145 Kits include Core skirt panels that customers may use to replace their existing Core skirt panels.

7358-K122 Non-Scale 2-Bag Bagwell Upgrade (Walmart Medium Gray)

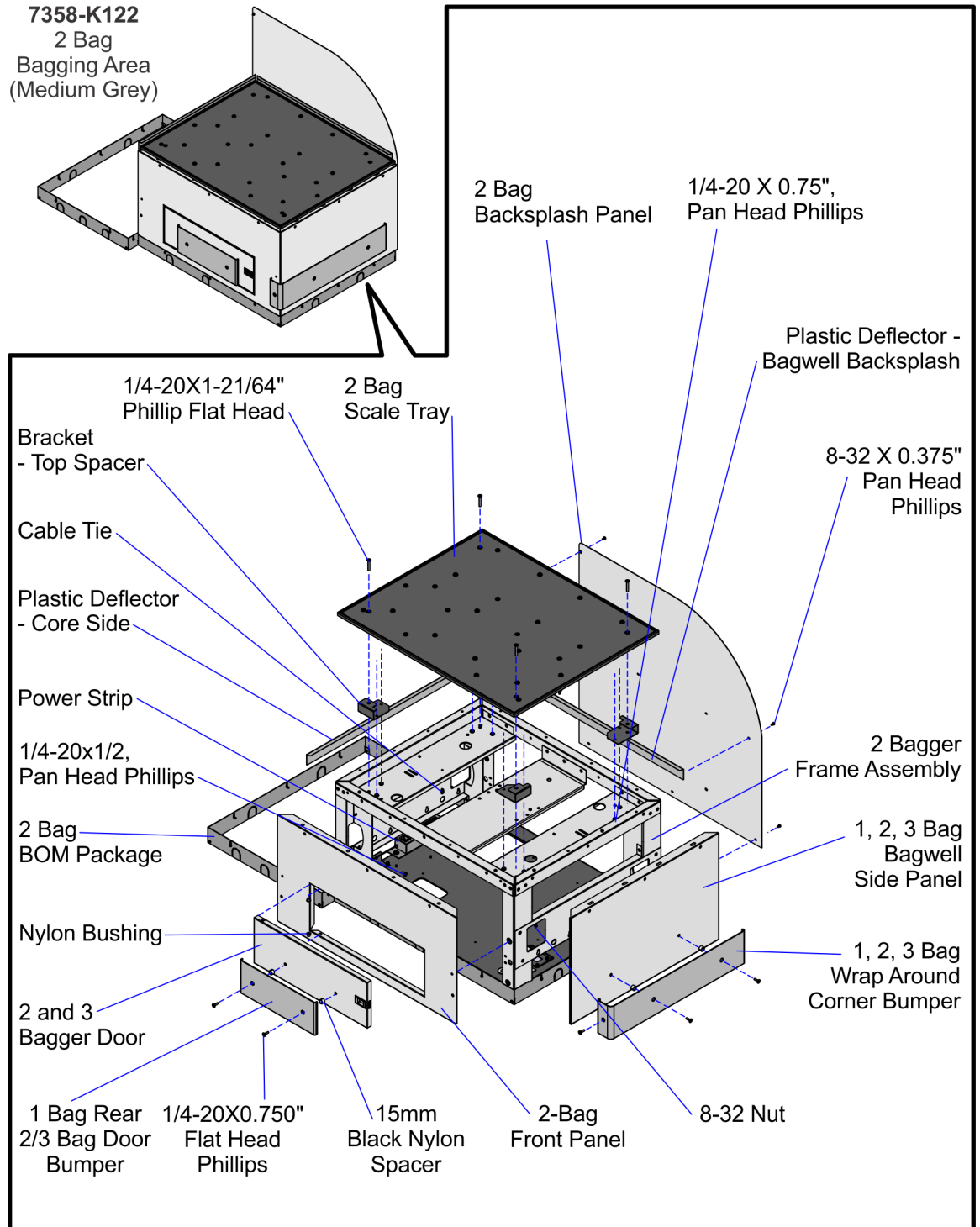

Part Number	Description
497-0527862	7358-K122 Kit, 2-Bag Bagwell Module, Non-Scale with Lower Bagwell Bumpers (Walmart Medium Gray)
795-0283628	Assembly - 2 and 3-Bag Door (Walmart Medium Gray)
795-0134228	Panel - 2-Bag Backsplash (Walmart Medium Gray)
795-0134128	Panel - 2-Bag Front (Walmart Medium Gray)
795-0133328	Panel - 1/2/3 Bagwell Side (Walmart Medium Gray)
* 795-0281628	Hole Cover Label - (Light Royal Gray)
006-8604541	Screw, ¼-20 x ½, Pan Head, Phillips (4 pcs)
497-0528668	Assembly - 2-Bag Frame with Leveling Feet and Casters
497-0526950	Skirt - 2-Bag BOM Package
497-0472268	2-Bag Scale Tray with Bag Rack Hardware
006-8611143	Nut Keps, 8-32, Steel, Blue Zinc (5 pcs)
006-8611505	Bushing, Nylon (2 pcs)
497-0455519	Plastic Deflector - Core Side
497-0455521	Plastic Deflector - Bagwell Backsplash - 2-Bag
009-0005930	Cable Tie-Snap In Mounting (3 pcs)
006-8612446	Screw - 8-32 x 0.375 in Phil Pan, Self Tapping - Type F (14 pcs)
006-8616060	Screw - ¼-20 x 0.75 in, Pan Head, Phillips, Zinc Plated Steel (8 pcs)
006-8623998	Screw - ¼-20 x 1-21/64 in, Phillips Flat Head, 82 Degree, Machine Thread, Zinc-Plated Steel (4 pcs)
497-0421485	Power Strip, IEC 4-POS, Plastic Case
497-0426042	Bag - 2 and 3.5 Bagger, LHC and RHC, Input Belt
007-9714414	Tie Strap Plain 5.60 LG (2 pcs)
* 497-0513382	Label - Multiple Power Sources/ Disconnect Power Caution
497-0521432	Bracket - Top - Spacer (4 pcs)
497-0518277	Bumper - 1, 2, 3-Bag Side, Wrap Around Corner

Part Number	Description
006-8612492	Screw - ¼-20 x 0.750 in, Phillips Flat Head, 82 Degree, Machine Thread, Zinc-Plated Steel (5 pcs)
497-0457054	Black Nylon Spacer 15 mm OD x 10.4 mm ID x 10 mm L (5 pcs)
497-0518274	Bumper - 1 Bag Rear, 2/3 Bag Door
* 497-0423108	Instructions-Kit (Reference Sheet)

* Items marked with an asterisk are not called out on the image.

7358-K145 Non-Scale 2-Bag Bagwell Upgrade (Walmart Light Blue)

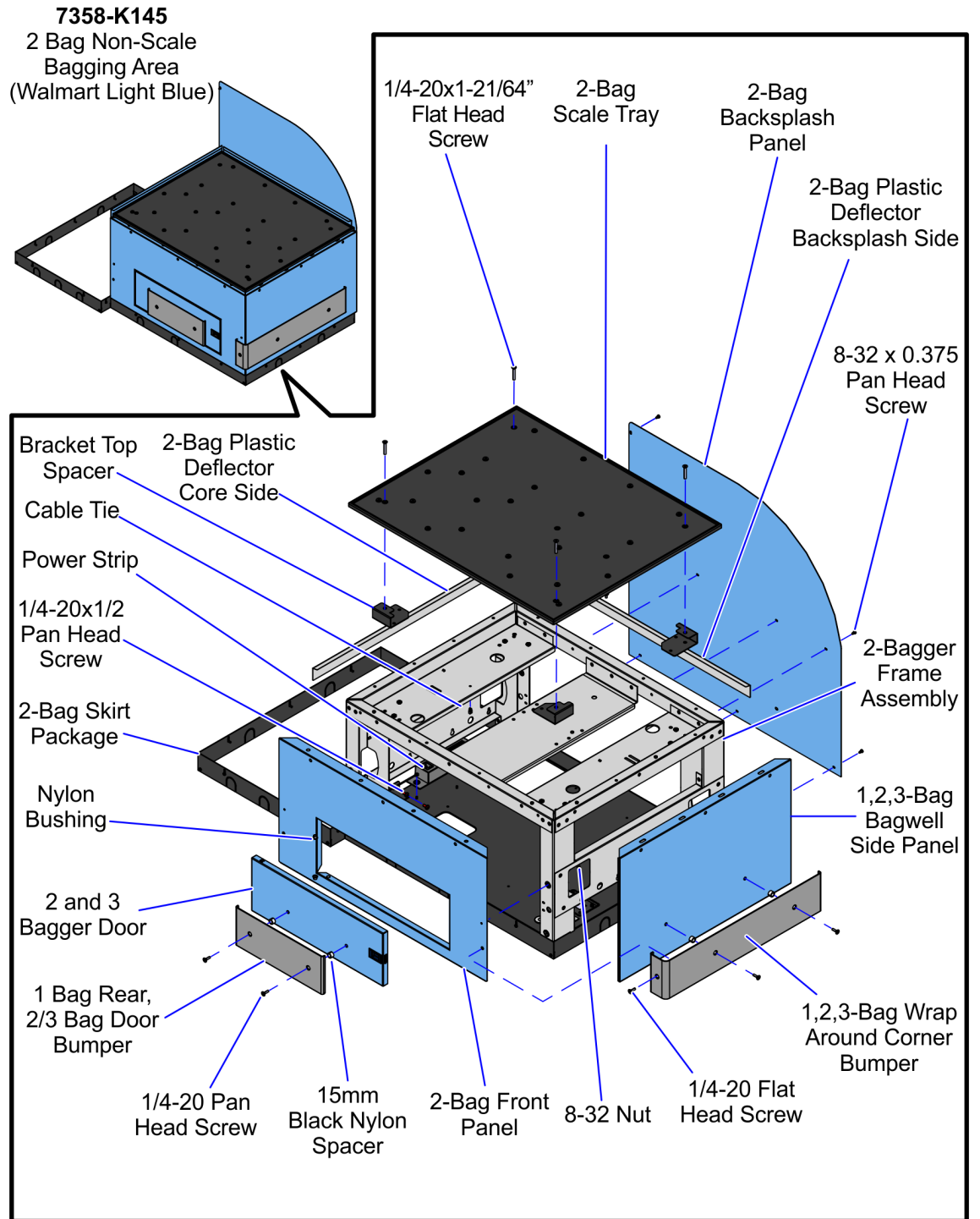

Part Number	Description
497-0528439	7358-K145 Kit, 2-Bag Bagwell Module, Non-Scale with Lower Bagwell Bumpers (Walmart Light Blue)
795-0283612	Assembly - 2 and 3-Bag Door (Walmart Light Blue)
795-0134212	Panel - 2-Bag Backsplash (Walmart Light Blue)
795-0134112	Panel - 2-Bag Front (Walmart Light Blue)
795-0133312	Panel - 1/2/3 Bagwell Side (Walmart Light Blue)
795-0281612	Hole Cover Label - (Walmart Light Blue)
006-8604541	Screw, ¼-20 x ½, Pan Head, Phillips (4 pcs)
497-0525620	Assembly - 2-Bag Frame with Leveling Feet And Casters
497-0526950	Skirt - 2-Bag BOM Package
497-0472268	2-Bag Scale Tray with Bag Rack Hardware
006-8611143	Nut Keps, 8-32, Steel, Blue Zinc (5 pcs)
006-8611505	Bushing, Nylon (2 pcs)
497-0455519	Plastic Deflector - Core Side
497-0455521	Plastic Deflector - Bagwell Backsplash - 2-Bag
009-0005930	Cable Tie - Snap In Mounting (3 pcs)
006-8612446	Screw - 8-32 x 0.375 in Phil Pan, Self Tapping - Type F (14 pcs)
006-8616060	Screw - ¼-20 x 0.75 in, Pan Head, Phillips, Zinc Plated Steel (8 pcs)
006-8623998	Screw - ¼-20 x 1-21/64 in, Phillips Flat Head, 82 Degree, Machine Thread, Zinc-Plated Steel (4 pcs)
497-0421485	Power Strip, IEC 4-POS, Plastic Case
497-0426042	Bag - 2 and 3.5 Bagger, LHC and RHC, Input Belt
007-9714414	Tie Strap Plain 5.60 Lg (2 pcs)
497-0513382	Label - Multiple Power Sources/ Disconnect Power Caution
497-0521432	Bracket - Top - Spacer (4 pcs)
497-0457054	Black Nylon Spacer 15 mm OD x 10.4 mm ID x 10 mm L (5 pcs)
497-0518277	Bumper - 1, 2, 3-Bag Side, Wrap Around Corner
497-0518274	Bumper - 3-Bag Rear, 2/3 Bag Door

Part Number	Description
006-8612492	Screw - ¼-20 x 0.750 in, Phillips Flat Head, 82 Degree, Machine Thread, Zinc- Plated Steel (5 pcs)
* 497-0423108	Instructions Kit (Reference Sheet)

* Items marked with an asterisk are not called out on the image.

Installation Procedures

Installing the Bagwell upgrade involves the following procedures:

- [Installing Core Skirt Panels](#) on the next page.



Note: This procedure may be optional.

- [Removing Existing Non-Scale Bagwell](#) on page 12.
- [Changing Bagwell Orientation](#) on page 18.



Note: This procedure may be optional.

- [Installing New Non-Scale Bagwell](#) on page 22.
- [Installing Bagwell Skirt Panels](#) on page 28.
- [Routing Cables](#) on page 30.

Installing Core Skirt Panels

To install the Core skirt panels, follow these steps:



Note: The 7358-K122 and 7358-K145 Kits include Core skirt panels that customers may use to replace their existing Core skirt panels.

1. On the front or back of the core, do the following:



Note: The front and back skirt panels of the core must be installed before the side skirt panels of the core.

- a. Attach the skirt panel to the skirt bracket by aligning the open slots in the skirt panel with the screw holes in the skirt bracket.

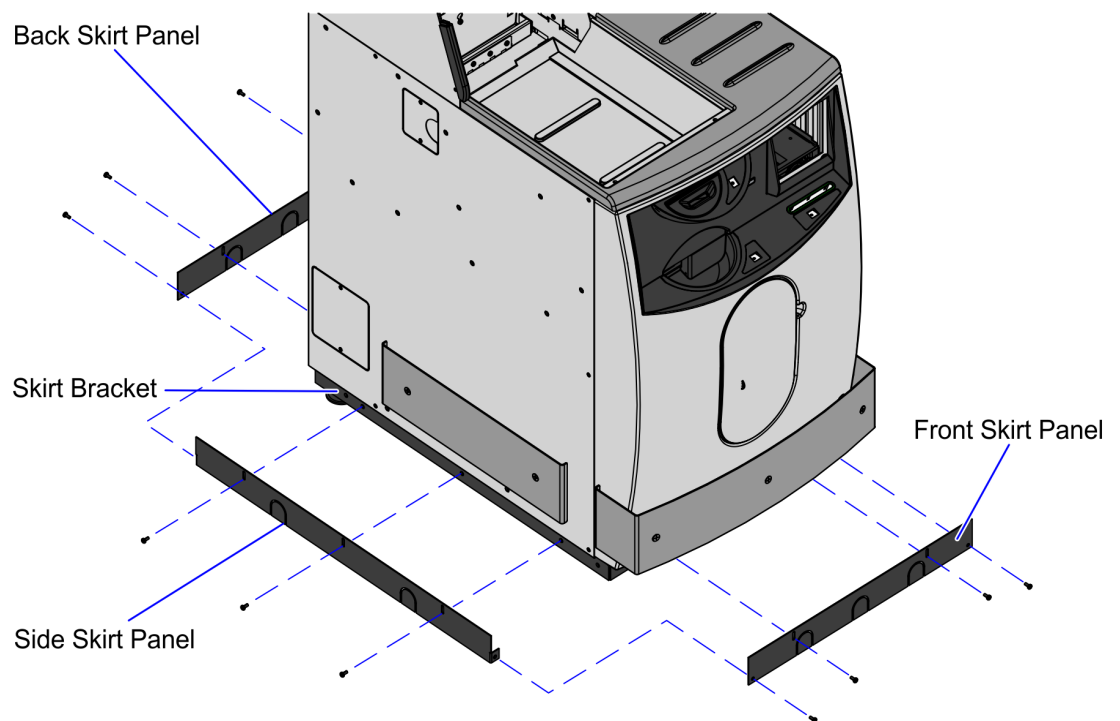

CCP-78634

- b. Secure the skirt panel to the bracket using two screws.
- c. Adjust the skirt panel so that it is flush with the floor.
- d. Tighten the screws to secure the skirt in place.

2. On either sides of the core frame, do the following:



Note: The side skirt panels of the core the must be installed after the front and back skirt panels of the core.

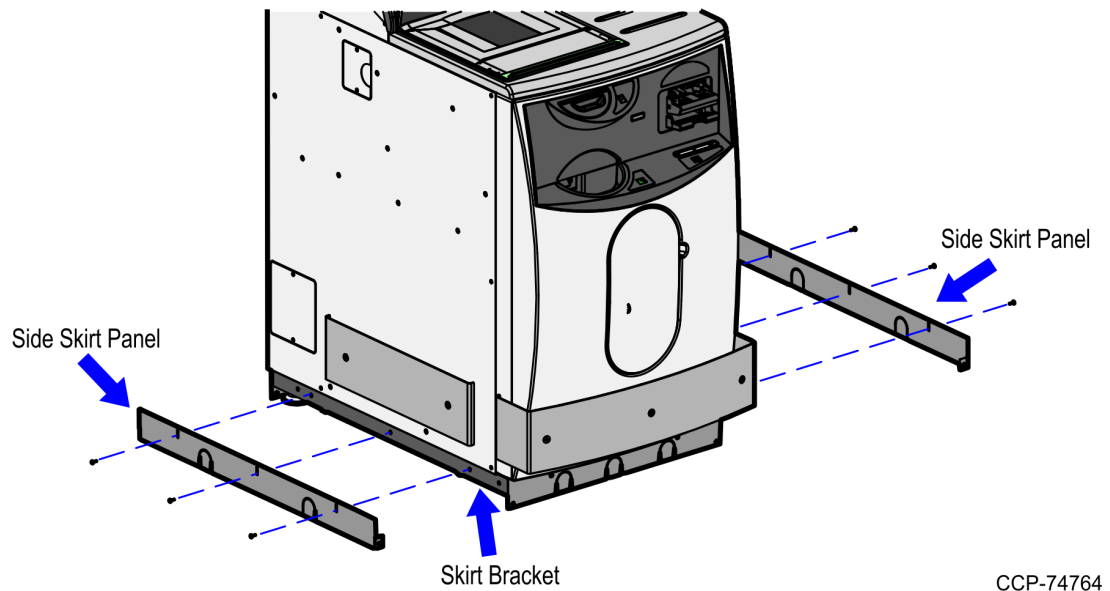

- a. Attach the skirt panel to the skirt bracket by aligning the open slots in the skirt panel with the screw holes in the skirt bracket.
- b. Secure the skirt panel to the bracket using 5 screws.
- c. Adjust the skirt panel so that it is flush with the floor.
- d. Tighten the screws to secure the skirt in place.

Removing Existing Non-Scale Bagwell

To remove an existing Non-Scale 2-Bag Bagwell, follow these steps:



Note: To remove a Non-Scale 1-Bag Bagwell, refer to *7358-K121/K125 Non-Scale 1-Bag Bagwell Upgrade*. To remove a Non-Scale 3-Bag Bagwell, refer to *7358-K165 Non-Scale 3-Bag Bagwell Upgrade*.

1. Detach the Scale Tray from the Bagwell by removing four (4) flat head screws.



Note: Remove bag racks if present.

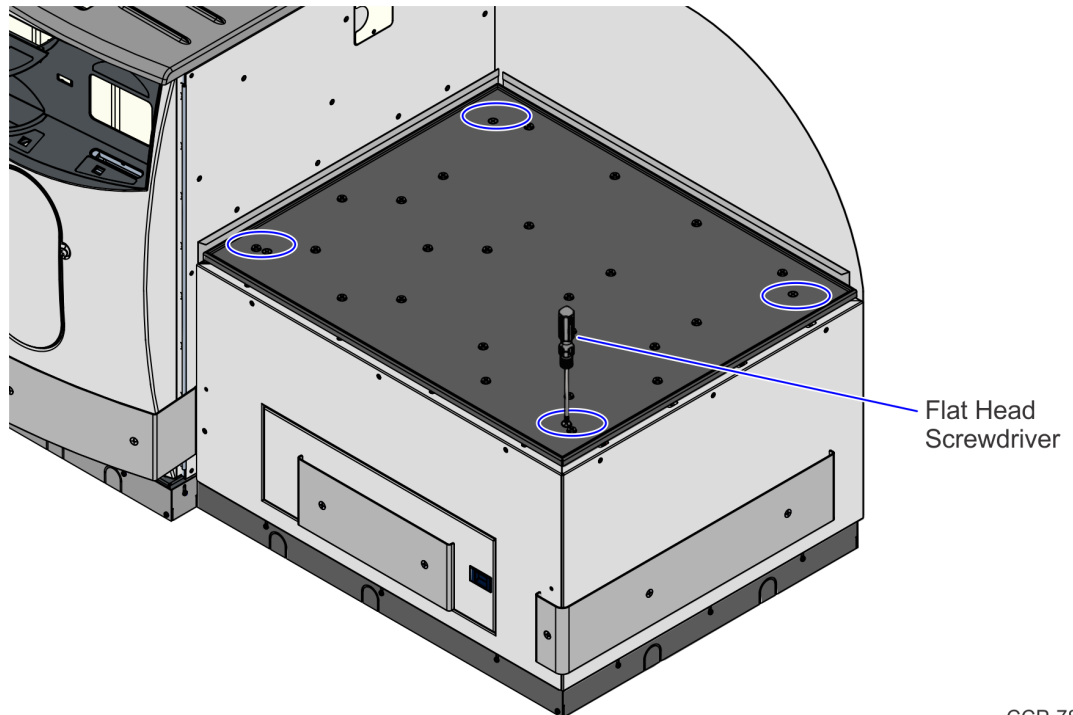

CCP-78078

2. Remove the clear plastic deflectors from the Backsplash and side of the Core.



Note: Leave the Core side deflector in its place if the new Bagwell is attached on the same side.

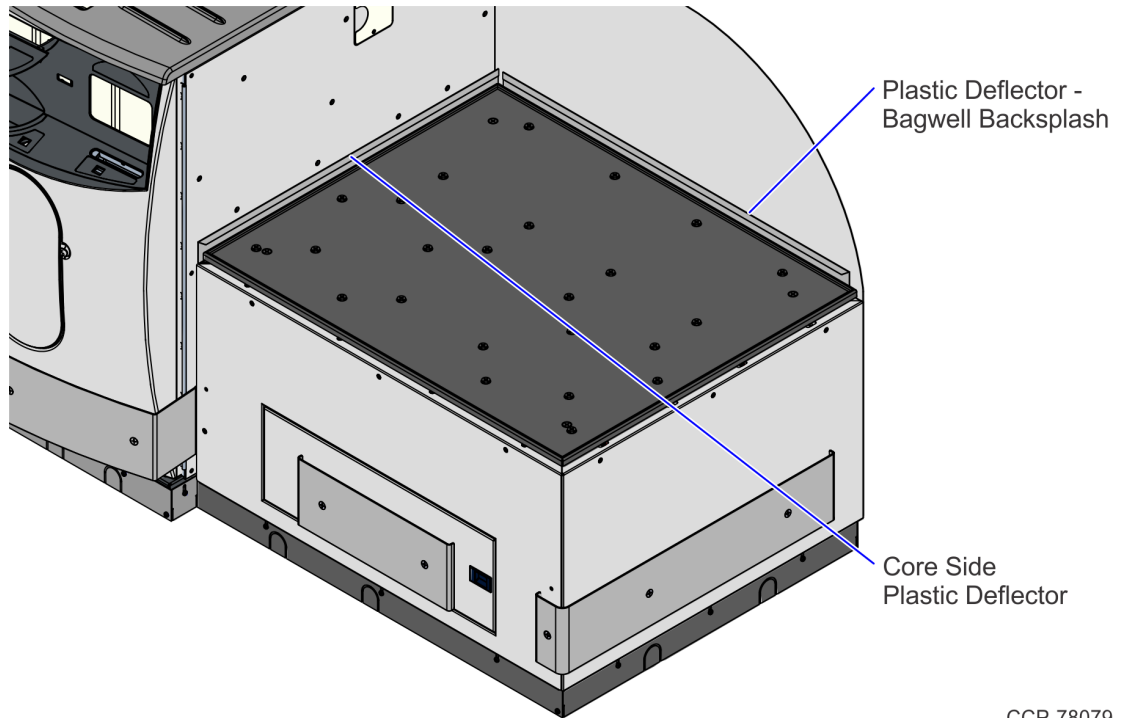

CCP-78079

3. Disconnect the following cables:

- Local Area Network (LAN) Cable from the Customer Interface
- AC Power Out Cables from the Power Strip
- AC Power In Cable from the Power Strip



Note: Remove cables from any routing clips or tie wraps if needed.

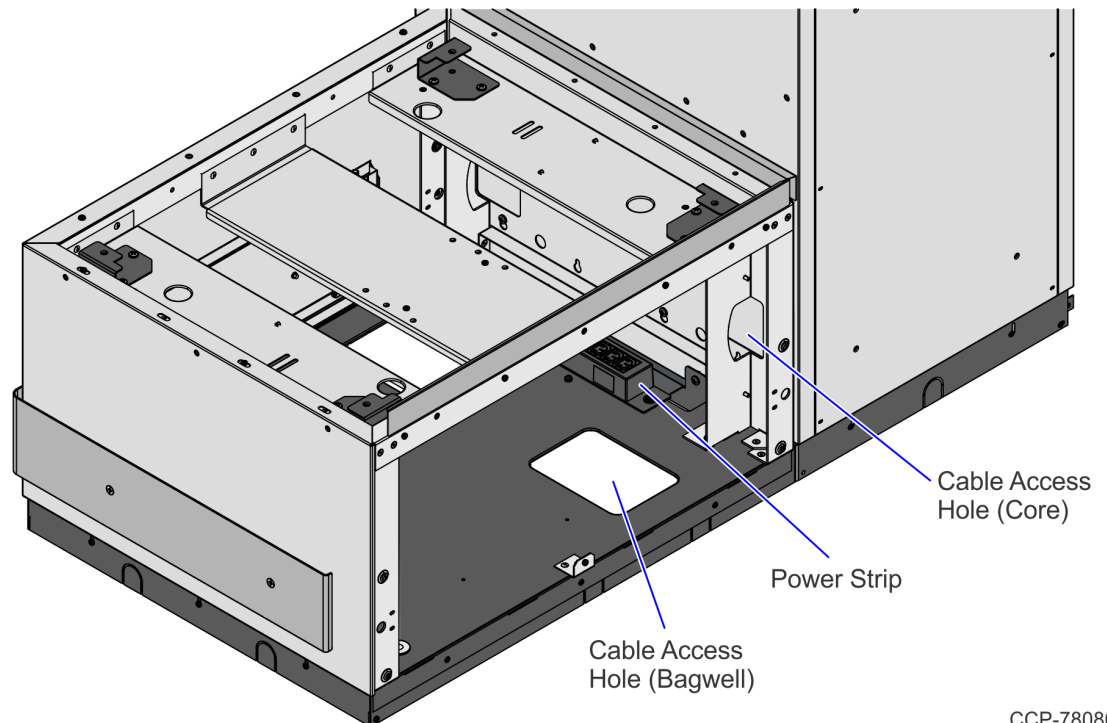

CCP-78080

4. Route the following cables through the cable access hole:

Bagwell Cable Access Hole

- AC Power In Cable

Core Cable Access Hole

- Local Area Network (LAN) Cable
- AC Power Out Cables



Note: The Local Area Network (LAN) Cable and AC Power In Cable may be routed differently depending on the installation conditions.

5. Remove the upper rear screw attaching the Backsplash to the Core.

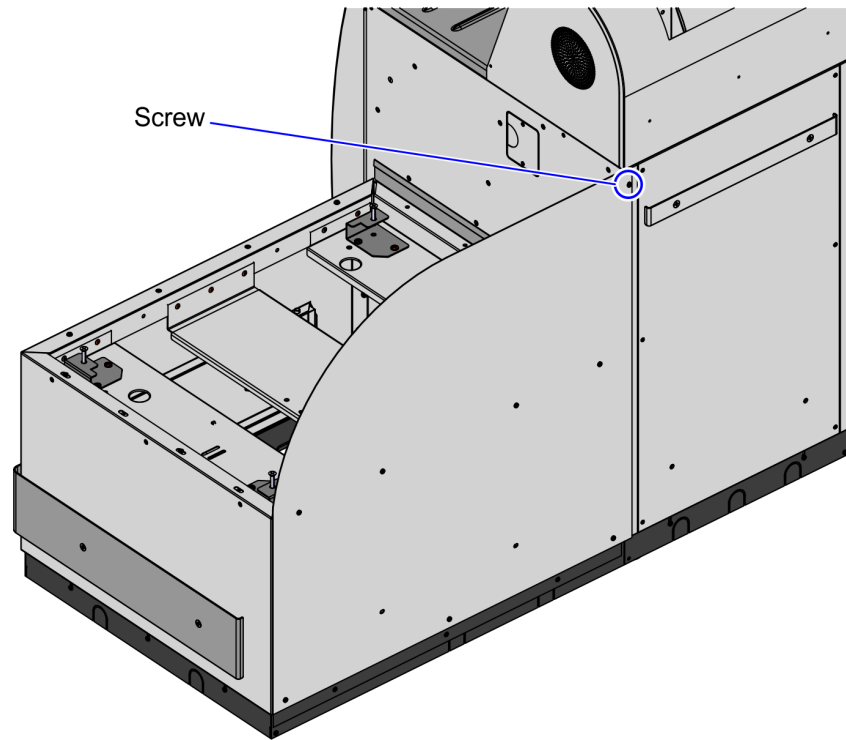

6. Remove the Bagwell by doing the following:
 - a. Remove the two (2) bottom screws attaching the Bagwell to the Core. Screws are located on either side of power strip.

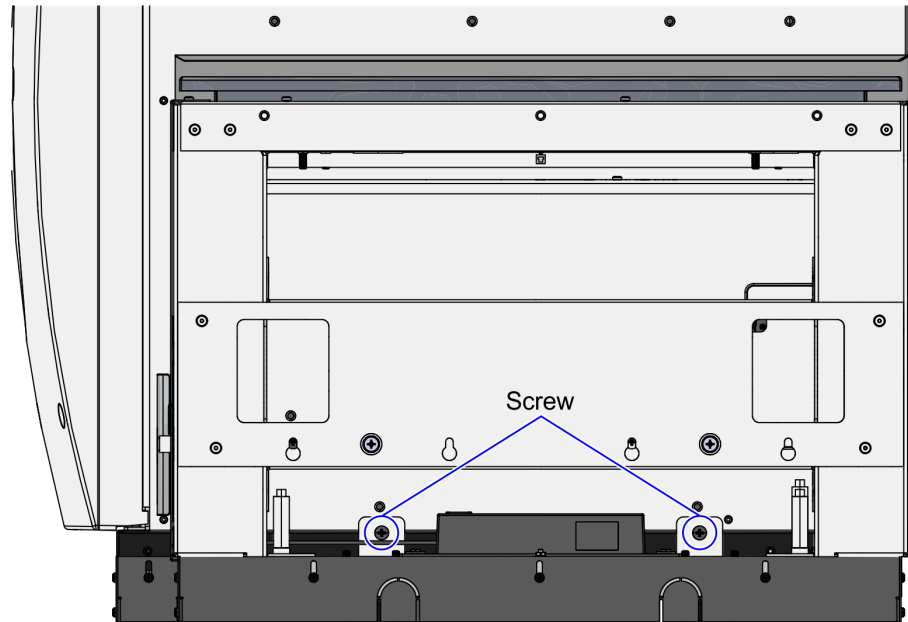

CCP-78082

- b. Loosen the two (2) upper screws, but do not remove.

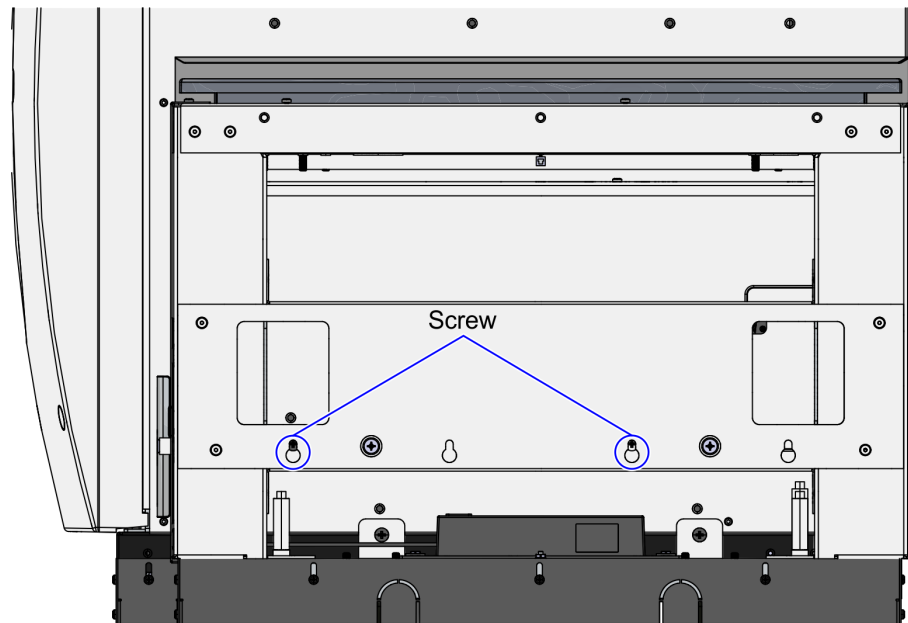

CCP-78083

- c. Lift Bagwell up and away from the Core Cabinet. The upper screw heads will pass through the key holes in the Bagwell side support.

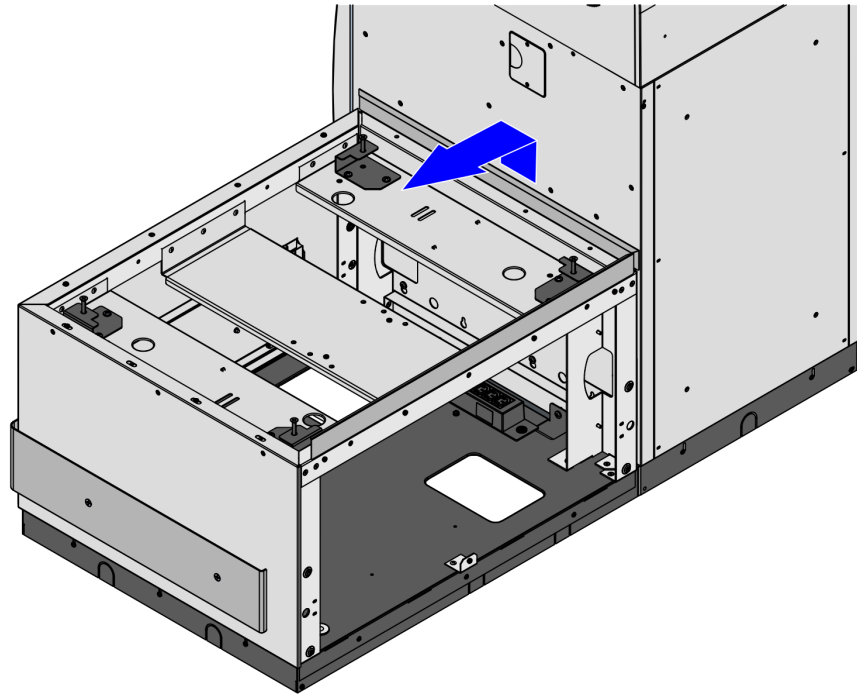

CCP-78084



Note: The two (2) upper screws may be left in place if a new Bagwell will be installed in the same orientation. Otherwise, remove the screws from the side of the Core.

Changing Bagwell Orientation

To change the Bagwell orientation, follow these steps:



Note: These steps should be done before attaching the Bagwell to the Core. For the purpose of illustration only, this procedure shows images using Left-hand (LH) orientation.

1. Detach the Scale Tray from the Bagwell by removing four (4) flat head screws.

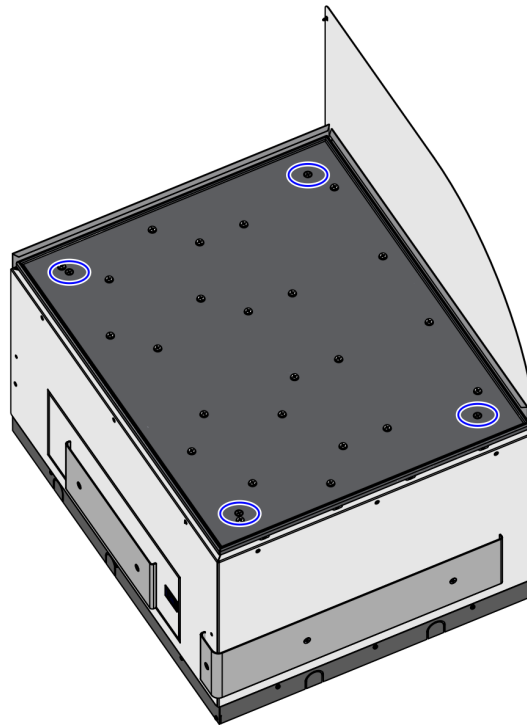

2. Remove the bumpers by doing the following:



Note: Do not remove the front access door bumper

a. Detach the Backsplash the Bagwell by removing seven (7) screws.

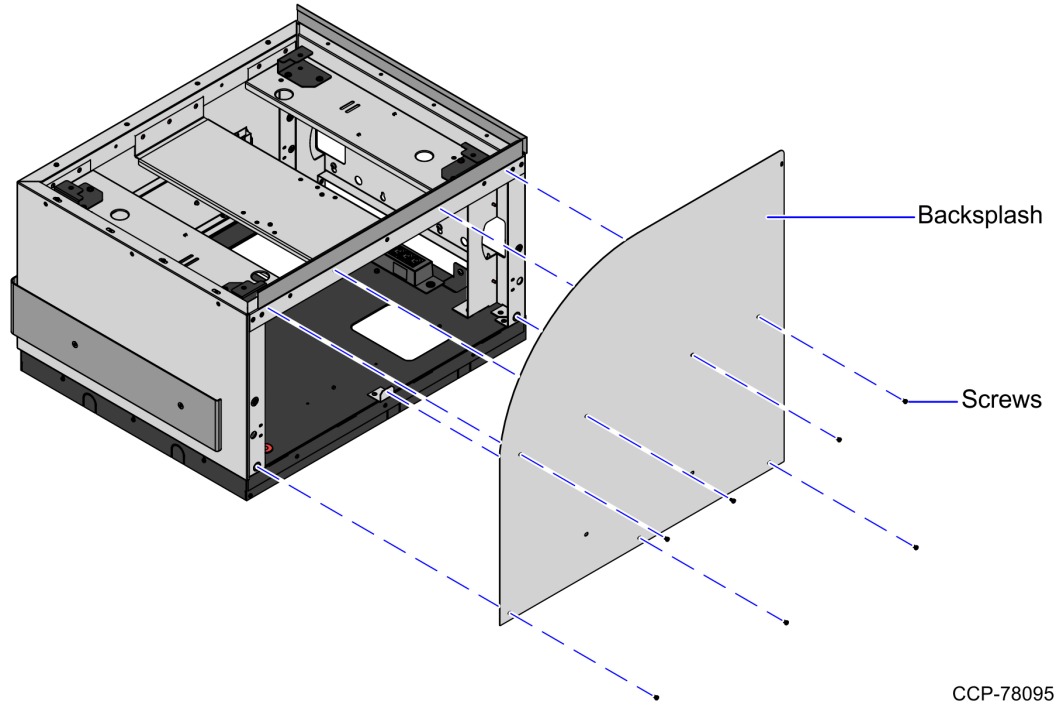

b. Detach the wrap-around side bumper by removing three (3) flat head screws and spacers, as shown in the image below.

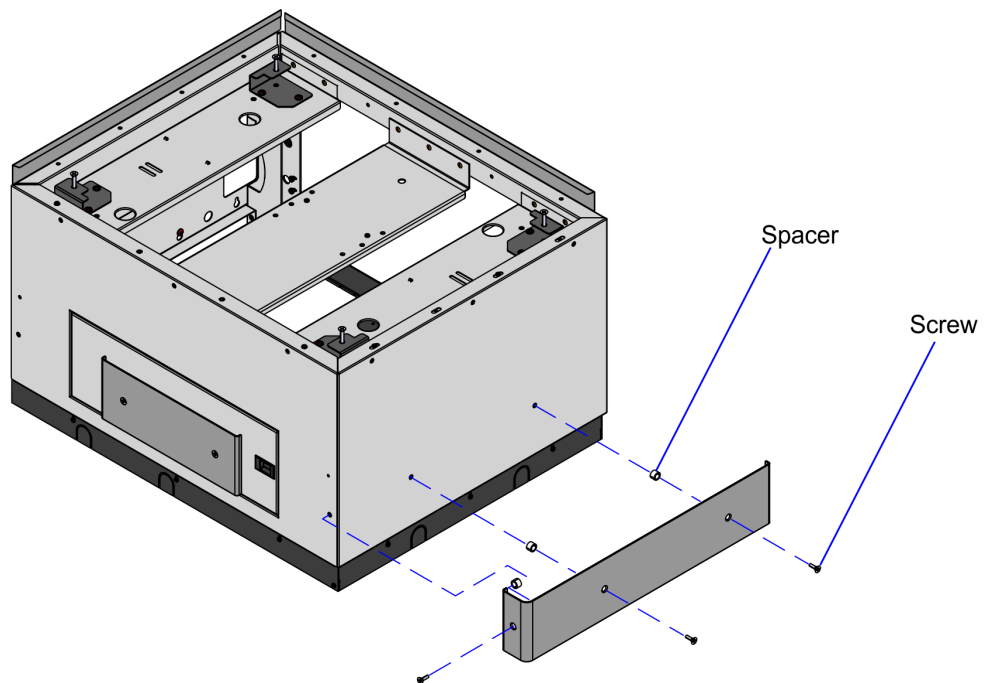

3. Remove two (2) nuts securing the front panel to the Bagwell frame located at the inside corner posts.

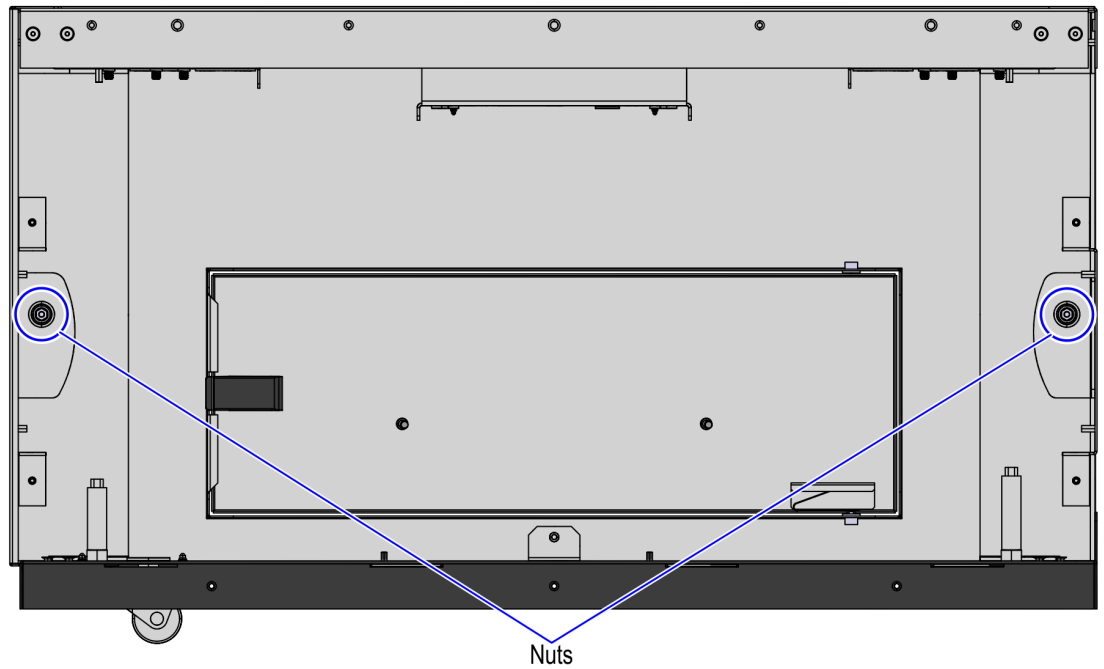

CCP-77375

4. Pull down the front panel and then pull out to disengage from the slots in the Bagwell frame base, as shown in the image below.

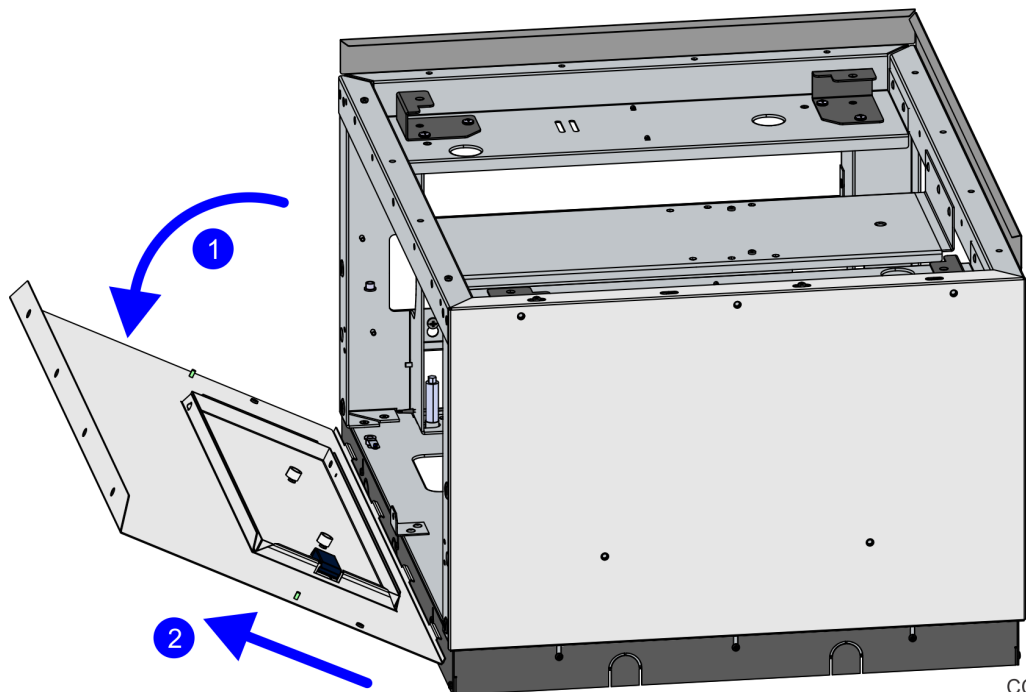

CCP-78091

5. Install the front panel on the opposite side of the Bagwell and secure it with two (2) nuts.



Note: Ensure that the the lower hook features are properly aligned with the slots in the Bagwell frame base.

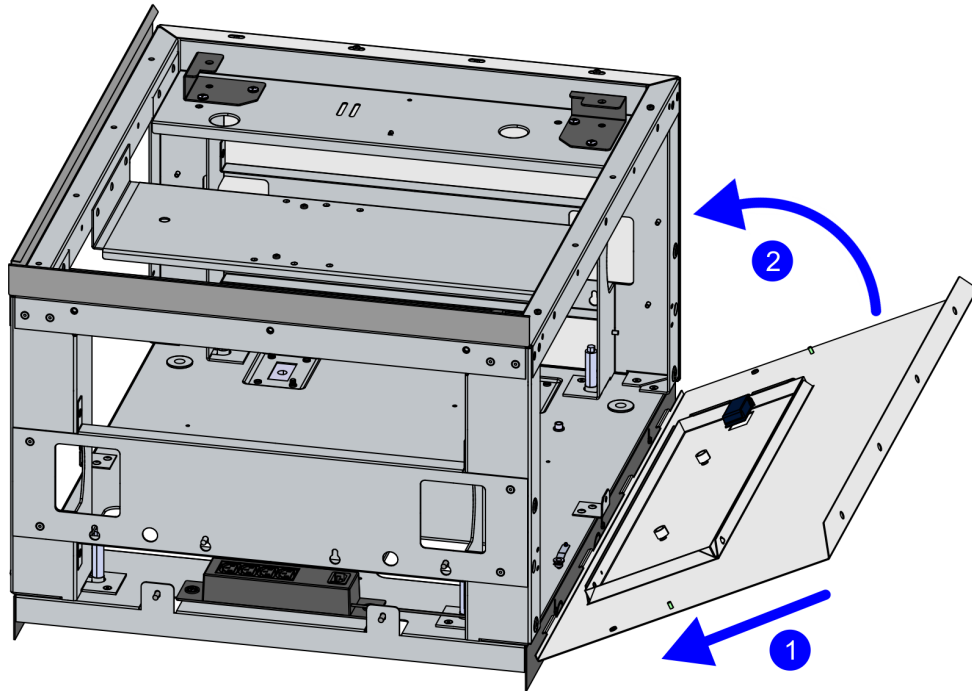

CCP-78092

6. Attach the wrap-around bumper to the Bagwell by using three (3) flat head screws and spacers.

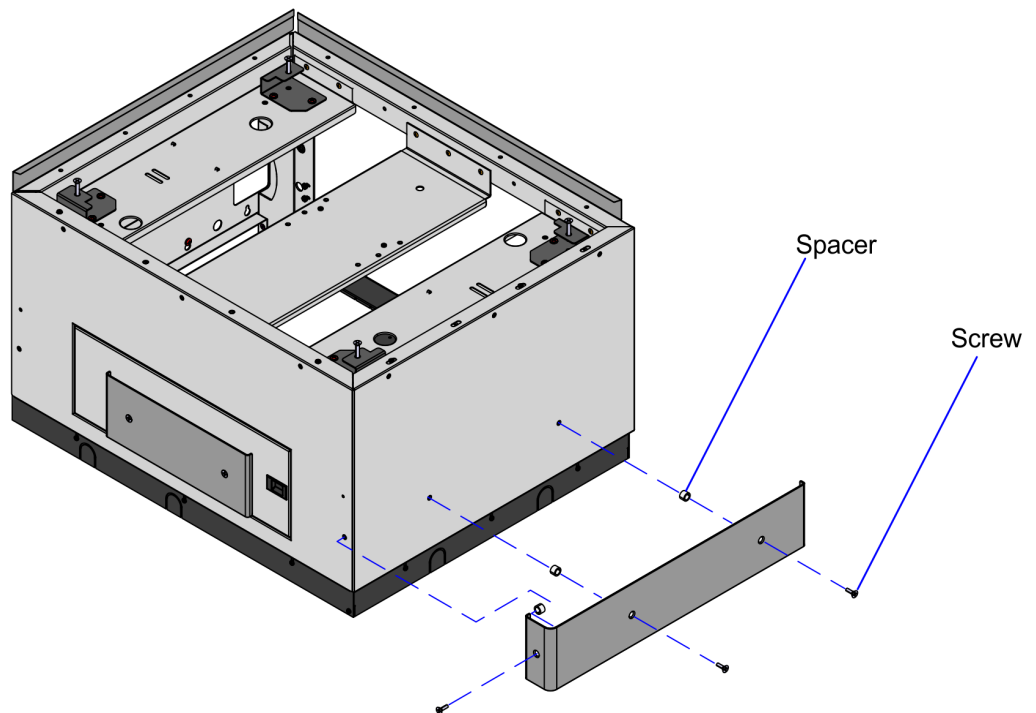

CCP-78089

Installing New Non-Scale Bagwell

To install the new Non-Scale Bagwell, follow these steps:



Note: If changing the Bagwell orientation (Left-Hand or Right-Hand), ensure that the orientation is changed before installing the new Bagwell to the Core. For the purpose of illustration only, this procedure shows images using a Left-hand (LH) orientation unit.

1. Remove the Tray from the Bagwell.
2. Remove the lower access panel from the Core side where the new Bagwell will be attached. Reinstall the access panel on the opposite side of the Core.



Note: This panel does not need to be reinstalled when attaching a Bagwell to a No-Bag Unit.

Right-hand Configuration

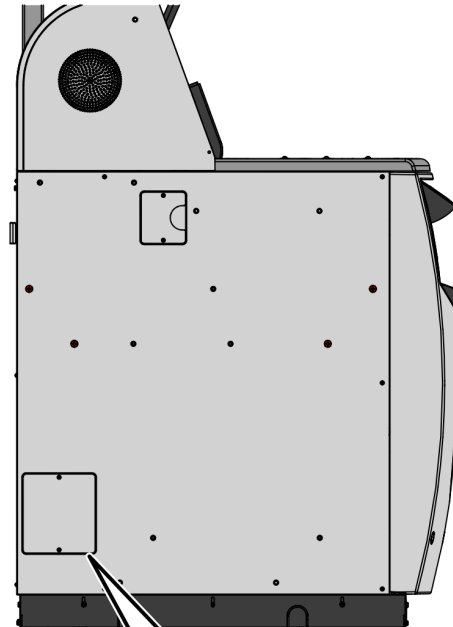

Lower Access Panel

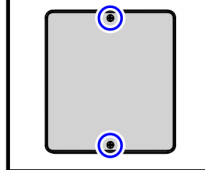

Left-hand Configuration

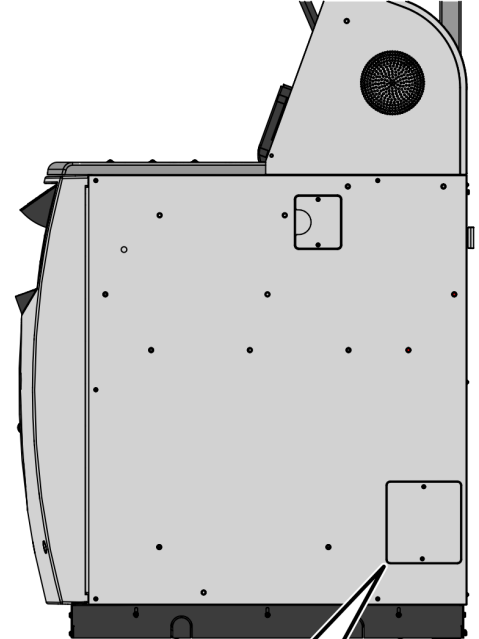

Lower Access Panel

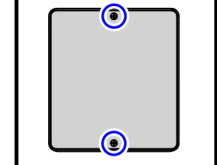

3. Lower all the leveling feet of the Bagwell slightly beyond the height of the casters to assist in lining up the Core and the Bagwell mounting holes.

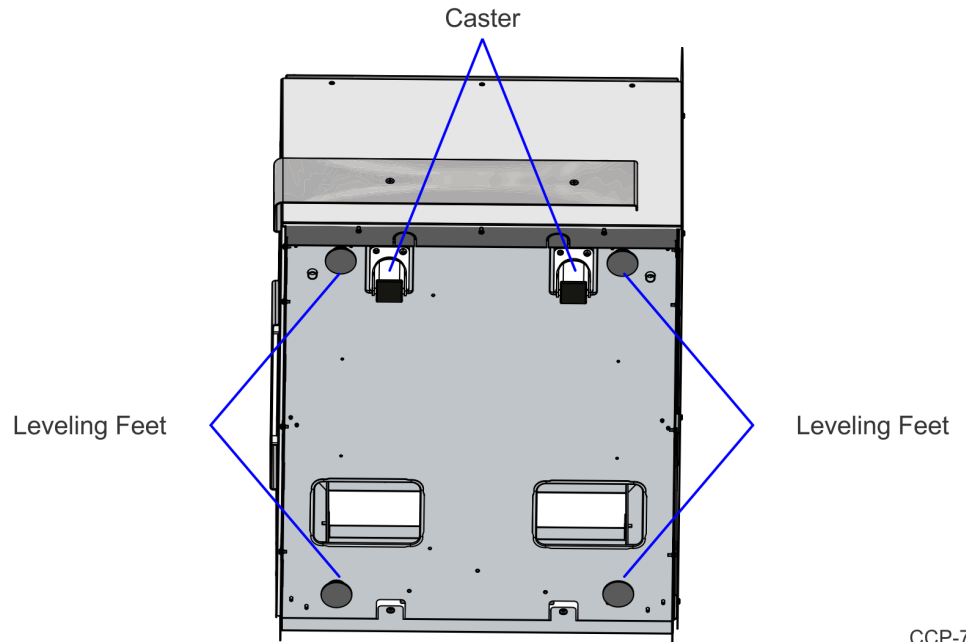

CCP-78094

4. Install the new Backsplash panel using seven (7) screws.

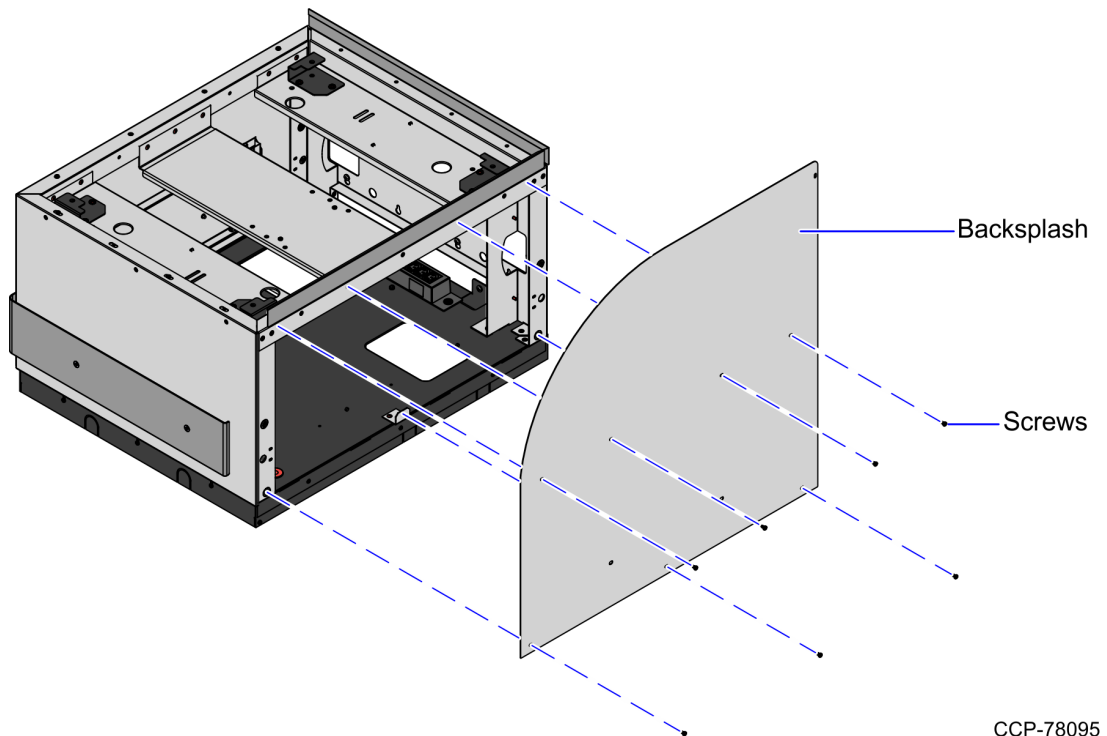

CCP-78095

- If not already present, partially thread the two (2) upper screws on the Bagwell side of the Core. Leave approximately $\frac{1}{4}$ inch of the threads exposed.

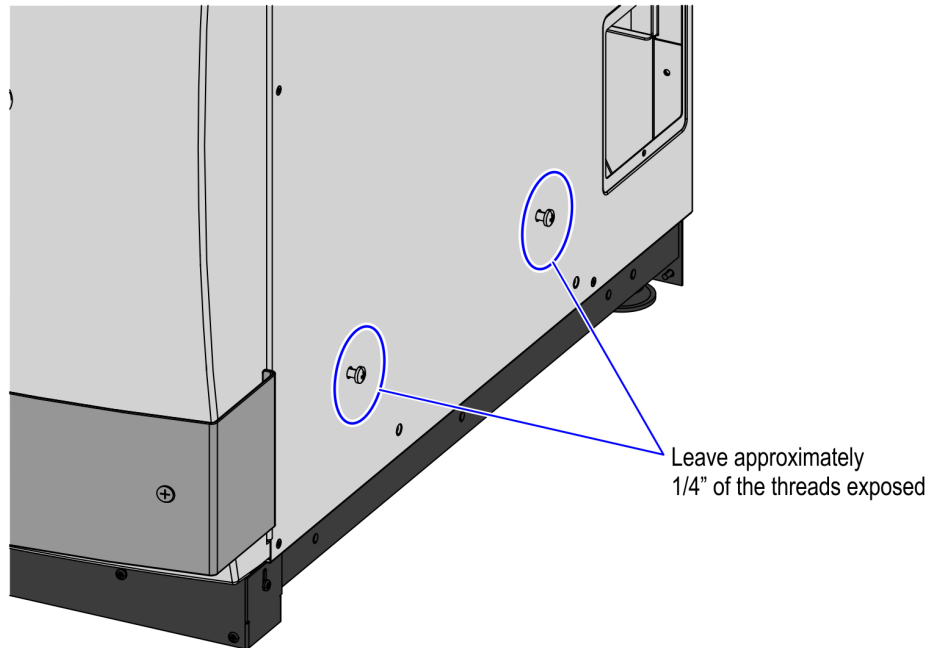

CCP-77329

- Mate the new Bagwell to the Core by lifting the frame up and over the partially threaded screws.



Note: Ensure that the two frontmost key holes on the Bagwell are used.

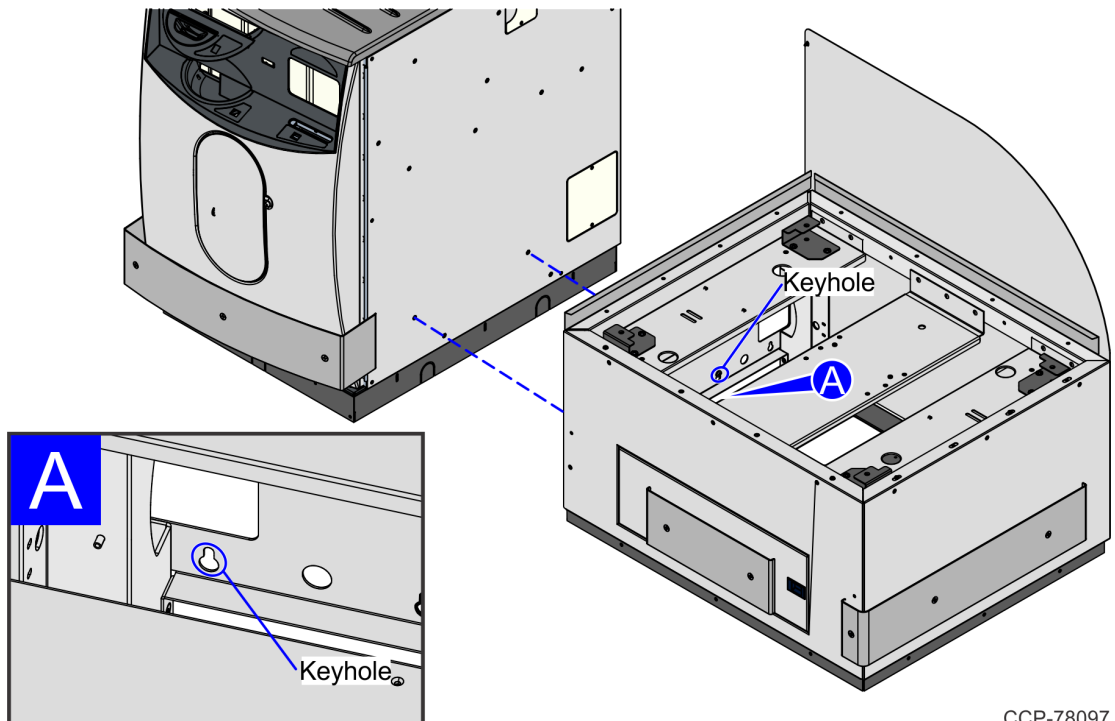

CCP-78097

7. Tighten the two (2) screws and install the two (2) lower screws that connect the Bagwell and the Core.

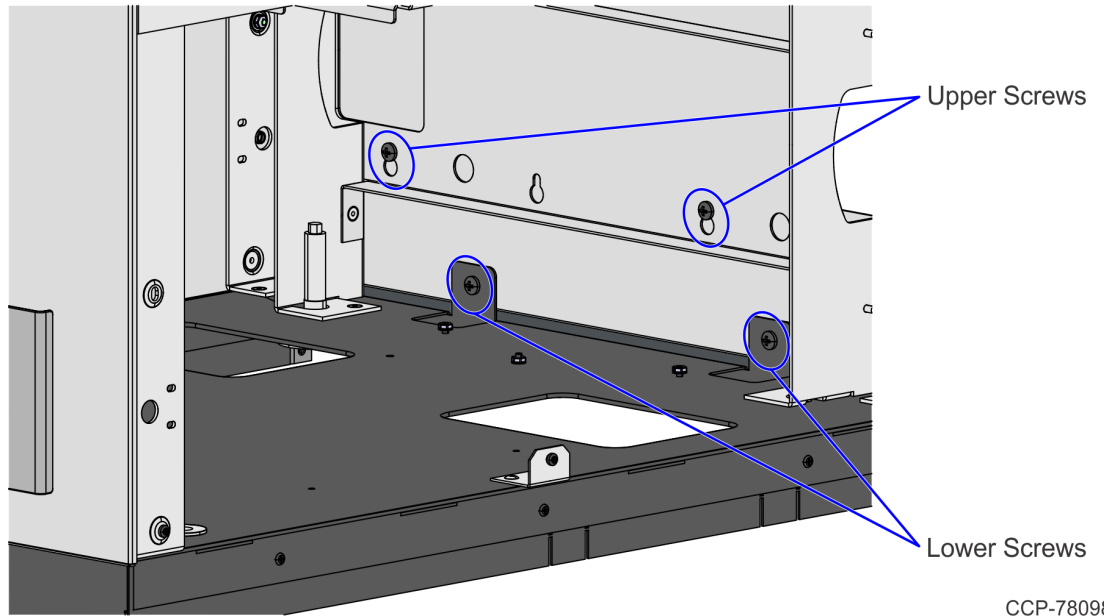

8. Install the upper rear screw attaching the Backsplash panel to the Core.



Note: Adjust the leveling feet if the slot does not line up well.

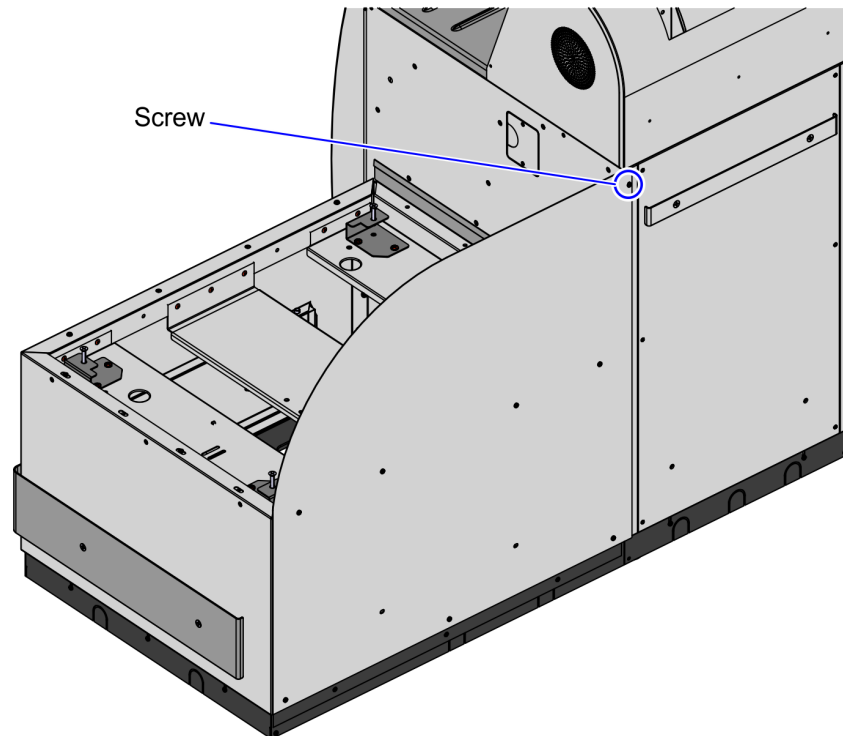

9. Route the following cables through the cable access hole:

Bagwell Cable Access Hole

- AC Power In Cable

Core Cable Access Hole

- Local Area Network (LAN) Cable
- AC Power Out Cables

For more information, refer to [Routing Cables](#) on page 30.

10. Install the Tray on the Bagwell using four (4) flat head screws.



Note: Ensure that the surface marked **BACK** is facing towards the back of the unit.

! Important: Use the correct screw length. Tighten the screws from six to eight pounds.

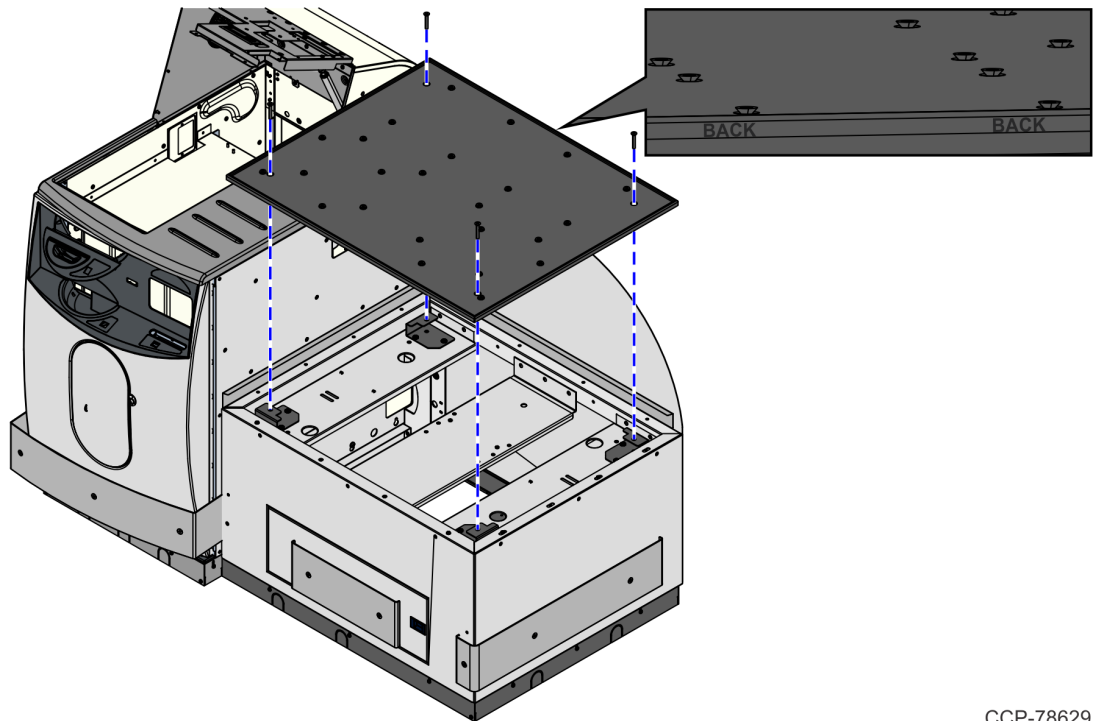

11. Install clear plastic deflectors to the Core side and rear side of the Bagwell. Ensure that the deflectors meet at the rear and Core side corners, and should rest against the Bagwell frame.

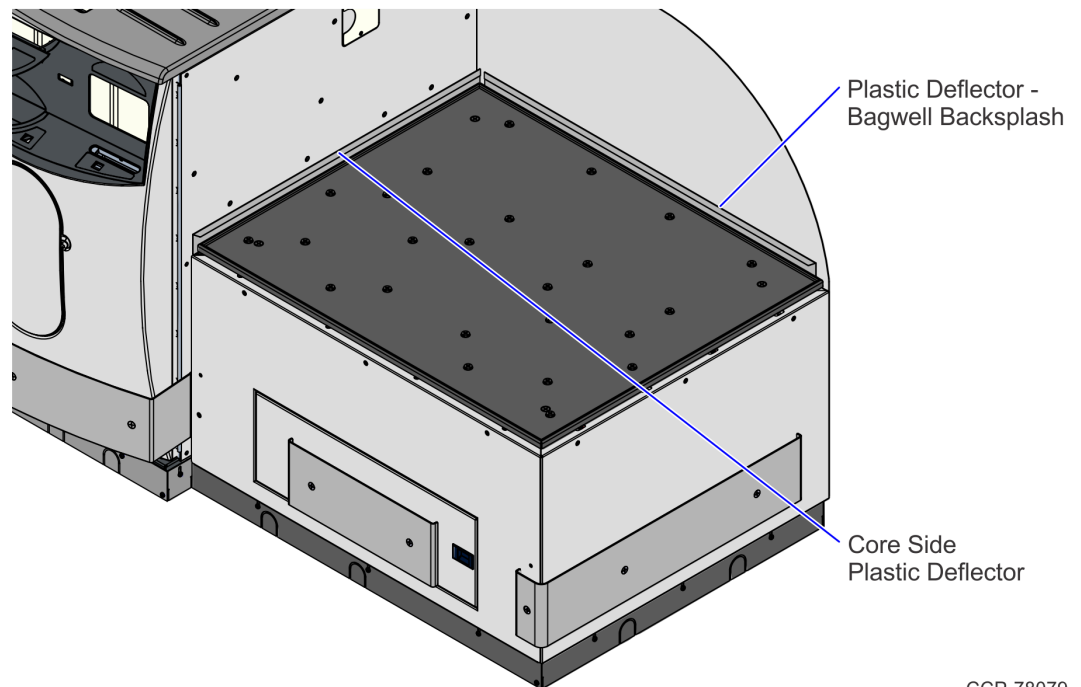

CCP-78079

12. Attach the Bagwell Skirt Panels. For more information, refer to [Installing Bagwell Skirt Panels](#) on the next page.
13. Level the unit and attach the bag racks, if necessary. For more information, refer to the NCR Fastlane SelfServ™ Checkout (7358) Hardware Installation Guide (B005-0000-5263).

Installing Bagwell Skirt Panels

To install Bagwell skirt panels, follow these steps:

1. On the side of the Bagwell, do the following:

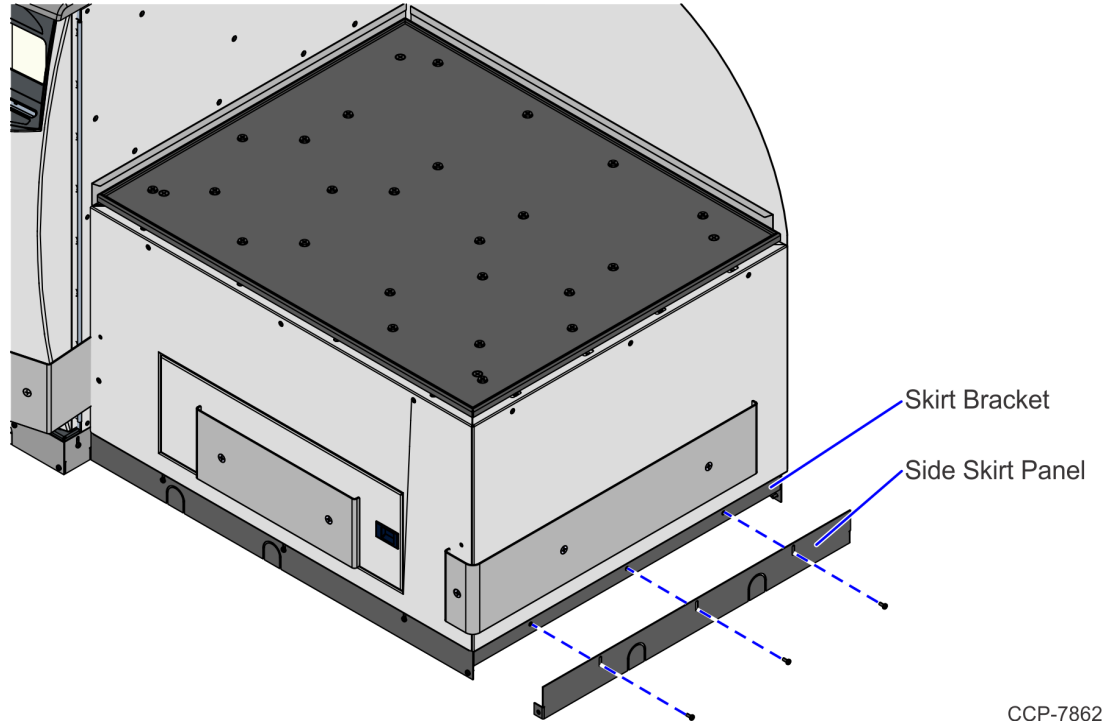

CCP-78628

- a. Attach the skirt panel to the skirt brackets by aligning the open slots in the skirt panel with the screw holes in the skirt bracket.
- b. Secure the skirt panel to the bracket using three (3) screws.
- c. Adjust the skirt panel so that it is flush with the floor.
- d. Tighten the screws to secure the skirt in place.

2. On the front and back of the Bagwell, do the following:



Note: The front and back skirt panels of the Bagwell must be installed after the side skirt panel of the Bagwell.

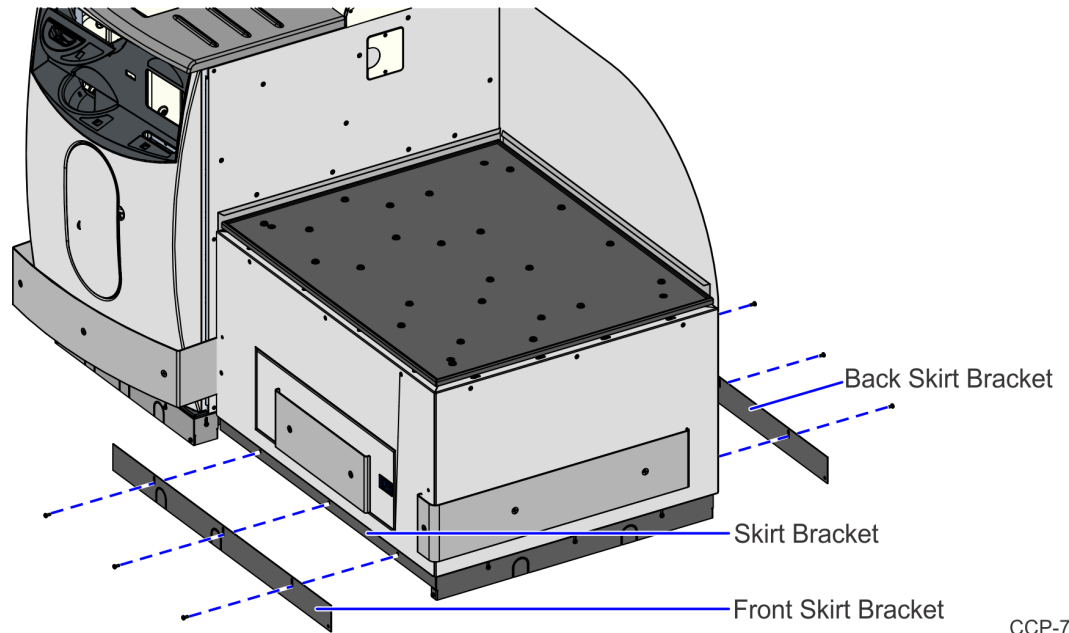

CCP-78627

- a. Attach the front and back skirt panels to the skirt brackets by aligning the open slots of both skirt panels with the screw holes in the skirt bracket.
- b. Secure both skirt panels to the bracket using eight (8) screws.
- c. Adjust the skirt panel so that it is flush with the floor.
- d. Tighten the screws to secure the skirt in place.

Routing Cables

To route cables when installing a new Bagwell, follow these steps:



Note: If a new Bagwell is installed to a No-Bag unit, refer to [Routing Cables for No-Bag unit](#) on page 32.

1. Route the Local Access Network (LAN) Cable from the Core to the Customer Interface through the smaller opening of the Bagwell frame, as shown in the image below.

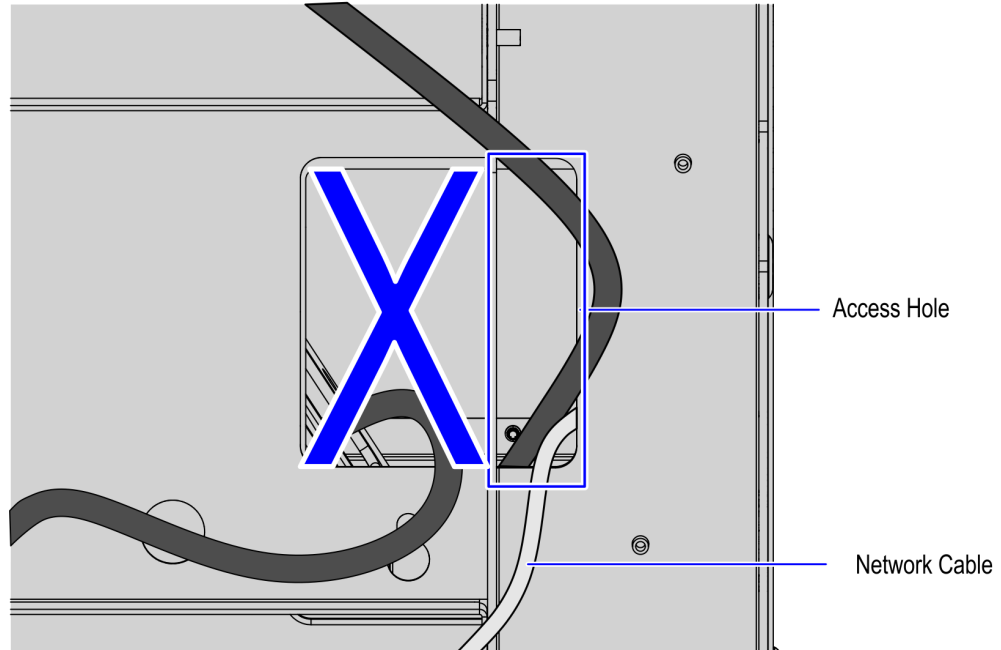

2. Route the AC Power Out and AC Power In cables and then connect to the Power Strip, as shown in the image below.

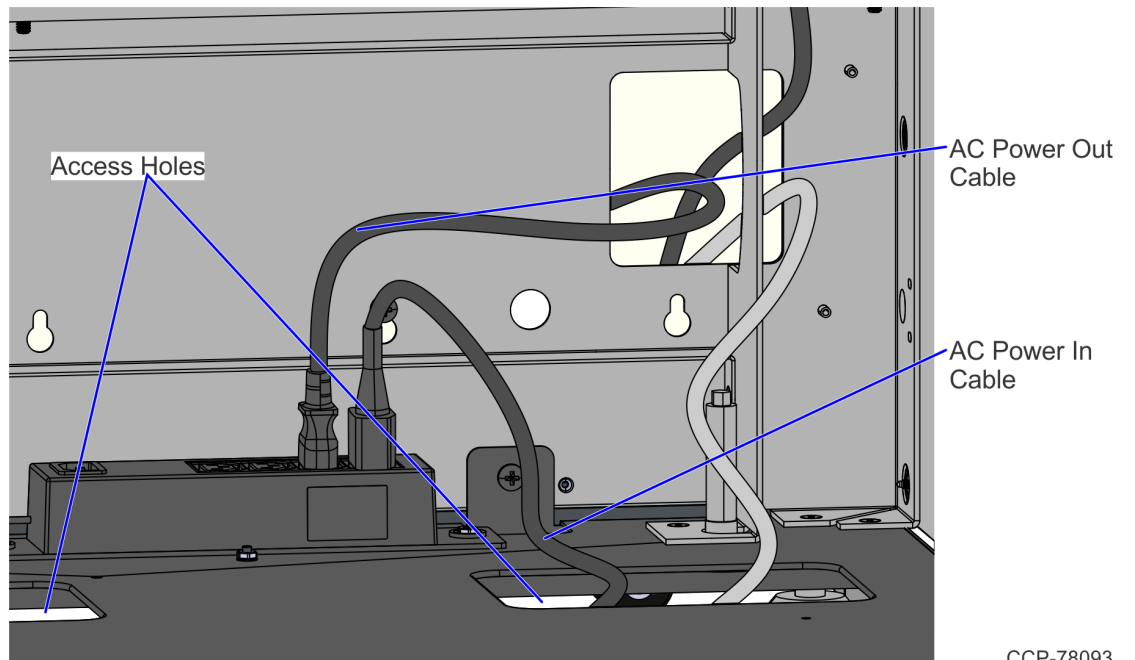

Routing Cables for No-Bag unit

These are additional steps in routing cables when upgrading a No-Bag unit to a 2-Bag unit:

1. Detach the rear Core panel by removing six (6) screws to access the main cable bundle and Power Strip.

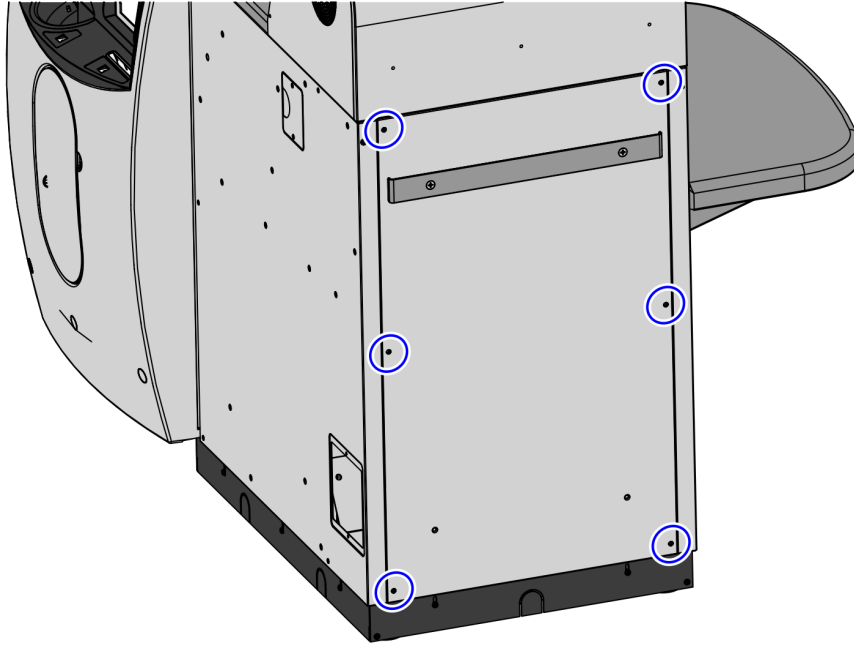

CCP-77769

2. Unplug the AC Power Out and AC Power In cables from the Power Strip. AC Power In Cable will be reused in the new Bagwell. AC Power Out Cable should be routed either through the left-hand or right-hand lower Core access cutout into the new Bagwell.



Note: The Power Strip remains on the rear Core wall but not reused.

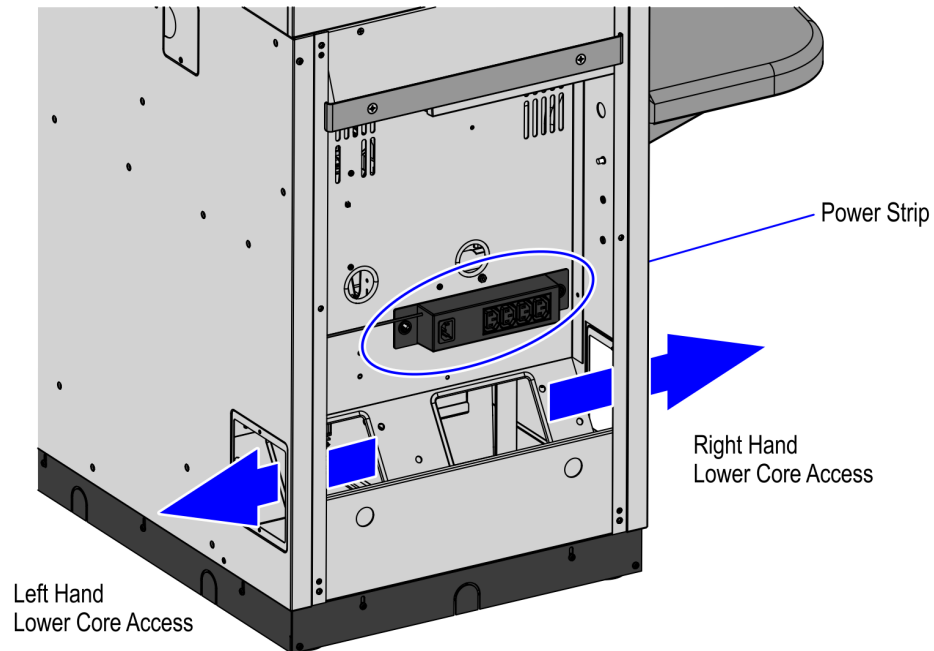

CCP-77348

3. Finish routing the cables into the Bagwell. For more information, refer to [Routing Cables](#) on page 30.