

Kit Instructions

1-Bag Bagwell Upgrade

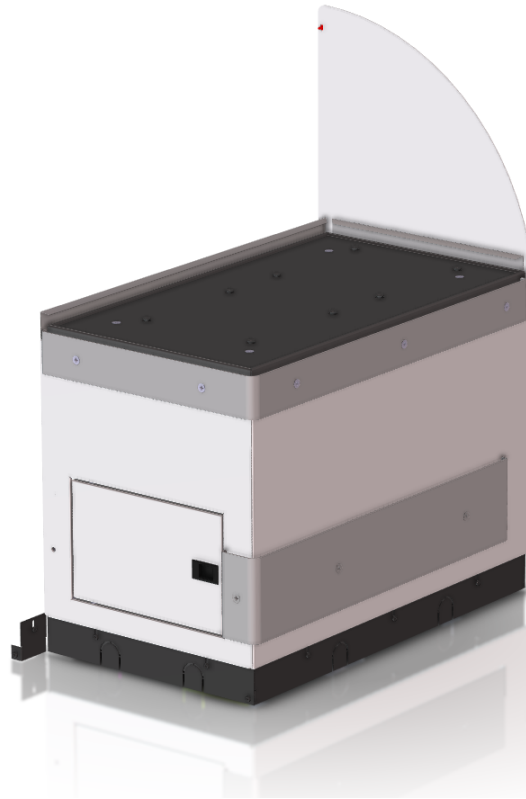

7358-K111
Issue B



The product described in this document is a licensed product of NCR Corporation.

NCR is a registered trademark of NCR Corporation. NCR FastLane SelfServ™ Checkout is a trademark of NCR Corporation in the United States and/or other countries. Other product names mentioned in this publication may be trademarks or registered trademarks of their respective companies and are hereby acknowledged.

The terms HDMI and HDMI High-Definition Multimedia Interface, and the HDMI Logo are trademarks or registered trademarks of HDMI Licensing LLC in the United States and other countries.

Where creation of derivative works, modifications or copies of this NCR copyrighted documentation is permitted under the terms and conditions of an agreement you have with NCR, NCR's copyright notice must be included.

It is the policy of NCR Corporation (NCR) to improve products as new technology, components, software, and firmware become available. NCR, therefore, reserves the right to change specifications without prior notice.

All features, functions, and operations described herein may not be marketed by NCR in all parts of the world. In some instances, photographs are of equipment prototypes. Therefore, before using this document, consult with your NCR representative or NCR office for information that is applicable and current.

Copyright © 2021
By NCR Corporation
Global Headquarters
864 Spring St. NW
Atlanta, GA 30308
United States
All Rights Reserved

Revision Record

Issue	Date	Remarks
A	Oct 2019	First Issue
B	Nov 2021	Updated Kit Contents

1-Bag Bagwell Upgrade

This publication provides procedures for upgrading an NCR FastLane SelfServ™ Checkout (7358), either a No-Bag unit or a unit with an existing Bagwell, with a 1-Bag Bagwell.

The NCR FastLane SelfServ™ Checkout with a Bagging Area (Bagwell) Module or Large Basket (Large Basket) Module can be configured for either Left-hand (LH) orientation or Right-hand (RH) orientation, which refers to the direction customers scan and bag items.

- **Left-hand (LH) orientation**—Customers scan from left to right.
- **Right-hand (RH) orientation**—Customers scan from right to left.



Note: The orientation of the unit is determined by the position of the Lower Core (Cabinet) Module in relation to the Bagwell or Large Basket.

Example: The Left-hand (LH) unit has the Cabinet positioned on the left side of the Bagwell or Large Basket.

Kit Contents

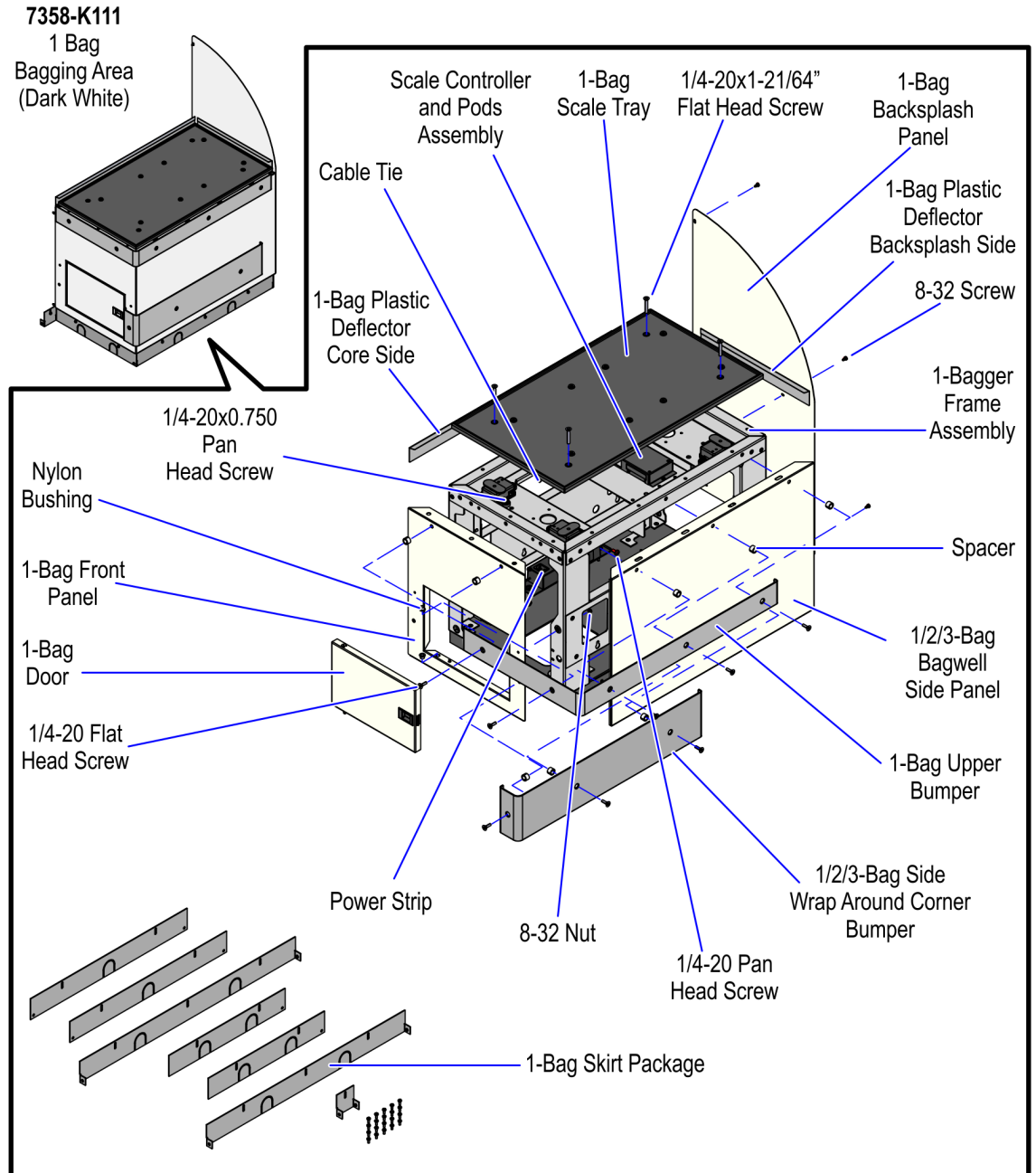

CCP-77727

Part Number	Description
497-0526492	Kit - 1 Bagwell Module, Bumpers, Skirts (Dark White)
795-0283431	Assembly - 1 Bag Door (NCR Dark White)
795-0137231	Panel - Backsplash - 1 Bag (NCR Dark White)

Part Number	Description
795-0137131	Panel - 1 Bag - Front (NCR Dark White)
795-0133331	Panel - 1/2/3 Bagwell Side (NCR Dark White)
795-0281601	Hole Cover Label - (NCR Dark White)
497-0526949	Skirt-1-Bag BOM Package
497-0528666	Assembly - 1 Bagger Frame with Leveling Feet and Casters
497-0472267	1-Bag Scale Tray with Bag Rack Hardware
497-0467814	Assembly - Scale Controller and Pods
497-0457365	Plastic Deflector - Backsplash Side - 1-Bag
497-0457054	Black Nylon Spacer 15mm OD x 10.4mm ID x 10mm L (8 pcs)
497-0455519	Plastic Deflector - Core Side
497-0518271	Bumper - 1-Bag Upper
497-0445077	Cable: (Black) 4M USB +Power (12V) to 2x4 Latch-N-Lok
009-0005930	Cable Tie-Snap in Mounting
006-8612492	Screw - ¼-20 x 0.750 in, Phillips Flat Head, 82 Degree, Machine Thread, Zinc-Plated Steel (8 pcs)
006-8612446	Screw - 8-32 x 0.375 in Phil Pan, Self Tapping - Type F (7 pcs)
006-8616060	Screw - ¼-20 x 0.75 in, Pan Head, Phillips, Zinc Plated Steel (8 pcs)
006-8623998	Screw - ¼-20 x 1-21/64 in, Phillips Flat Head, 82 Degree, Machine Thread, Zinc-Plated Steel (4 pcs)
006-8611505	Bushing, Nylon (2 pcs)
006-8611143	Nut Keps, 8-32, Steel, Blue Zinc (5 pcs)
006-8604541	Screw, ¼-20 x ½, Pan Head, Phillips (4 pcs)
497-0421485	Power Strip, IEC 4-POS, Plastic Case
497-0426042	Bag - 2 and 3.5 Bagger, LHC and RHC, Input Belt
497-0518277	Bumper - 1, 2, 3 Bag Side, Wrap Around Corner
497-0513382	Label - Multiple Power Sources/Disconnect Power Caution
007-9714414	Tiestrap Plain 5.60 LG (4 pcs)
* 497-0423108	Instructions - Kit (Reference Sheet)

* Items marked with an asterisk are not called out on the image.

Installation Procedures

Installing the Bagwell upgrade involves the following procedures:

- [Removing Existing Bagwell](#) on the facing page.
- [Changing Bagwell Orientation](#) on page 10.



Note: This procedure may be optional.

- [Installing New Bagwell](#) on page 16.
- [Installing Bagwell Skirt Panels](#) on page 23.
- [Routing Cables](#) on page 25.

Removing Existing Bagwell

To remove an existing 1-Bag Bagwell, follow these steps:



Note: To remove a 2-Bag Bagwell, refer to . To remove a 3-Bag Bagwell, refer to .

1. Detach the Scale Tray from the Bagwell by removing four (4) flat head screws.



Note: Remove bag racks if present.

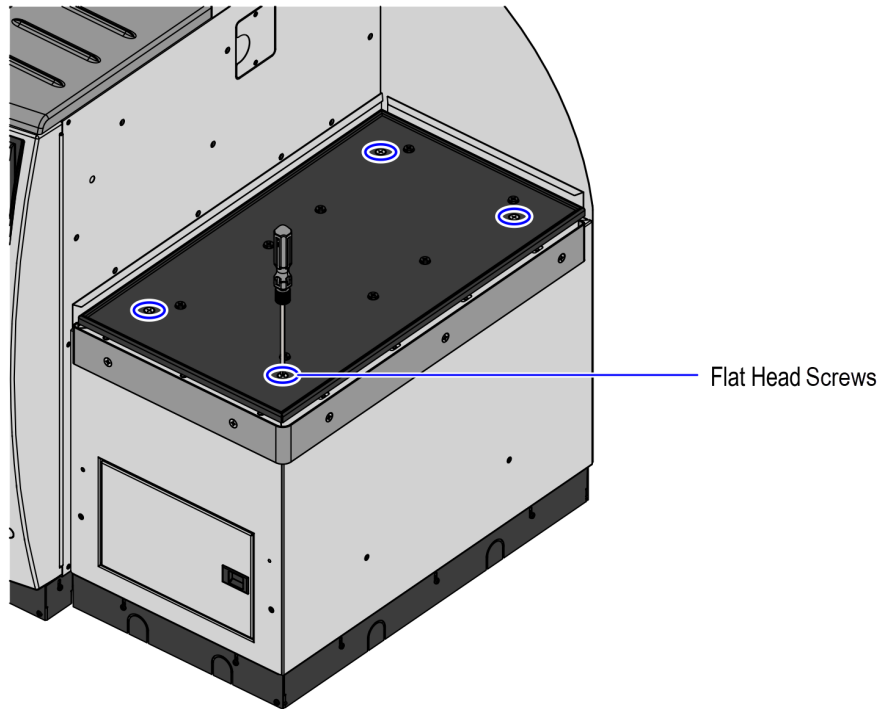

2. Remove the clear plastic deflectors from the Backsplash and side of the Core.



Note: Leave the Core side deflector in its place if the new Bagwell is attached on the same side.

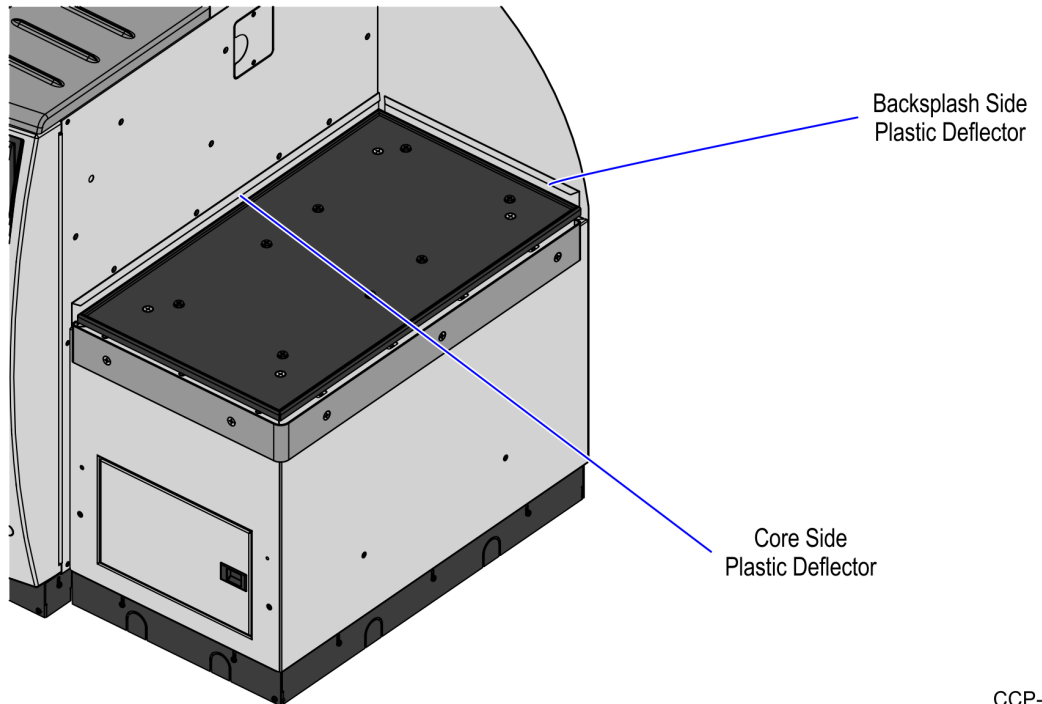

CCP-77312

3. Disconnect the following cables:

- USB Power Cable from the Scale Controller
- Local Area Network (LAN) Cable from the Customer Interface
- AC Power Out Cables from the Power Strip
- AC Power In Cable from the Power Strip



Note: Remove cables from any routing clips or tie wraps if needed.

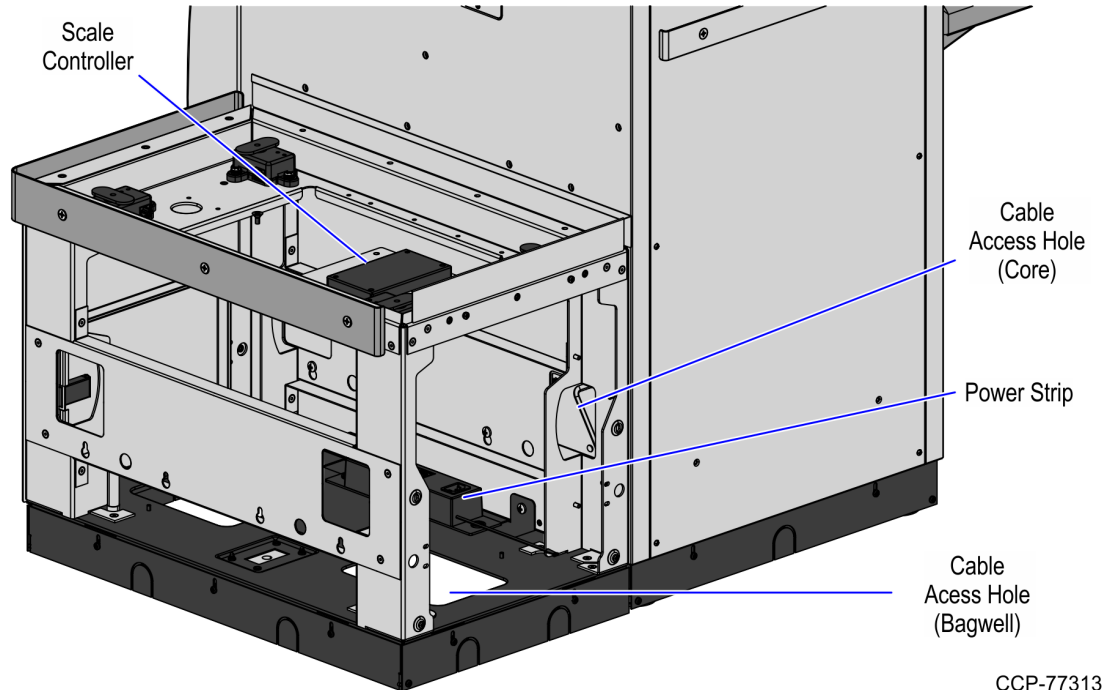

4. Route the following cables through the cable access hole:

Bagwell Cable Access Hole

- AC Power In Cable

Core Cable Access Hole

- USB Power Cable
- Local Area Network (LAN) Cable
- AC Power Out Cables



Note: The Local Area Network (LAN) Cable and AC Power In Cable may be routed differently depending on the installation conditions.

5. Remove the upper rear screw attaching the Backsplash to the Core.

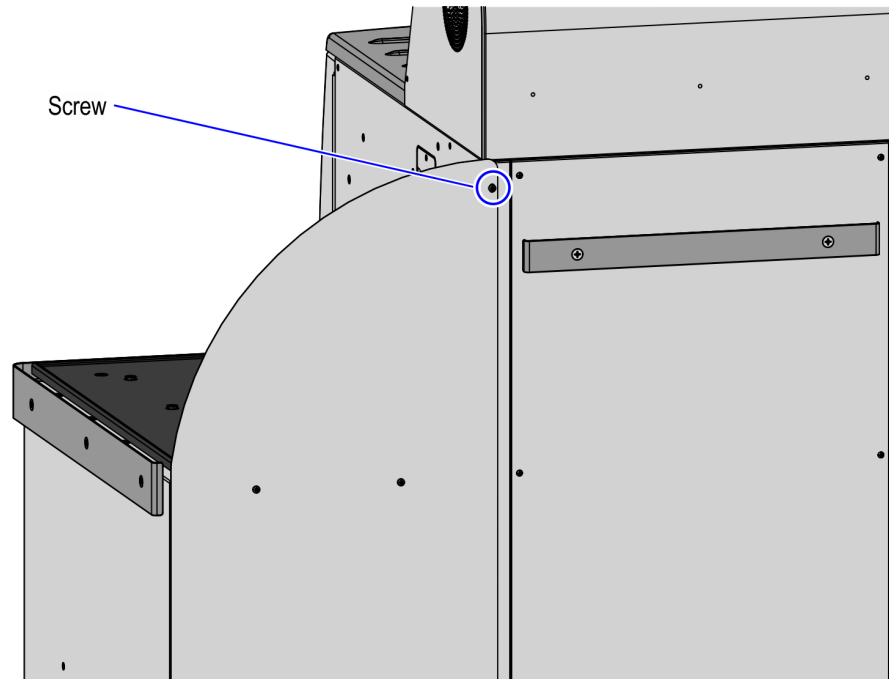

CCP-77314

6. Remove the Bagwell by doing the following:
 - a. Remove the two (2) bottom screws attaching the Bagwell to the Core. Screws are located on either side of power strip.

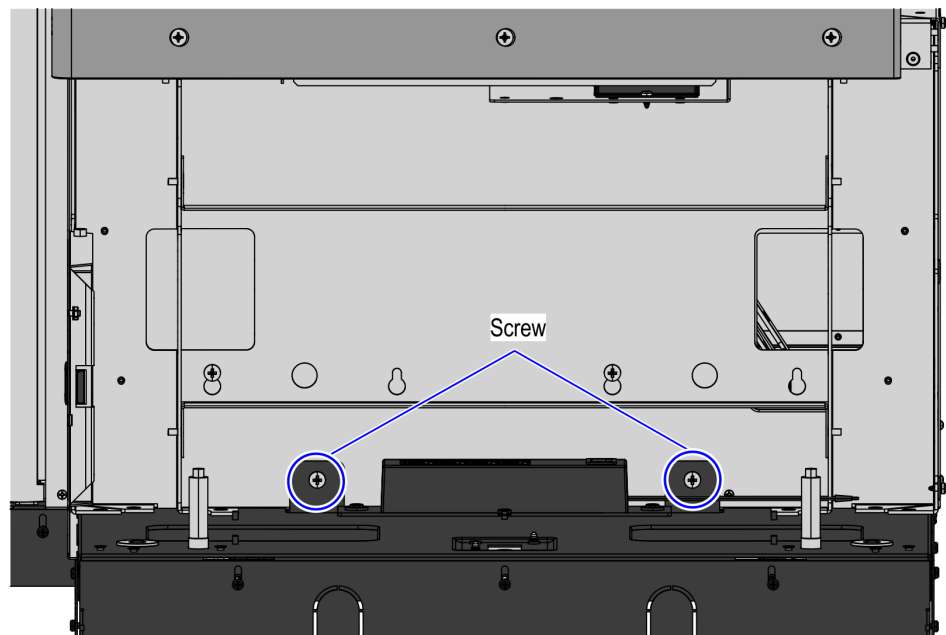

CCP-77315

- b. Loosen the two (2) upper screws, but do not remove.

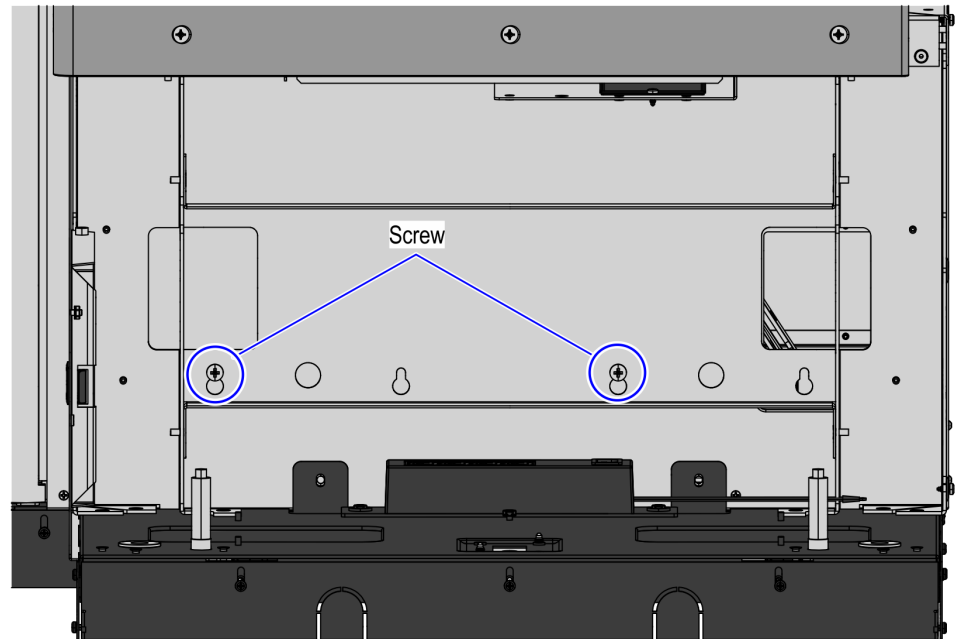

CCP-77316

- c. Lift Bagwell up and away from the Core Cabinet. The upper screw heads will pass through the key holes in the Bagwell side support.

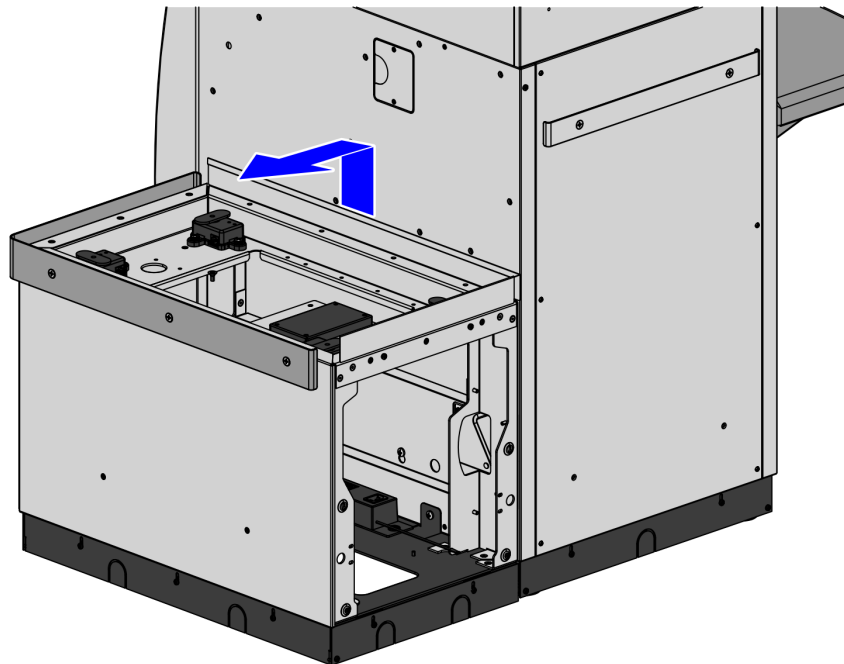

CCP-77317



Note: The two (2) upper screws may be left in place if a new Bagwell will be installed in the same orientation. Otherwise, remove the screws from the side of the Core.

Changing Bagwell Orientation

To change the Bagwell orientation, follow these steps:



Note: These steps should be done before attaching the Bagwell to the Core. For the purpose of illustration only, this procedure shows images using Left-hand (LH) orientation.

1. Detach the Scale Tray from the Bagwell by removing four (4) flat head screws.

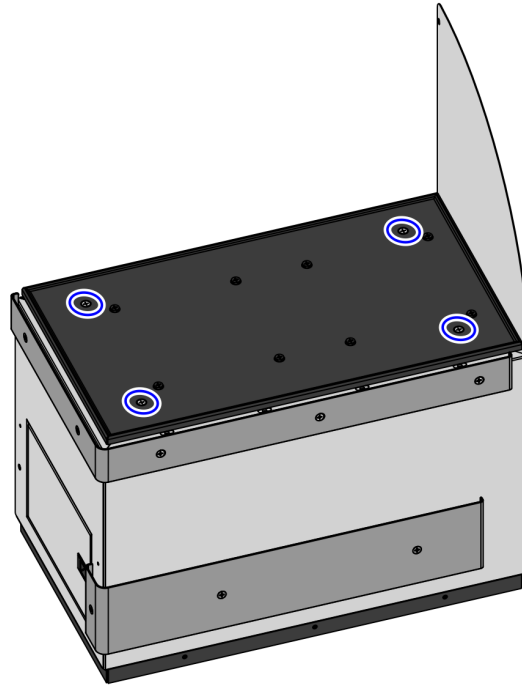

CCP-77318

2. Remove the bumpers by doing the following:



Note: Do not remove the front access door bumper.

- a. Detach the lower-rear bumper from the Bagwell by removing two (2) flat head screws.

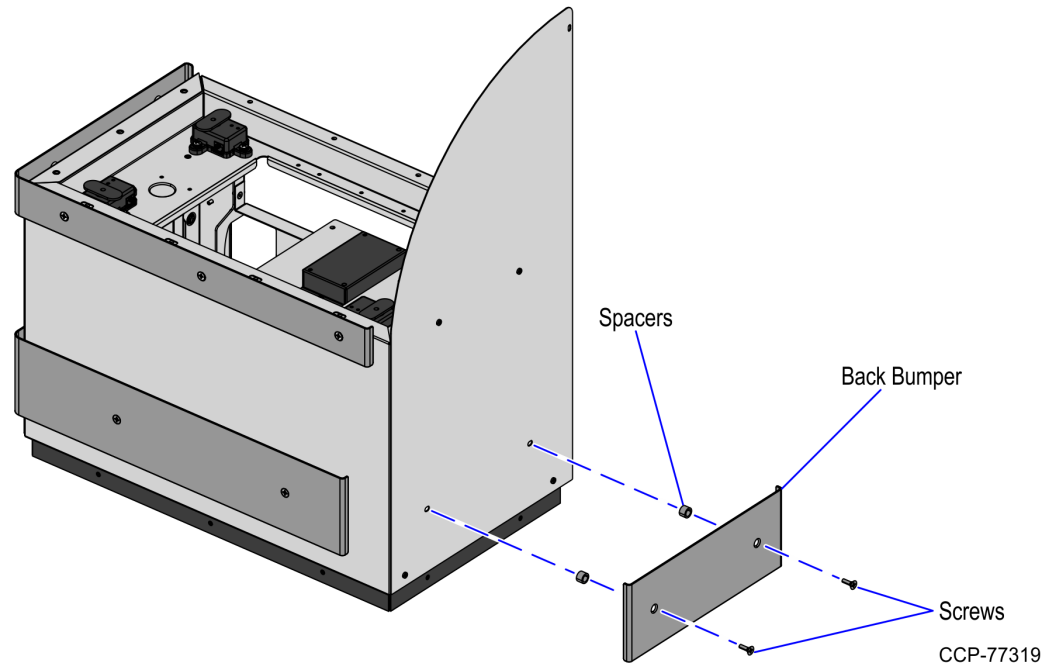

- b. Detach the Backsplash from the Bagwell by removing four (4) flat head screws.

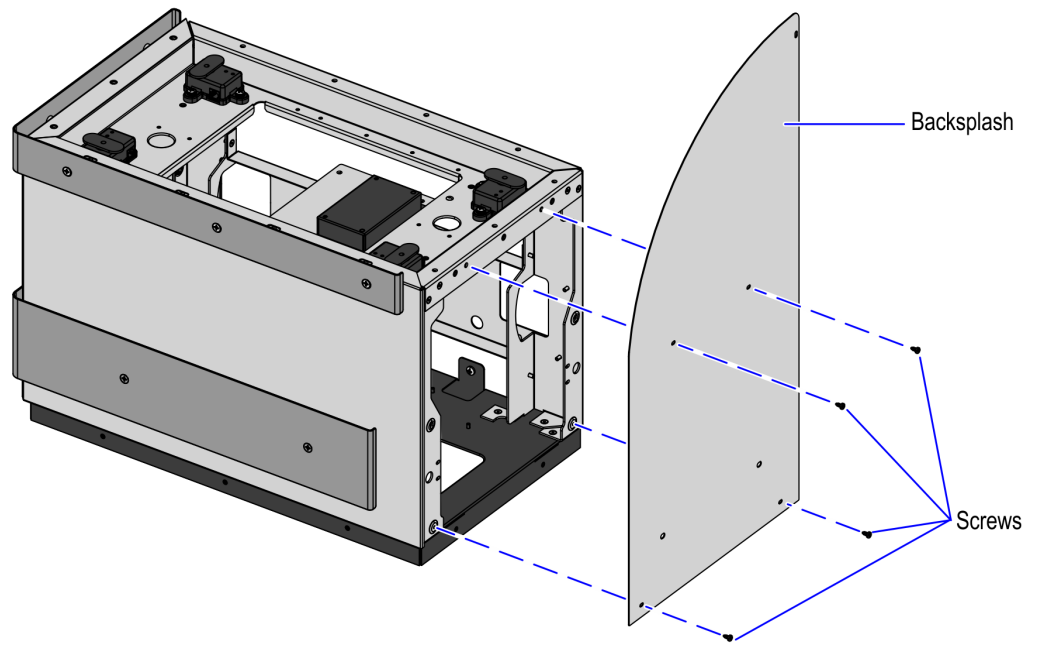

- c. Detach the upper bumper from the Bagwell by removing five (5) flat head screws and spacers, as shown in the image below.

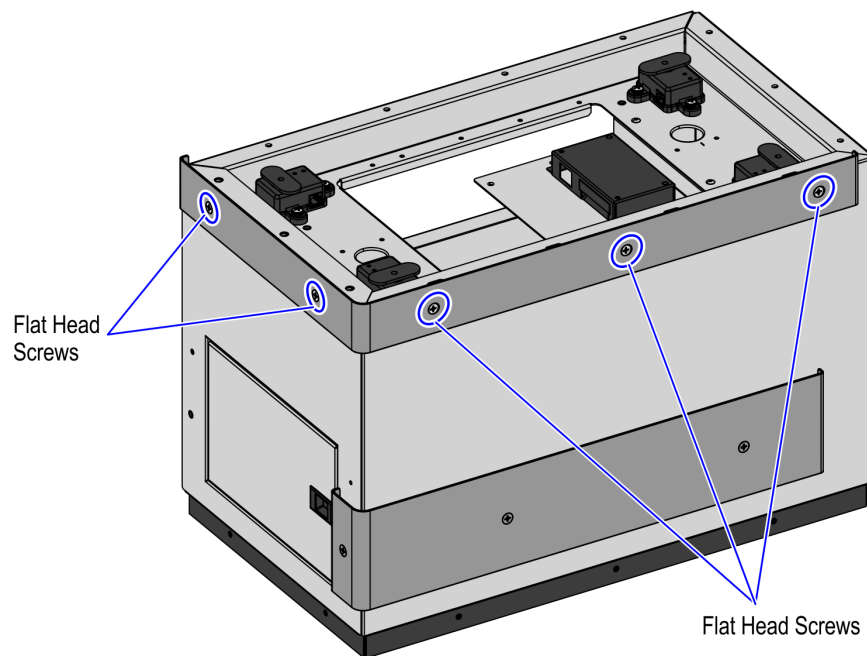

- d. Detach the wrap-around side bumper by removing three (3) flat head screws and spacers, as shown in the image below.

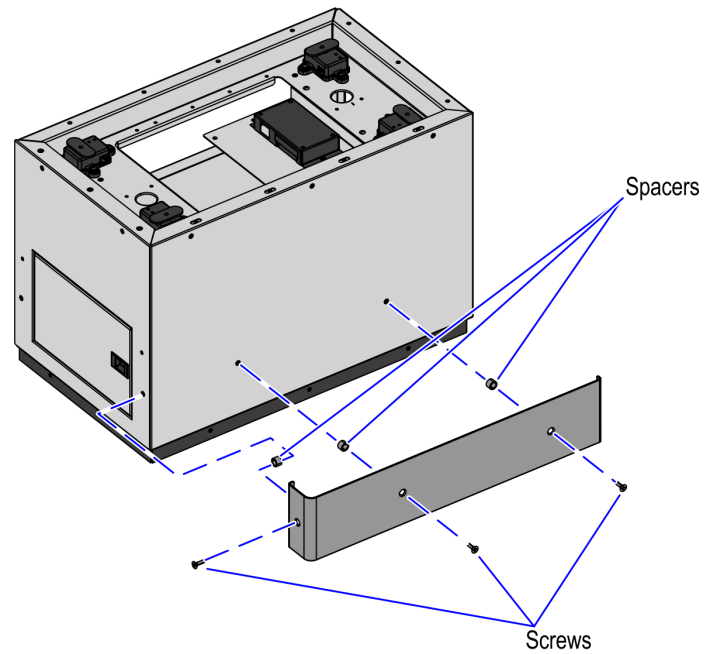

CCP-77322

3. Remove two (2) nuts securing the front panel to the Bagwell frame located at the inside corner posts.

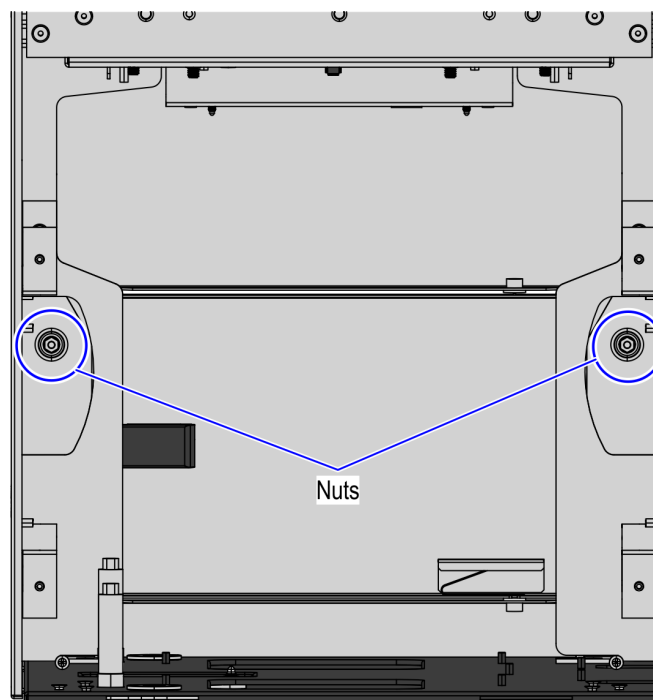

CCP-77323

4. Pull down the front panel and then pull out to disengage from the slots in the Bagwell frame base, as shown in the image below.

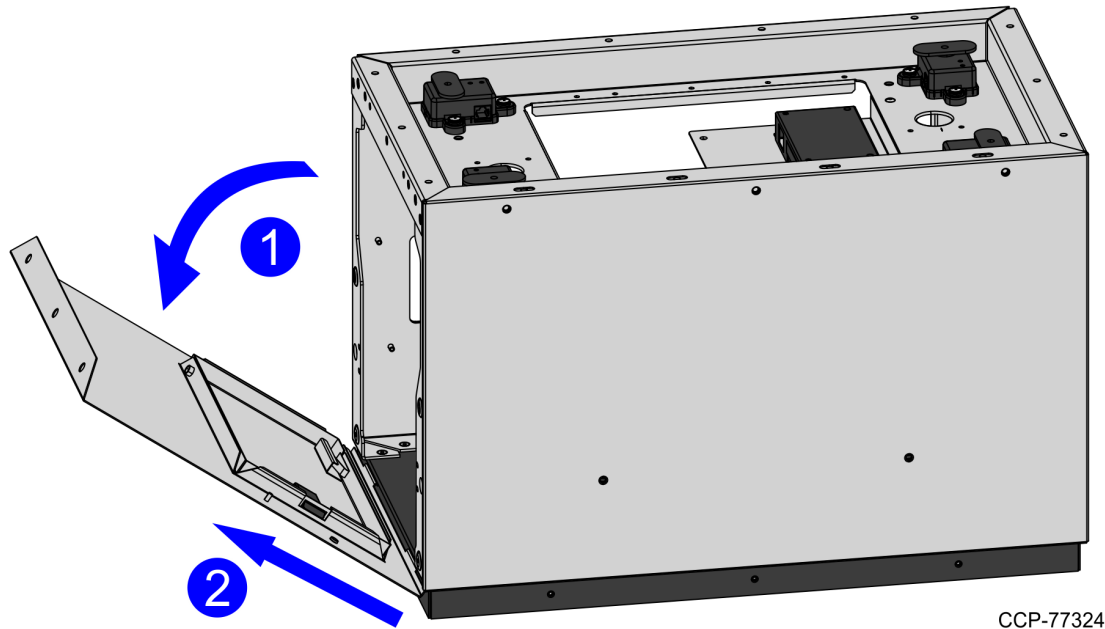

CCP-77324

5. Install the front panel on the opposite side of the Bagwell and secure it with two (2) nuts.



Note: Ensure that the lower hook features are properly aligned with the slots in the Bagwell frame base.

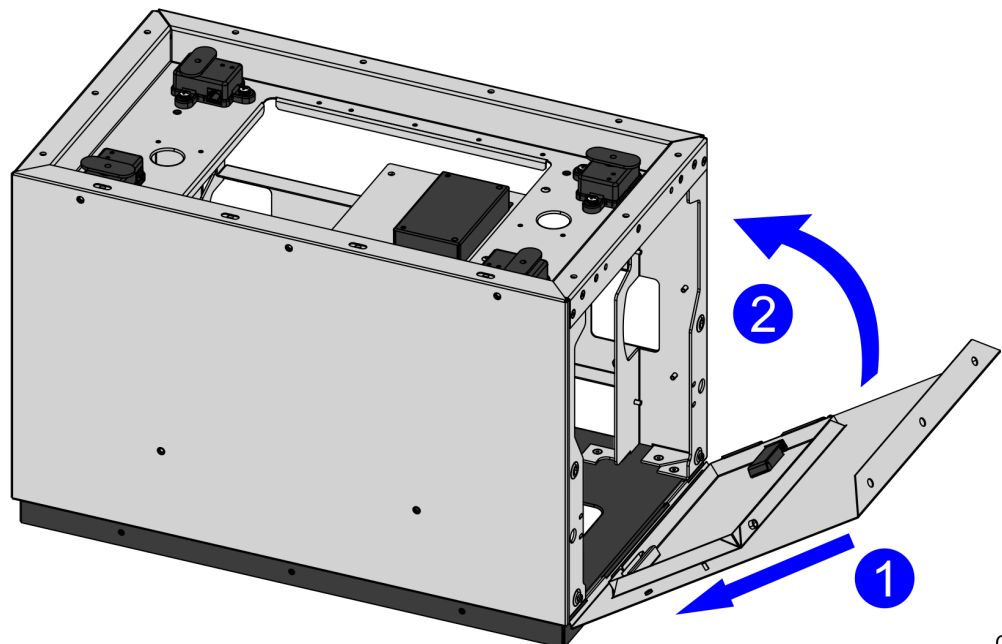

CCP-77325

6. Install the bumpers to the Bagwell by doing the following:



Note: Do not reinstall Scale Tray, Backsplash panel, and rear lower bumper (if present). For more information, refer to [Installing New Bagwell](#) on the next page.

- a. Attach the upper stainless steel bumper to the Bagwell by using five (5) flat head screws and spacers.

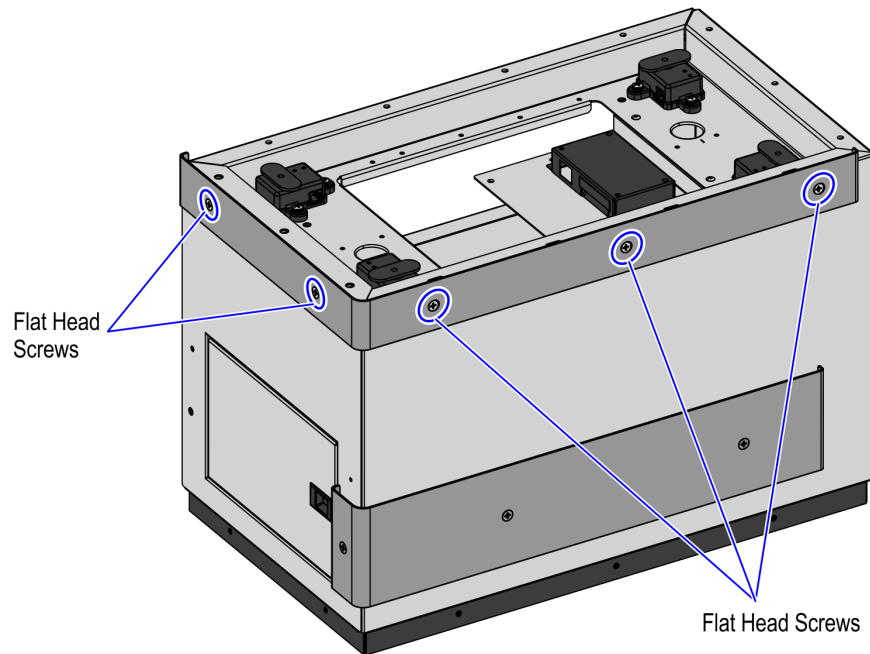

CCP-77321

- b. Attach the wrap-around bumper to the Bagwell by using three (3) flat head screws and spacers.

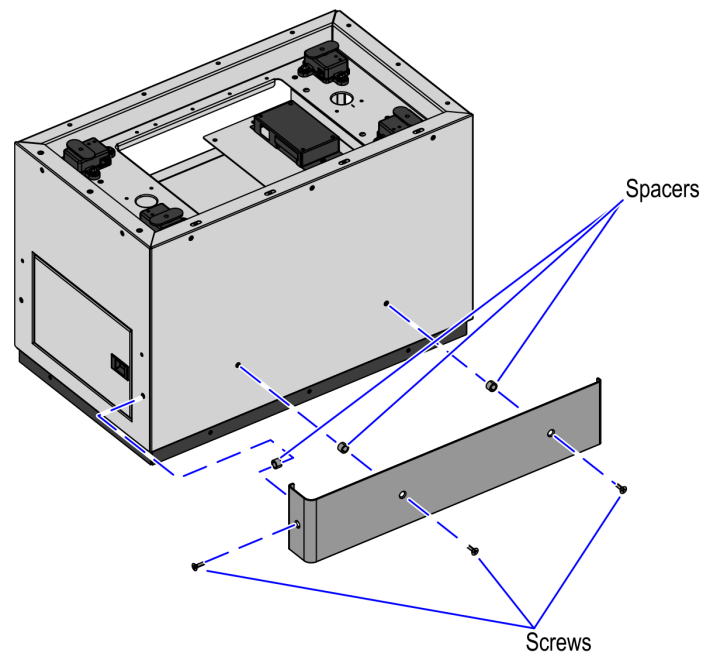

CCP-77322

Installing New Bagwell

To install the new Bagwell, follow these steps:



Note: If changing the Bagwell orientation (Left-Hand or Right-Hand), ensure that the orientation is changed before installing the new Bagwell to the Core. For the purpose of illustration only, this procedure shows images using a Left-hand (LH) orientation unit.

1. Remove the Scale Tray from the Bagwell.
2. Remove the lower access panel from the Core side where the new Bagwell will be attached. Reinstall the access panel on the opposite side of the Core.



Note: This panel does not need to be reinstalled when attaching a Bagwell to a No-Bag Unit.

Right-hand Configuration

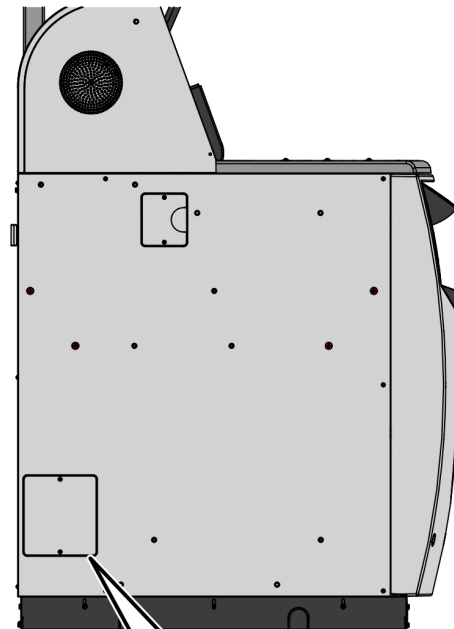

Lower Access Panel

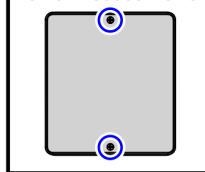

Left-hand Configuration

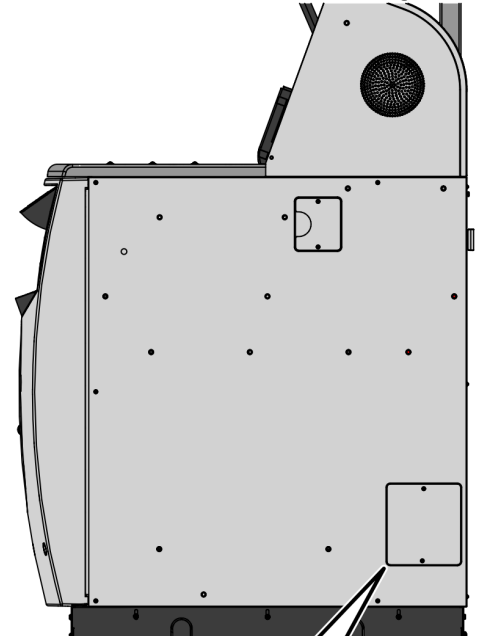

Lower Access Panel

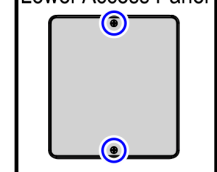

3. Lower all the leveling feet of the Bagwell slightly beyond the height of the casters to assist in lining up the Core and the Bagwell mounting holes.

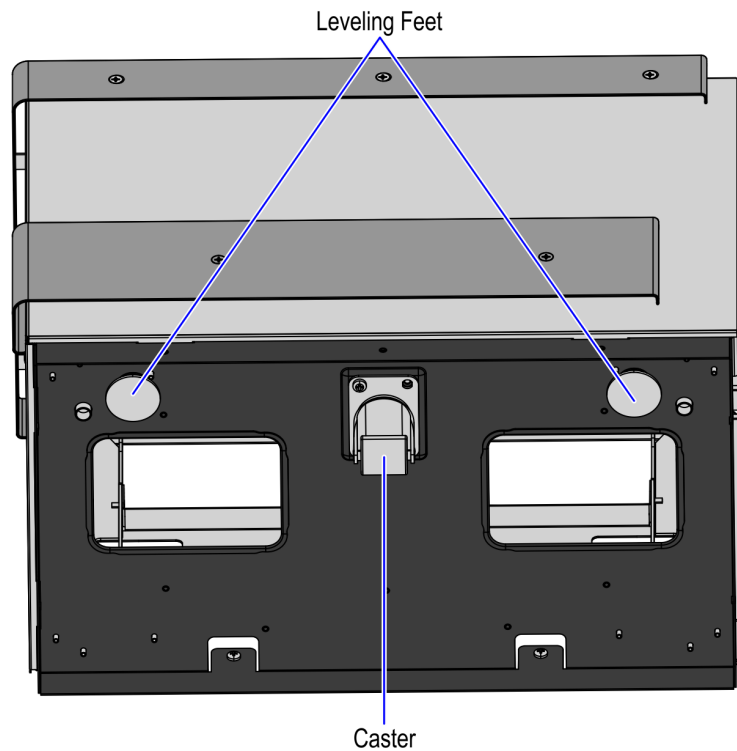

CCP-77327

4. Install the new Backsplash panel using four (4) screws, as shown in the image below.

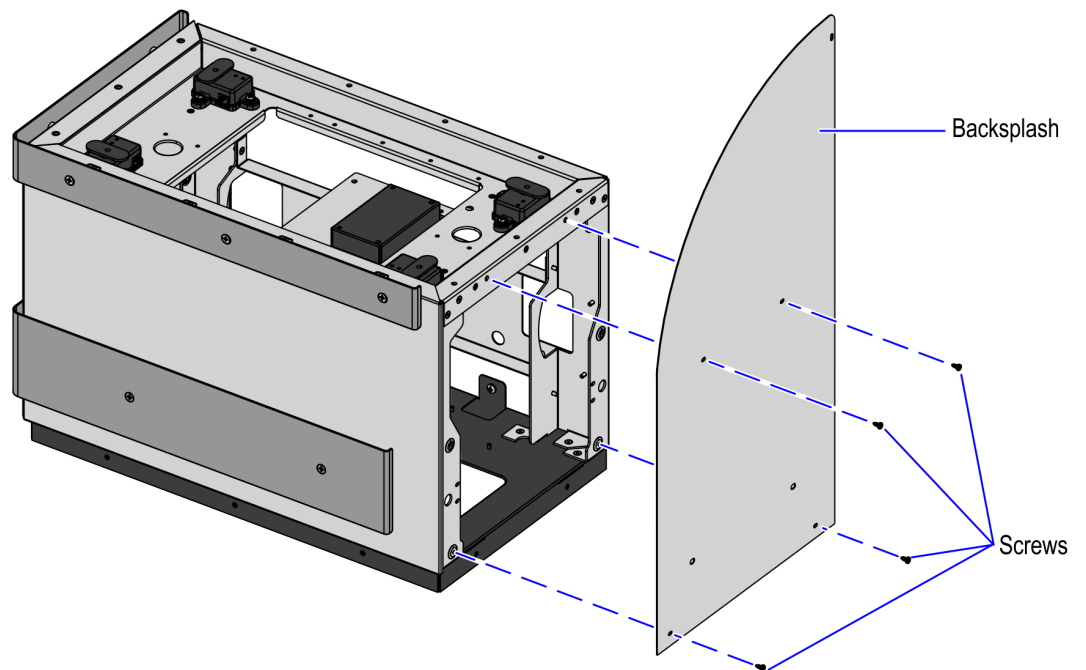

CCP-77320

5. If not already present, partially thread the two (2) upper screws on the Bagwell side of the Core. Leave approximately $\frac{1}{4}$ inch of the threads exposed.

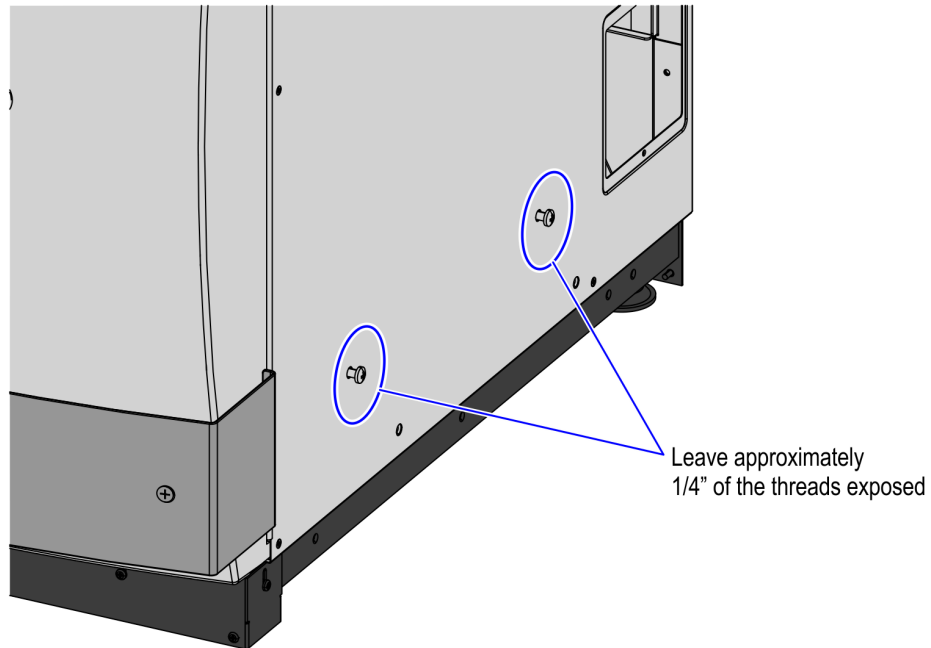

CCP-77329

6. Mate the new Bagwell to the Core by lifting the frame up and over the partially threaded screws.



Note: Ensure that the two frontmost key holes on the Bagwell are used.

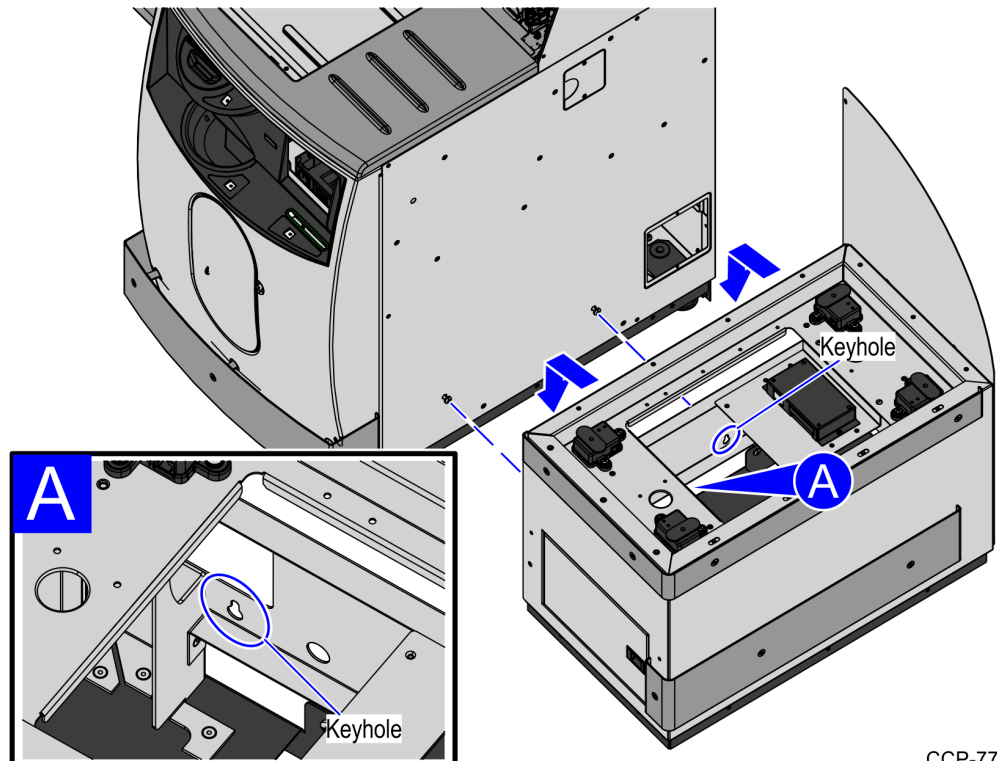

CCP-77330

7. Tighten the two (2) screws and install the two (2) lower screws that connect the Bagwell and the Core.

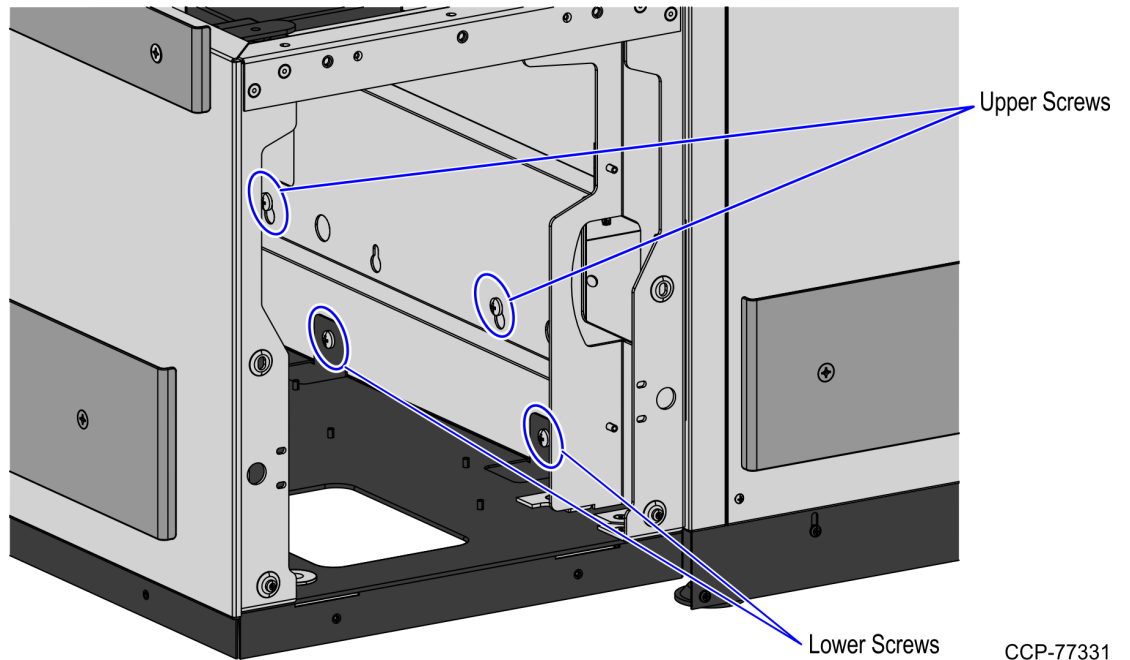

8. Install the upper rear screw attaching the Backsplash panel to the Core.



Note: Adjust the leveling feet if the slot does not line up well.

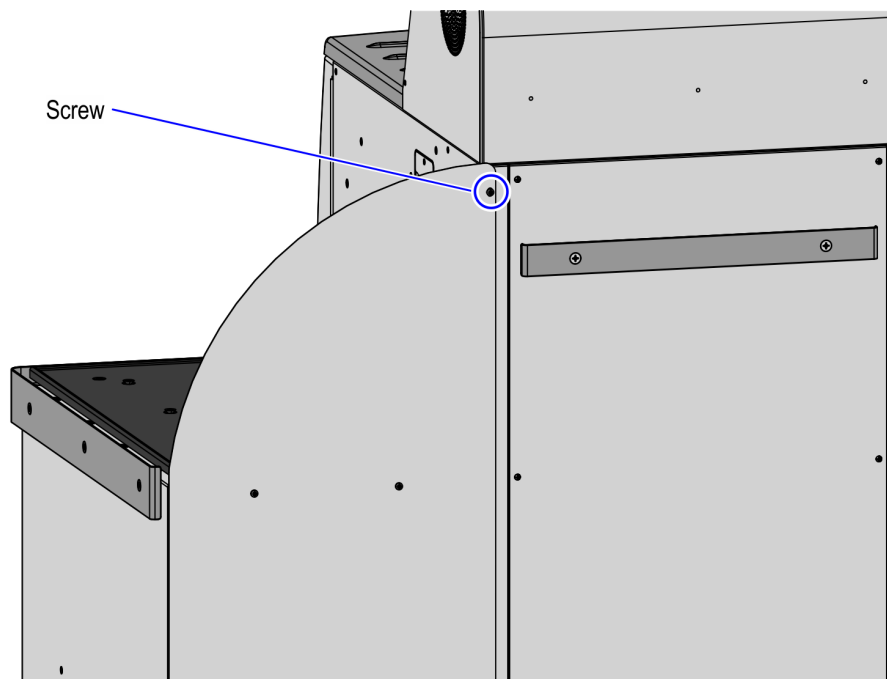

9. If present, install two rear lower bumpers using two (2) plastic spacers and two (2) flat head screws on the Backsplash.

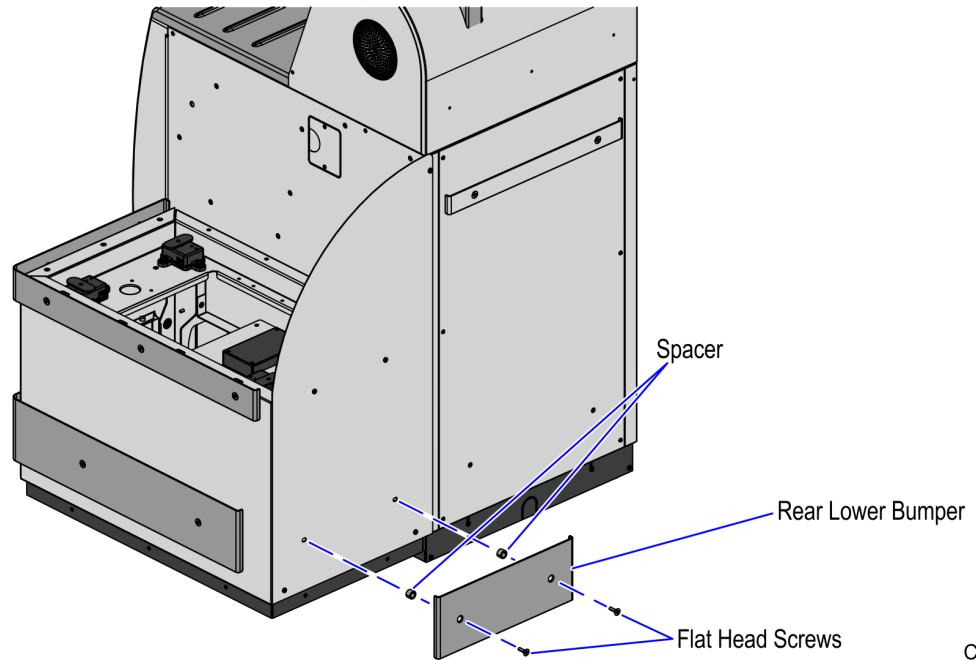

CCP-77332

10. Route the following cables through the cable access hole:

Bagwell Cable Access Hole

- AC Power In Cable

Core Cable Access Hole

- USB Power Cable
- Local Area Network (LAN) Cable
- AC Power Out Cables

For more information, refer to [Routing Cables](#) on page 25.

11. Remove four (4) yellow shipping spacers from the scale pods before installing the Scale Tray.

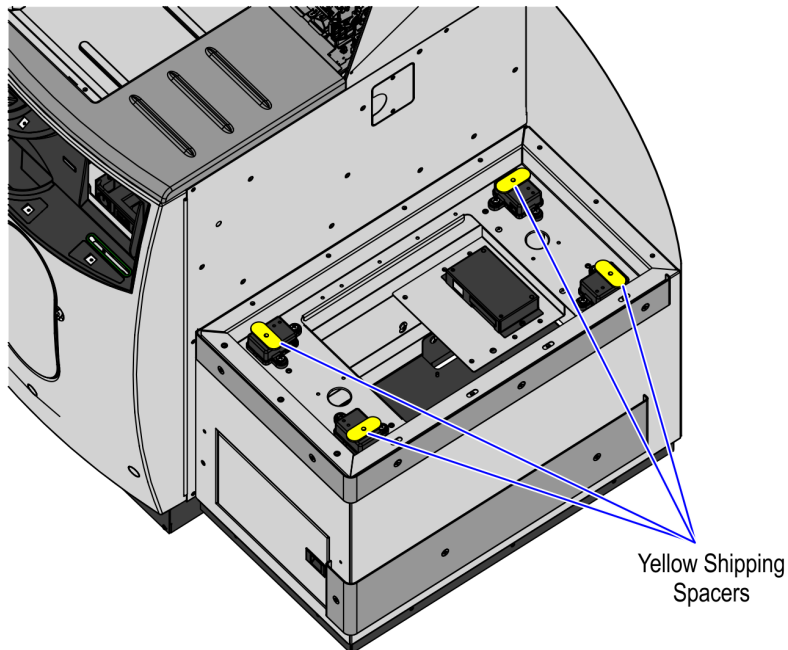

CCP-77333

12. Install the Scale Tray on the Bagwell using four (4) flat head screws.



Note: Ensure that the surface marked **BACK** is facing towards the back of the unit.

! Important: Use the correct screw length. Tighten the screws from six to eight pounds. **Do not overtighten** the screws to prevent inaccurate scale readings.

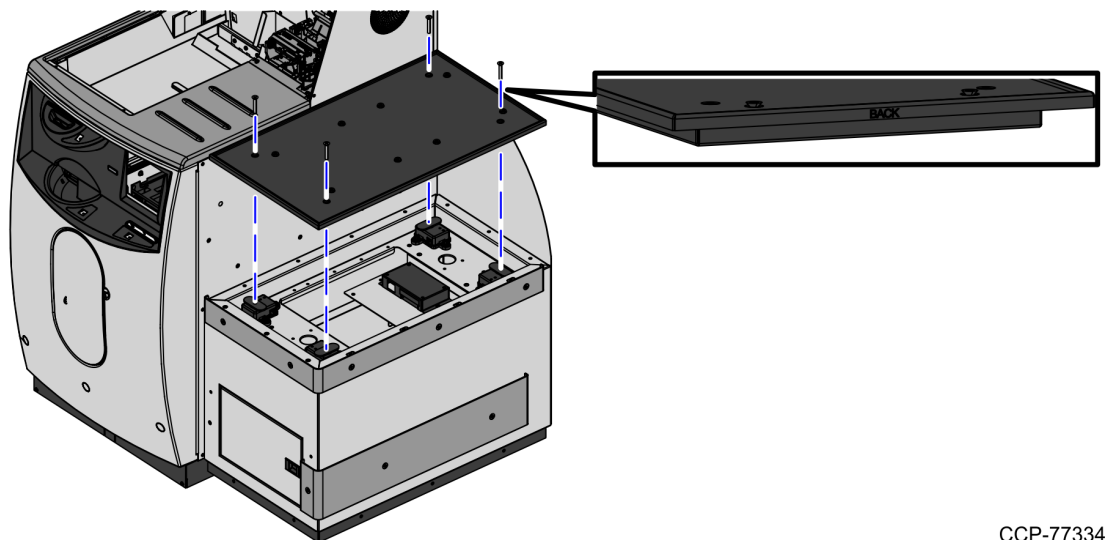

CCP-77334

13. Install clear plastic deflectors to the Core side and rear side of the Bagwell. Ensure that the deflectors meet at the rear and Core side corners, and should rest against the Bagwell frame.

! Important: Plastic deflectors must **not** touch the Scale Tray surface to avoid scale errors.

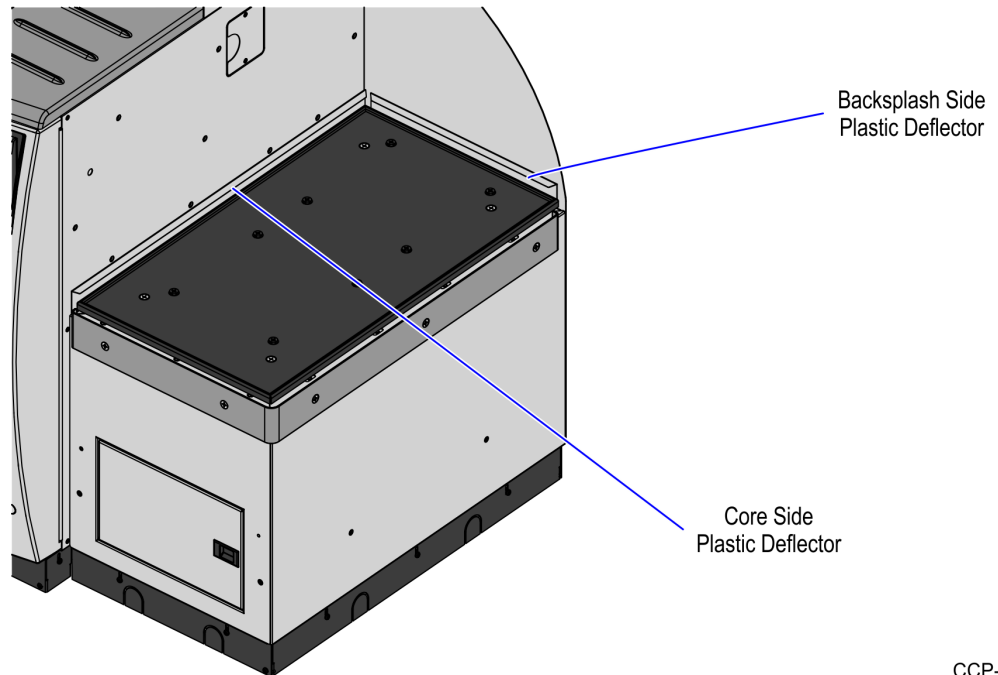

CCP-77312

14. Attach the Bagwell Skirt Panels. For more information, refer to [Installing Bagwell Skirt Panels](#) on the facing page.
15. Do the following:
 - Level the unit and attach the bag racks, if necessary. For more information, refer to the *NCR FastLane SelfServ™ Checkout (7358) R6L Plus Hardware Installation Guide (B005-0000-5263)*.
 - Test scale operation in PML. For more information, refer to the *NCR FastLane SelfServ™ Checkout Profile Manager Lite (PML) User Guide for ADD 3.X (B005-0000-2279)*.

Installing Bagwell Skirt Panels

To install Bagwell skirt panels, follow these steps:

1. On the side of the Bagwell, do the following:

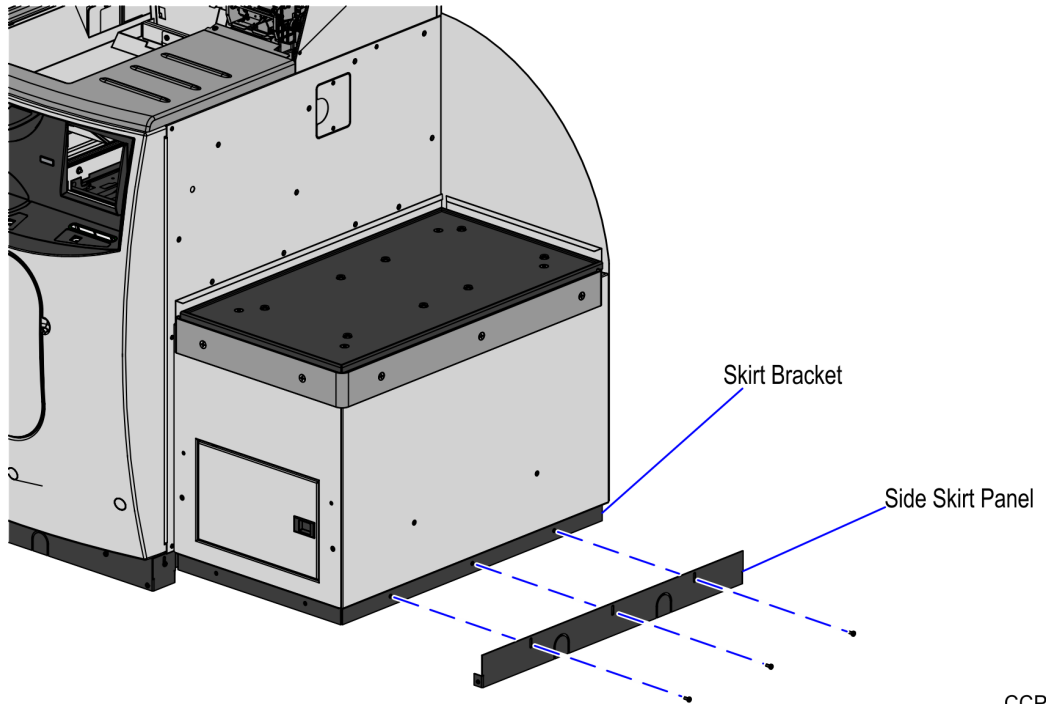

CCP-77309

- a. Attach the skirt panel to the skirt brackets by aligning the open slots in the skirt panel with the screw holes in the skirt bracket.
- b. Secure the skirt panel to the bracket using three (3) screws.
- c. Adjust the skirt panel so that it is flush with the floor.
- d. Tighten the screws to secure the skirt in place.

2. On the front and back of the Bagwell, do the following:



Note: The front and back skirt panels of the Bagwell must be installed after the side skirt panel of the Bagwell.

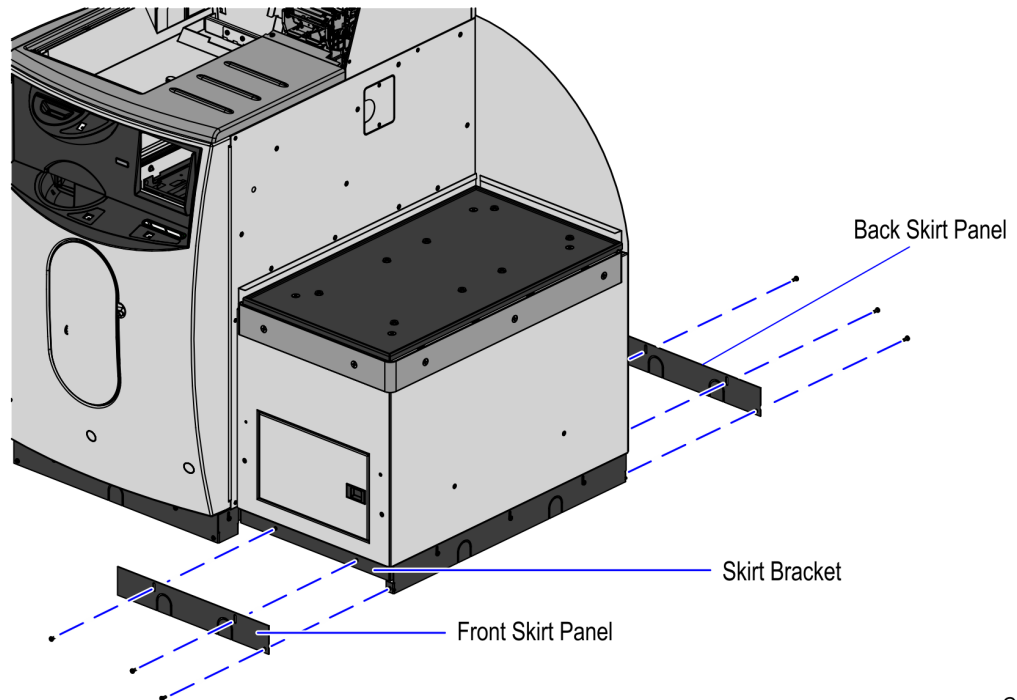

CCP-77310

- a. Attach each skirt panel to the skirt brackets by aligning the open slots in the skirt panel with the screw holes in the skirt bracket.
- b. Secure the skirt panels to the bracket using six (6) screws.
- c. Adjust the skirt panel so that it is flush with the floor.
- d. Tighten the screws to secure the skirt in place.

Routing Cables

To route cables when installing a new Bagwell, follow these steps:



Note: If a new Bagwell is installed to a No-Bag unit, refer to [Routing Cables for No-Bag unit](#) on page 28.



Note: Use the new pre-installed USB Power Cable only when installing a new Bagwell to a No-Bag unit. If not, reuse the existing USB Power Cable of the previous Bagwell.

1. Retrieve the USB Power Cable from the Core and route to the Scale Controller through the smaller opening of the Bagwell frame as shown in the image below.

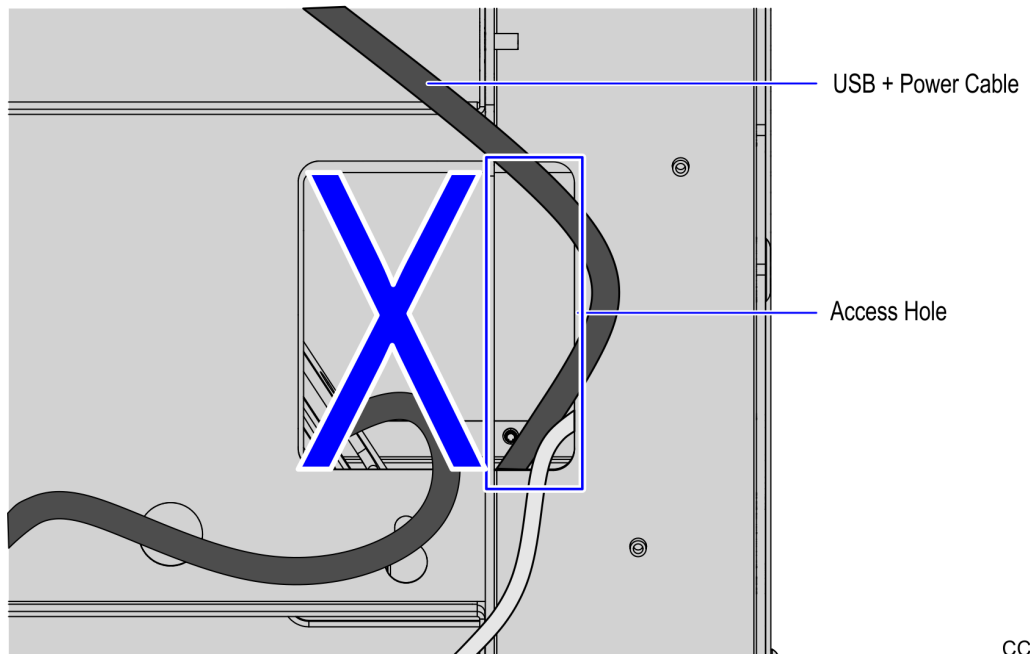

2. Tie the USB Power Cable with cable ties to hold it in place.

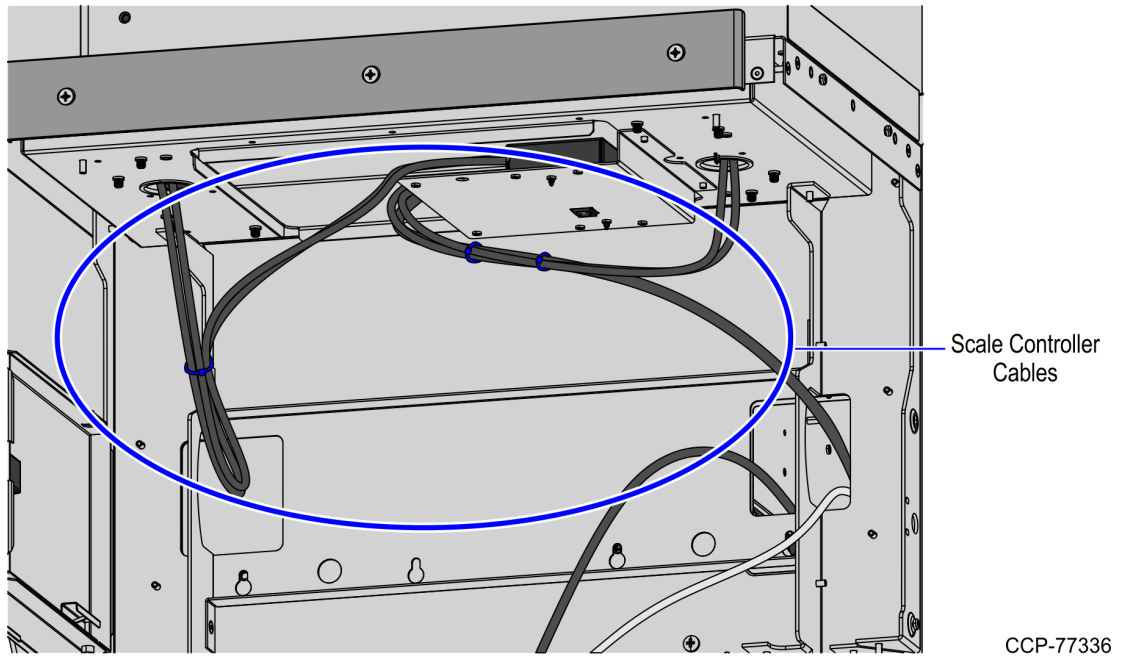

3. Route the Local Access Network (LAN) Cable from the Core to the Customer Interface through the smaller opening of the Bagwell frame as shown in the image below.

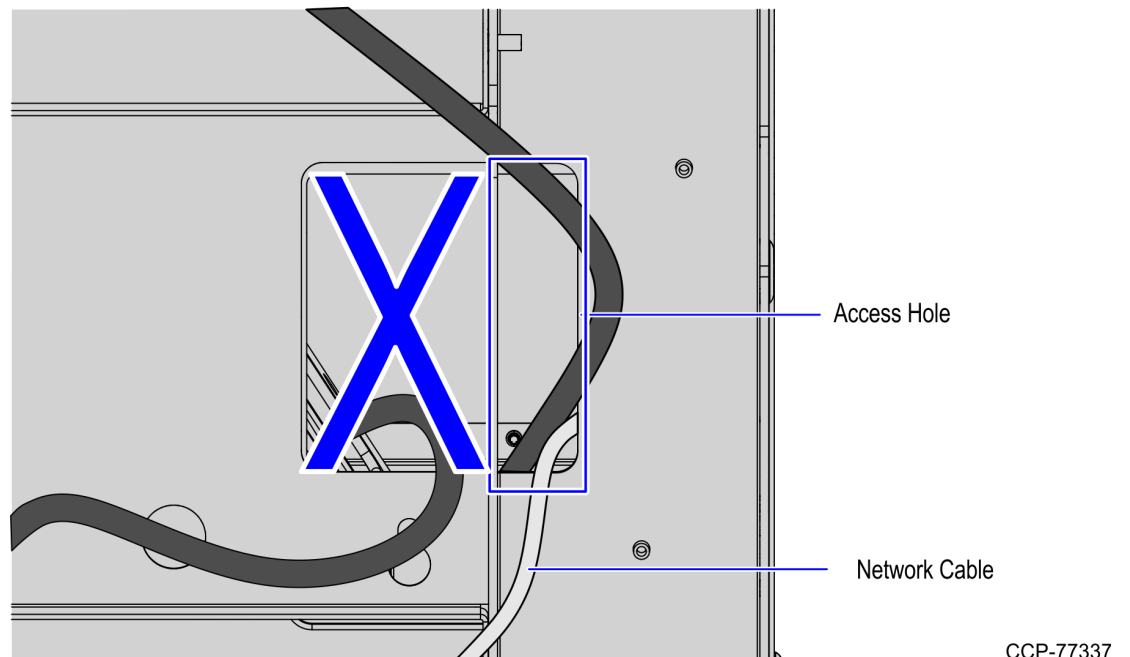

4. Route the AC Power Out and AC Power In cables and then connect to the Power Strip, as shown in the image below.

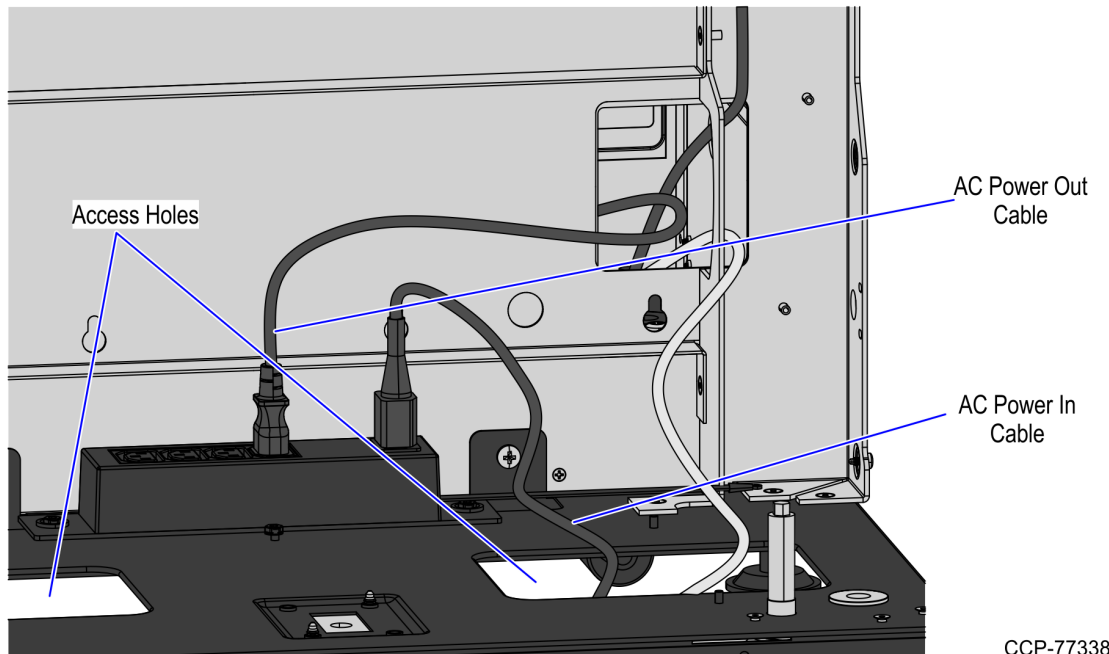

Routing Cables for No-Bag unit

These are additional steps in routing cables when upgrading a No-Bag unit to a 1-Bag unit:



Note: Use the new USB Power Cable. Route the USB Power Cable to the I/O Box first before installing new Bagwell.

1. Unlock and open the upper Cabinet Door.
2. Lift the Scale Plate from the Scanner.

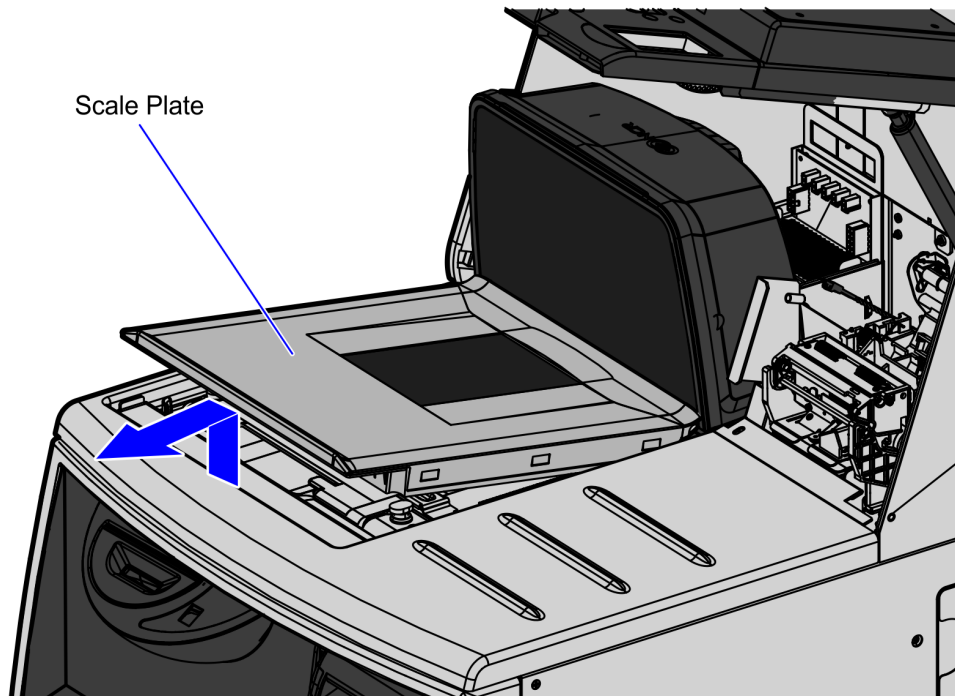

CCP-72727

3. Remove the Scanner/Scale by doing the following:
 - a. Grasp the front of the Scanner and lift up.
 - b. Grasp the back of the Scanner and slide the scanner out of the bucket area.

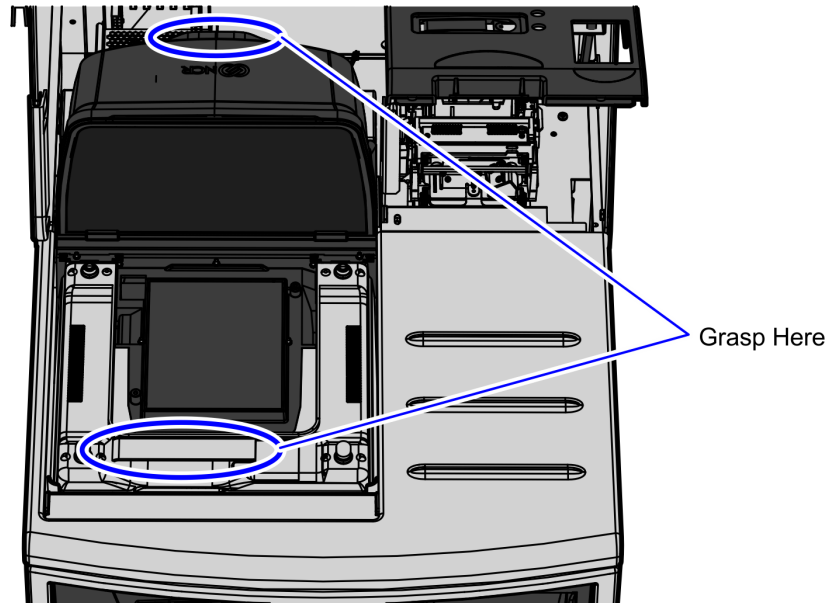

CCP-72728

4. Detach the rear Core panel by removing six (6) screws to access the main cable bundle and Power Strip.

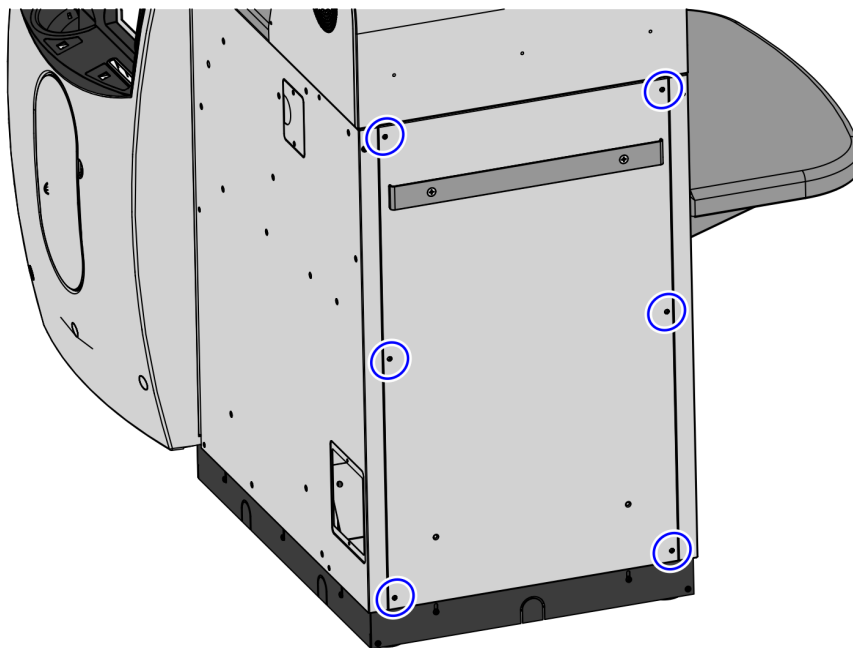

CCP-77769

5. Open the Tower Cabinet to access the I/O Box .
6. Unplug the pre-installed USB Power Cable from the Scale Controller in the new Bagwell and plug the host connector to USB G port of the I/O Box.
7. Route the cables along the cable guides, as shown in the image below. Ensure that the cable bundle is not in contact with the Tri-Light Pole Bracket.



Note: For more information about routing cables, refer to SCO Release 6 Lite Plus Cable Routing Instructions (497-0521474).

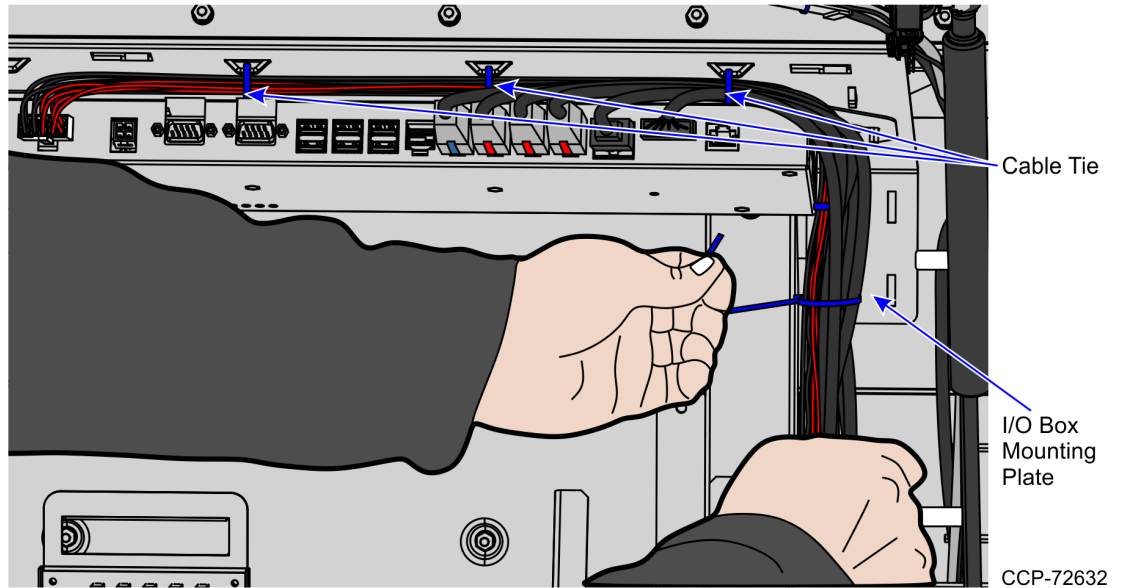

8. Install the Scanner/Scale by doing the following:
 - a. Grasp the Scanner/Scale by its handles and then lower it into the checkstand cutout.



Caution: Be careful not to damage any of the cables.

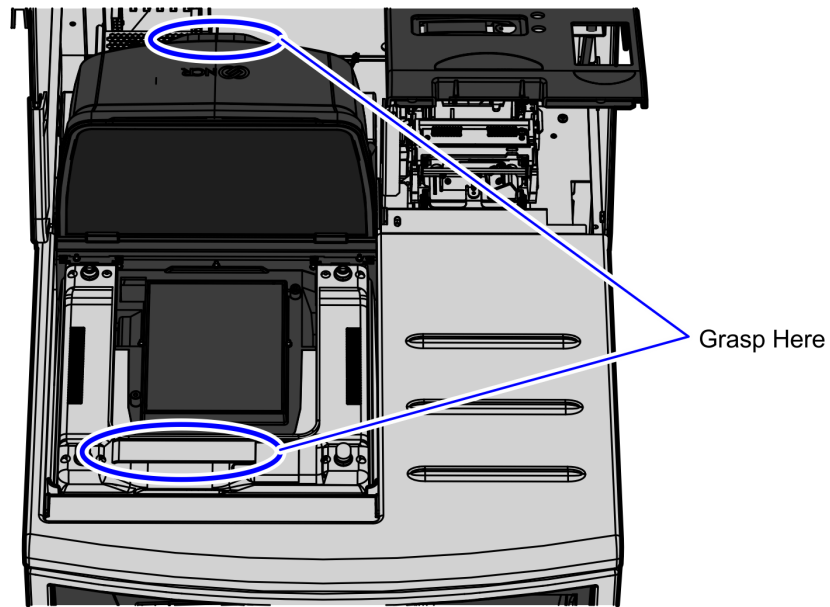

CCP-72728

- b. Lower the Scanner/Scale unto the scanner bucket area.
 - c. Install the Scale Plate by placing it on top of the load cells.

- Unplug the AC Power Out and AC Power In cables from the Power Strip. AC Power In Cable will be reused in the new Bagwell. AC Power Out Cable should be routed either through the left-hand or right-hand lower Core access cutout into the new Bagwell.



Note: The Power Strip remains on the rear Core wall but not reused.

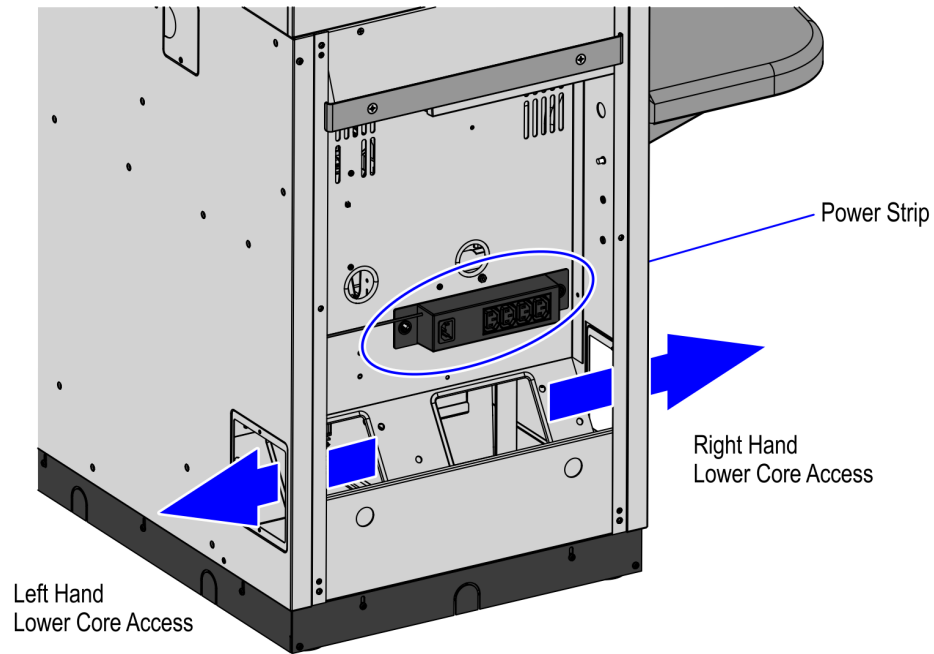

CCP-77348

- Finish routing the cables into the Bagwell. For more information, refer to [Routing Cables](#) on page 25.