

Kit Instructions

2-Bag Bagwell Upgrade

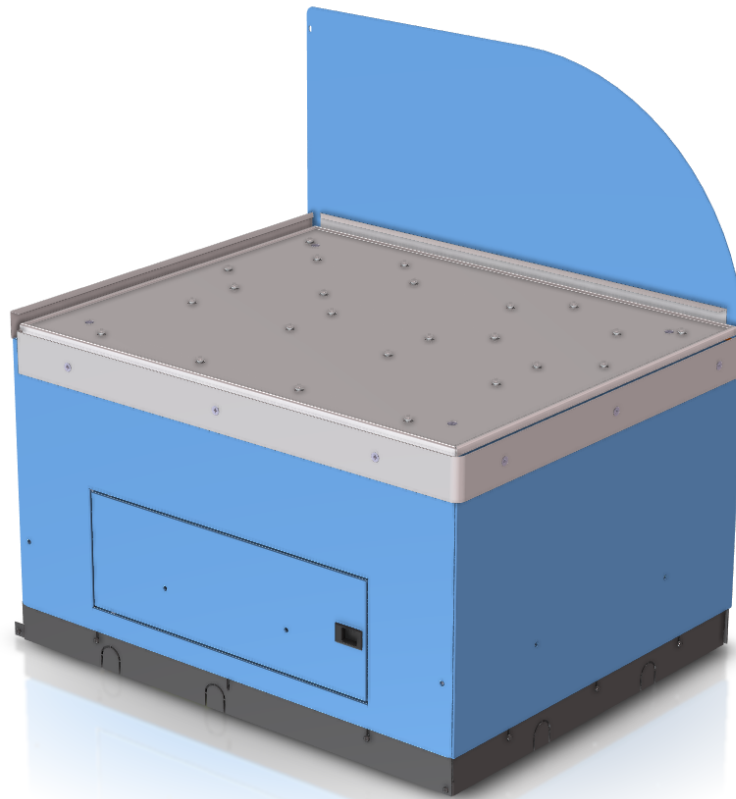

7350-K140/K141/K142/K143/K145/K964
Issue E



The product described in this document is a licensed product of NCR Corporation.

NCR is a registered trademark of NCR Corporation. NCR SelfServ™ Checkout is a trademark of NCR Corporation in the United States and/or other countries. Other product names mentioned in this publication may be trademarks or registered trademarks of their respective companies and are hereby acknowledged.

The terms HDMI and HDMI High-Definition Multimedia Interface, and the HDMI Logo are trademarks or registered trademarks of HDMI Licensing LLC in the United States and other countries.

Where creation of derivative works, modifications or copies of this NCR copyrighted documentation is permitted under the terms and conditions of an agreement you have with NCR, NCR's copyright notice must be included.

It is the policy of NCR Corporation (NCR) to improve products as new technology, components, software, and firmware become available. NCR, therefore, reserves the right to change specifications without prior notice.

All features, functions, and operations described herein may not be marketed by NCR in all parts of the world. In some instances, photographs are of equipment prototypes. Software screen images are representative, and in some cases, may not match a customer's installed software exactly. Therefore, before using this document, consult with your NCR representative or NCR office for information that is applicable and current.

Copyright © 2011-2021

By NCR Corporation

Global Headquarters

864 Spring St. NW

Atlanta, GA 30308

United States

All Rights Reserved

Revision Record

Issue	Date	Remarks
A	Jan 2011	<ul style="list-style-type: none">• First Issue• 50DR20059
B	Aug 2011	<ul style="list-style-type: none">• Added steps on the removal and installation of stainless steel lower bumpers if included in the kit.• Added steps on the removal and installation of the rear frame support bracket.• Added steps on the installation of the rear lower bumper on the Backsplash if included in the kit.• 50DR22474
C	July 2019	<ul style="list-style-type: none">• Added to IP Kit Repository site with HTML version.• 50DR36322
D	Aug 2019	<ul style="list-style-type: none">• Updated Kits• 50DR36505
E	Nov 2021	Updated Kit Contents

2-Bag Bagwell Upgrade

This publication provides procedures for installing a 2-Bag Bagwell to a 7350 NCR SelfServ™ Checkout.

Kit Contents

Depending on the color variant of the Bagwell, refer to the following sections for information about kit contents:

- [7350-K140 2-Bag Bagging Area \(G/11\)](#) on the next page.
- [7350-K141 2-Bag Bagging Area \(Battleship Gray\)](#) on page 4.
- [7350-K142 2-Bag Bagging Area \(Dark Red\)](#) on page 7.
- [7350-K143 2-Bag Bagging Area \(RAL 9001 Cream\)](#) on page 9.
- [7350-K145 2-Bag Bagging Area \(Walmart Blue\)](#) on page 11.
- [7350-K964 2-Bag Bagging Area \(RAL 7021 Black\)](#) on page 13.

7350-K140 2-Bag Bagging Area (G/11)

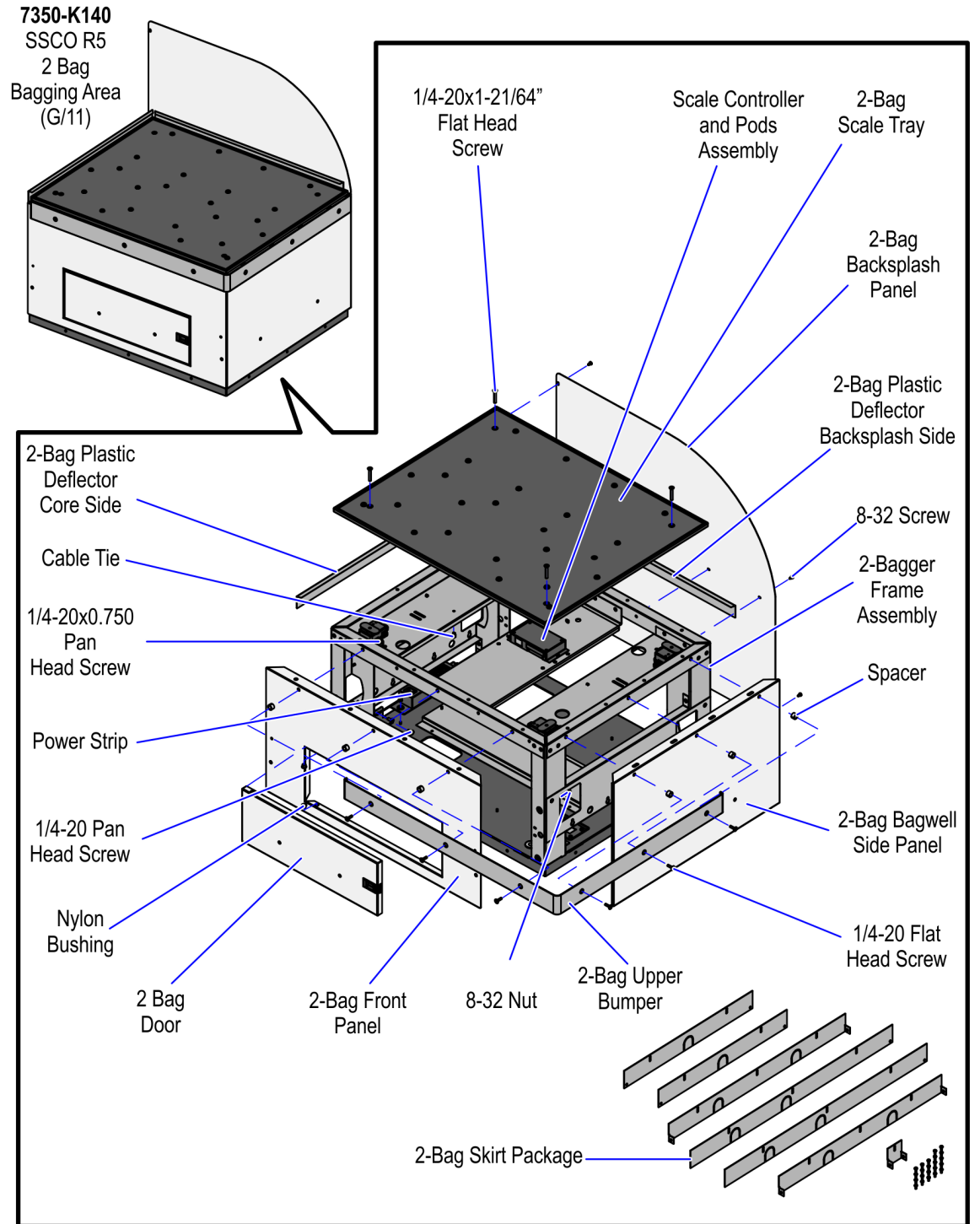

CCP-77351

Part Number	Description
497-0526236	2-Bag Bagging Area (G/11)

Part Number	Description
795-0283601	2-Bag Door Assembly (G/11)
795-0134201	2-Bag Backsplash Panel (G/11)
795-0134101	2-Bag Front Panel (G/11)
795-0133301	2-Bag Bagwell Side Panel (G/11)
006-8604541	Screw - 1/4-20x1/2, Pan Head, Phillips (4 pcs)
497-0472268	2-Bag Scale Tray with Bag Rack Hardware
497-0526950	Skirt - 2-Bag BOM Package
497-0528668	2-Bag Frame Assembly with Leveling Feet and Casters
497-0467814	Scale Controller and Pods Assembly
497-0457054	Black Nylon Spacer 15mm OD x 10.4mm ID x 10mm L (6 pcs)
497-0518273	2-Bag Upper Bumper
497-0455521	2-Bag Bagwell Backsplash Plastic Deflector
497-0455519	Core Side Plastic Deflector
006-8611143	Nut Keps, 8-32, Steel, Blue Zinc (5 pcs)
006-8611505	Nylon Bushing (2 pcs)
009-0005930	Cable Tie-snap in Mounting (3 pcs)
006-8623998	Screw - 1/4-20 x 1-21/64", Phillips Flat Head, 82 Degree, Machine Thread, Zinc-Plated Steel (4pcs)
006-8612492	Screw - 1/4-20 x 0.750", Phillips Flat Head, 82 Degree, Machine Thread, Zinc-Plated Steel (6 pcs)
006-8612446	Screw - 8-32 x 0.375" Phil Pan, Self Tapping - Type F (10 pcs)
006-8616060	Screw - 1/4-20 x 0.75", Pan Head, Phillips, Zinc Plated Steel (8 pcs)
* 795-0281699	Hole Cover Label - (G/11)
* 497-0445077	Cable: (Black) 4M USB +Power (12V) to 2x4 Latch-N-Lok
* 497-0426042	Bag - 2 and 3.5 Bagger, LHC and RHC, Input Belt
497-0421485	Power Strip, IEC 4-POS, Plastic Case
* 497-0513382	Multiple Power Sources/ Disconnect Power Caution Label
* 007-9714414	Tiestrap Plain 5.60LG (2pcs)
* 497-0423108	Kit Instructions (Reference Sheet)

* Items marked with an asterisk are not called out on the image.

7350-K141 2-Bag Bagging Area (Battleship Gray)

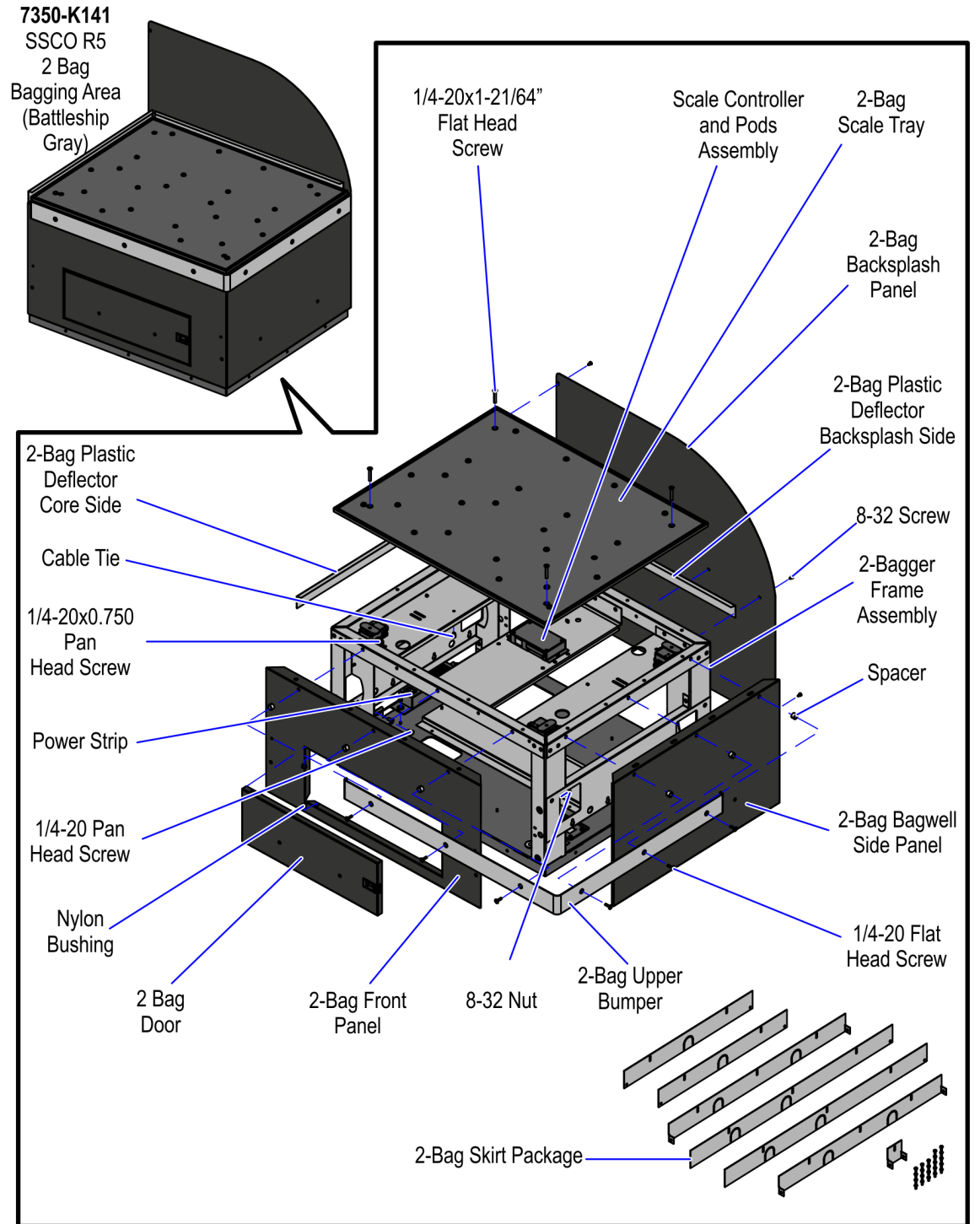

CCP-77352

Part Number	Description
497-0526239	2-Bag Bagging Area (Battleship Gray)

Part Number	Description
795-0283616	2-Bag Door Assembly (Battleship Gray)
795-0134216	2-Bag Backsplash Panel (Battleship Gray)
795-0134116	2-Bag Front Panel (Battleship Gray)
795-0133316	2-Bag Side Panel (Battleship Gray)
006-8604541	Screw - 1/4-20x1/2, Pan Head, Phillips (4pcs)
497-0472268	2-Bag Scale Tray with Bag Rack Hardware
009-0005930	Cable Tie-snap in Mounting (3 pcs)
497-0528668	2-Bag Frame Assembly with Leveling Feet and Casters
497-0467814	Scale Controller and Pods Assembly
497-0457054	Black Nylon Spacer 15mm OD x 10.4mm ID x 10mm L (6 pcs)
497-0518273	2-Bag Upper Bumper
497-0455521	2-Bag Bagwell Backsplash Plastic Deflector
497-0455519	Core Side Plastic Deflector
006-8611143	Nut Keps, 8-32, Steel, Blue Zinc (5 pcs)
006-8611505	Nylon Bushing (2 pcs)
497-0526950	Skirt - 2-Bag BOM Package
006-8623998	Screw - 1/4-20 x 1-21/64", Phillips Flat Head, 82 Degree, Machine Thread, Zinc-Plated Steel (4 pcs)
006-8612492	Screw - 1/4-20 x 0.750", Phillips Flat Head, 82 Degree, Machine Thread, Zinc-Plated Steel (6 pcs)
006-8612446	Screw - 8-32 x 0.375" Phil Pan, Self Tapping - Type F (10 pcs)
006-8616060	Screw - 1/4-20 x 0.75", Pan Head, Phillips, Zinc Plated Steel (8 pcs)
* 795-0281616	Hole Cover Label (Battleship Gray)
* 497-0445077	Cable: (Black) 4M USB +Power (12V) to 2x4 Latch-N-Lok
* 497-0426042	Bag - 2 and 3.5 Bagger, LHC and RHC, Input Belt
497-0421485	Power Strip, IEC 4-POS, Plastic Case
* 497-0513382	Multiple Power Sources/ Disconnect Power Caution Label
497-0518274	2-Bag Rear Door Bumper

Part Number	Description
497-0518276	2-Bag Core Side Lower Back Bumper
497-0518277	2-Bag Wrap-Around Side Corner Bumper
497-0455678	2-Bag Rear Frame Support Bracket (3 pcs)
* 497-0423108	Kit Instructions (Reference Sheet)

* Items marked with an asterisk are not called out on the image.

7350-K142 2-Bag Bagging Area (Dark Red)

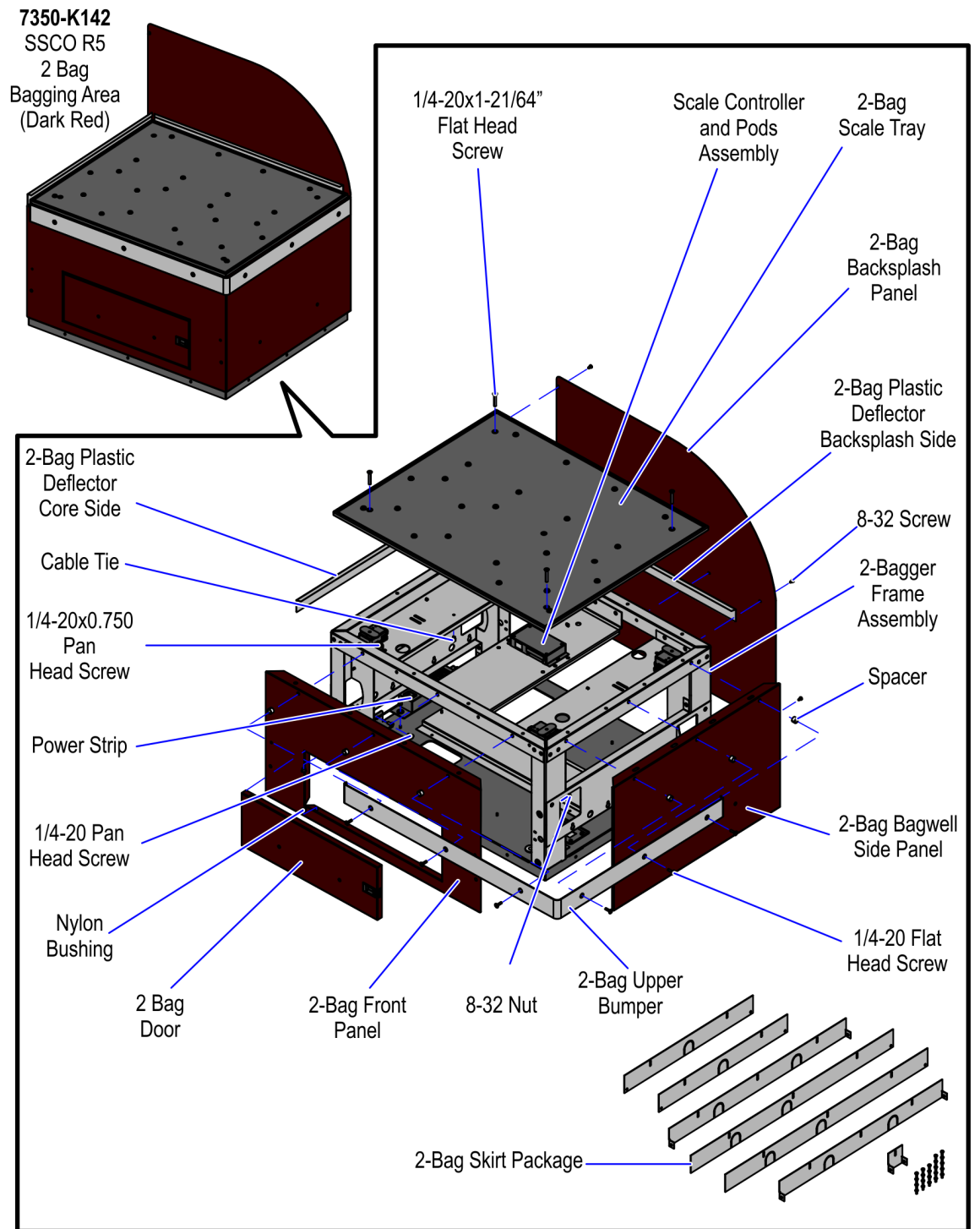

CCP-77353

Part Number	Description
497-0526240	2-Bag Bagging Area (Dark Red)

Part Number	Description
795-0283618	2-Bag Door Assembly (Dark Red)
795-0134218	2-Bag Backsplash Panel (Dark Red)
795-0134118	2-Bag Front Panel (Dark Red)
795-0133318	2-Bag Bagwell Side Panel (Dark Red)
* 795-0281618	Hole Cover Label (Dark Red)
006-8604541	Screw, 1/4-20x1/2, Pan Head, Phillips (4pcs)
497-0457054	Black Nylon Spacer 15mm OD x 10.4mm ID x 10mm L (6pcs)
497-0525620	2-Bag Frame Assembly with Leveling Feet and Casters
497-0466205	Skirt - 2 Bag BOM Package
497-0467814	Scale Controller and Pods Assembly
497-0472268	2-Bag Scale Tray with Bag Rack Hardware
006-8611143	Nut Keps, 8-32, Steel, Blue Zinc (5pcs)
006-8611505	Nylon Bushing (2pcs)
497-0455519	Core Side Plastic Deflector
497-0455521	2-Bag Bagwell Backsplash Plastic Deflector
497-0518273	2-BagUpper Bumper
009-0005930	Cable Tie-snap in Mounting (3pcs)
006-8612446	Screw - 8-32 x 0.375" Phil Pan, Self Tapping - Type F (10pcs)
006-8612492	Screw - 1/4-20 x 0.750", Phillips Flat Head, 82 Degree, Machine Thread, Zinc-Plated Steel (6pcs)
006-8616060	Screw - 1/4-20 x 0.75", Pan Head, Phillips, Zinc Plated Steel (8pcs)
006-8623998	Screw - 1/4-20 x 1-21/64", Phillips Flat Head, 82 Degree, Machine Thread, Zinc-Plated Steel (4pcs)
497-0421485	Power Strip, IEC 4-POS, Plastic Case
* 497-0426042	Bag - 2 and 3.5 Bagger, LHC and RHC, Input Belt
* 497-0445077	Cable: (Black) 4M USB +Power (12V) to 2x4 Latch-N-Lok
* 007-9714414	Tiestrap Plain 5.60LG (2pcs)
* 497-0513382	Multiple Power Sources/ Disconnect Power Caution Label
* 497-0423108	Kit Instructions (Reference Sheet)

* Items marked with an asterisk are not called out on the image.

7350-K143 2-Bag Bagging Area (RAL 9001 Cream)

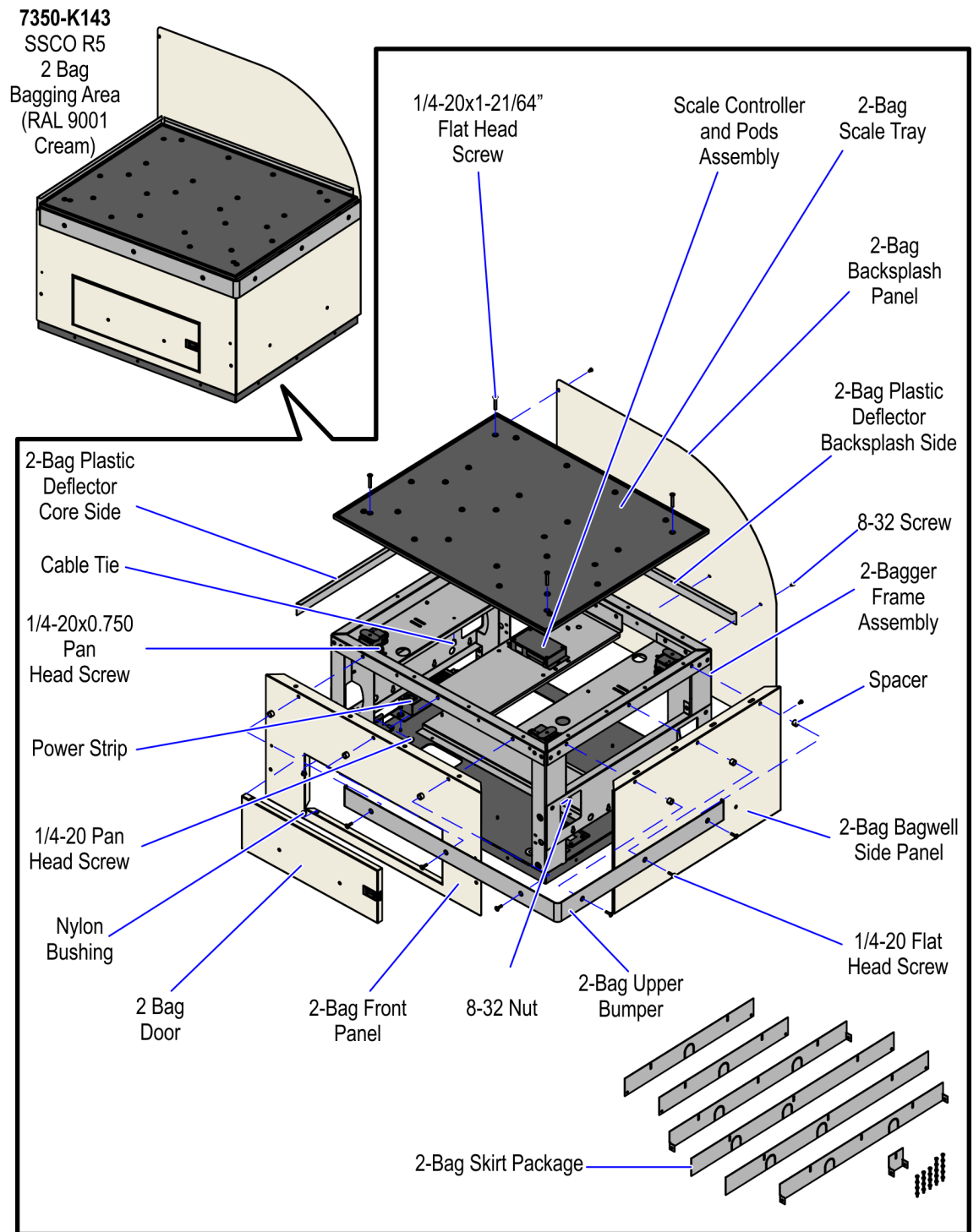

CCP-77354

Part Number	Description
497-0526238	2-Bag Bagging Area (RAL 9001 Cream)

Part Number	Description
795-0283609	2-Bag Door Assembly (RAL 9001 Cream)
795-0134209	2-Bag Backsplash Panel (RAL 9001 Cream)
795-0134109	2-Bag Front Panel (RAL 9001 Cream)
795-0133309	2-Bag Bagwell Side Panel(RAL 9001 Cream)
006-8604541	Screw -1/4-20x1/2, Pan Head, Phillips (4 pcs)
497-0472268	2-Bag Scale Tray with Bag Rack Hardware
497-0526950	Skirt - 2-Bag BOM Package
497-0528668	2-Bag Frame Assembly with Leveling Feet and Casters
497-0467814	Scale Controller and Pods Assembly
497-0457054	Black Nylon Spacer 15mm OD x 10.4mm ID x 10mm L (6 pcs)
497-0518273	2-Bag Upper Bumper
497-0455521	2-Bag Bagwell Backsplash Plastic Deflector
497-0455519	Core Side Plastic Deflector
006-8611143	Nut Keps, 8-32, Steel, Blue Zinc (5 pcs)
006-8611505	Nylon Bushing (2 pcs)
009-0005930	Cable Tie-snap in Mounting (3 pcs)
006-8623998	Screw - 1/4-20 x 1-21/64", Phillips Flat Head, 82 Degree, Machine Thread, Zinc-Plated Steel (4 pcs)
006-8612492	Screw - 1/4-20 x 0.750", Phillips Flat Head, 82 Degree, Machine Thread, Zinc-Plated Steel (6 pcs)
006-8612446	Screw - 8-32 x 0.375" Phil Pan, Self Tapping - Type F (10 pcs)
006-8616060	Screw - 1/4-20 x 0.75", Pan Head, Phillips, Zinc Plated Steel (8 pcs)
* 795-0281609	Hole Cover Label (RAL 9001 Cream)
* 497-0445077	Cable: (Black) 4M USB +Power (12V) to 2x4 Latch-N-Lok
* 497-0426042	Bag - 2 and 3.5 Bagger, LHC and RHC, Input Belt
497-0421485	Power Strip, IEC 4-POS, Plastic Case
* 497-0513382	Multiple Power Sources/ Disconnect Power Caution Label
* 007-9714414	Tiestrap Plain 5.60LG (2pcs)
* 497-0423108	Kit Instructions (Reference Sheet)

* Items marked with an asterisk are not called out on the image.

7350-K145 2-Bag Bagging Area (Walmart Blue)

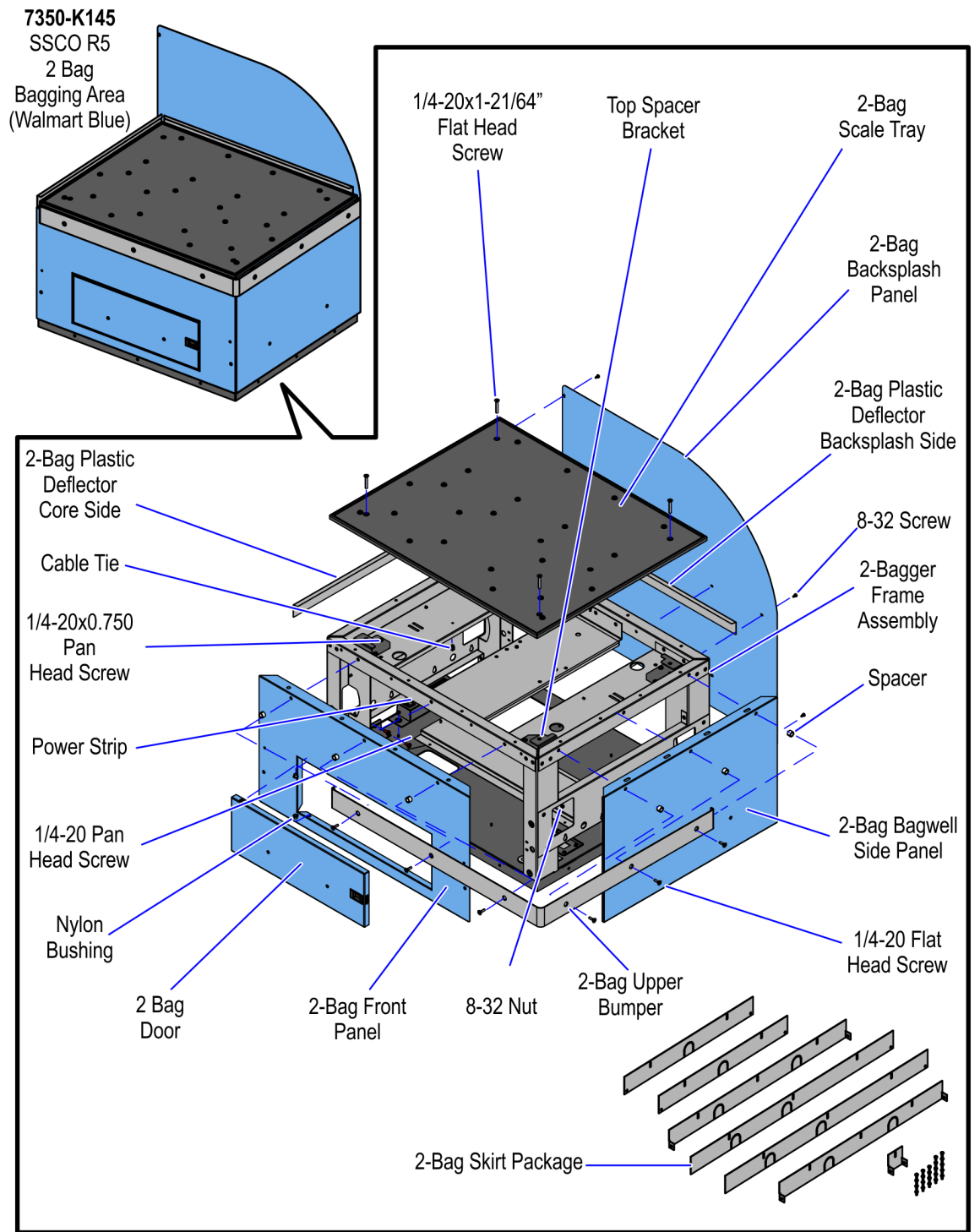

CCP-77355

Part Number	Description
497-0526496	2-Bag Bagging Area (Walmart Blue)

Part Number	Description
795-0283612	2-Bag Door Assembly (Walmart Blue)
795-0134212	2-Bag Backsplash Panel (Walmart Blue)
795-0134112	2-Bag Front Panel (Walmart Blue)
795-0133312	2-Bag Bagwell Side Panel (Walmart Blue)
* 795-0281612	Hole Cover Label (Walmart Blue)
006-8604541	Screw - 1/4-20x1/2, Pan Head, Phillips (4pcs)
497-0525620	2-Bag Frame Assembly with Leveling Feet and Casters
497-0466205	Skirt - 2-Bag BOM Package
497-0472268	2-Bag Scale Tray with Bag Rack Hardware
006-8611143	Nut Keps, 8-32, Steel, Blue Zinc (5pcs)
006-8611505	Nylon Bushing (2pcs)
497-0455519	Core Side Plastic Deflector
497-0455521	2-Bag Bagwell Backsplash Plastic Deflector
009-0005930	Cable Tie-snap in Mounting (3pcs)
006-8612446	Screw - 8-32 x 0.375" Phil Pan, Self Tapping - Type F (14pcs)
006-8616060	Screw - 1/4-20 x 0.75", Pan Head, Phillips, Zinc Plated Steel (8pcs)
006-8623998	Screw - 1/4-20 x 1-21/64", Phillips Flat Head, 82 Degree, Machine Thread, Zinc-Plated Steel (4pcs)
497-0421485	Power Strip, IEC 4-POS, Plastic Case
* 497-0426042	Bag - 2 AND 3.5 Bagger, LHC and RHC, Input Belt
* 007-9714414	Tiestrap Plain 5.60LG (2pcs)
* 497-0513382	Multiple Power Sources/ Disconnect Power Caution Label
497-0521432	Top Spacer Bracket (4pcs)
* 497-0423108	Kit Instructions (Reference Sheet)

* Items marked with an asterisk are not called out on the image.

7350-K964 2-Bag Bagging Area (RAL 7021 Black)

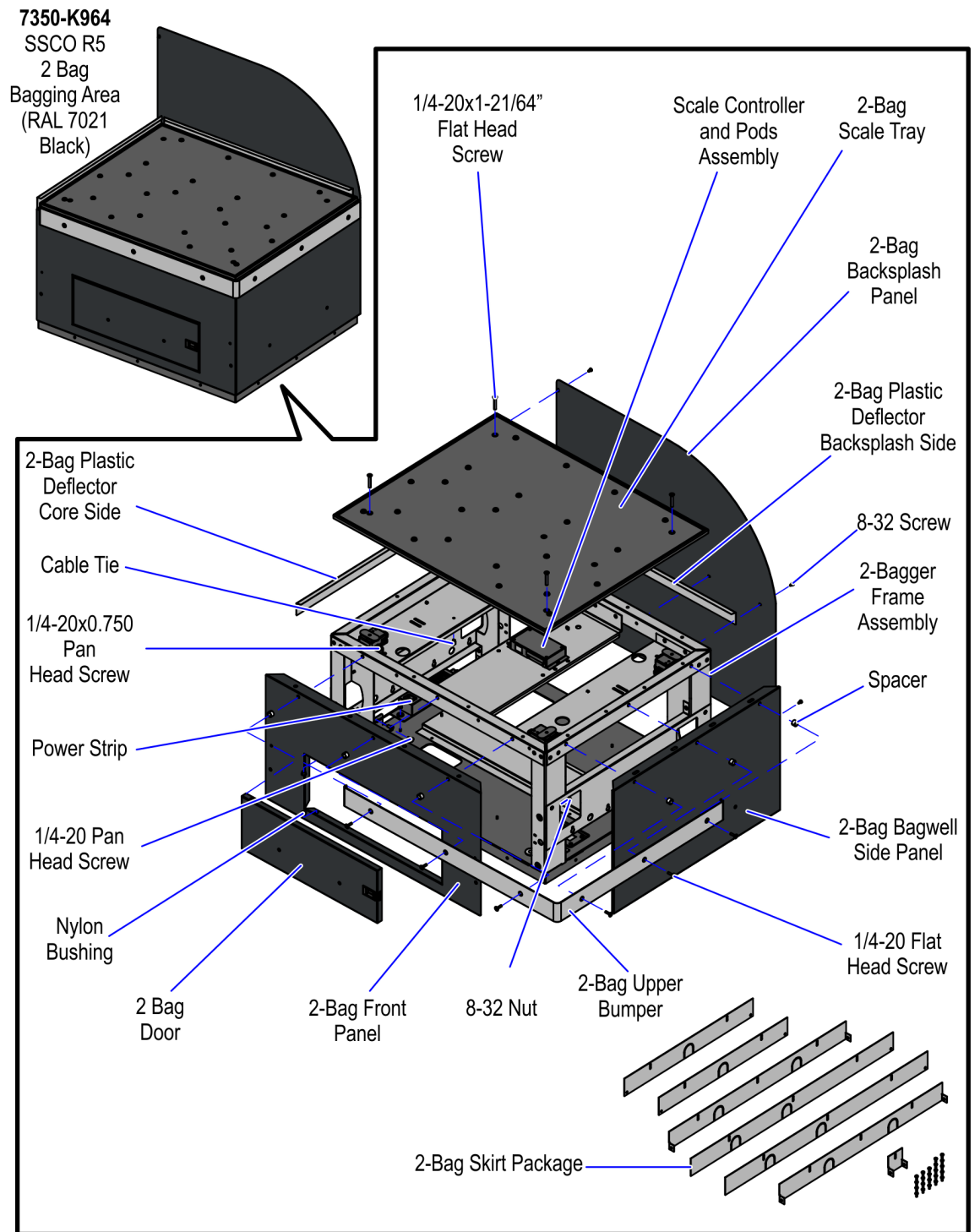

CCP-77356

Part Number	Description
497-0526237	2-Bag Bagging Area (RAL 7021 Black)

Part Number	Description
795-0283607	2-Bag Door Assembly (RAL 7021 Black)
795-0134207	2-Bag Backsplash Panel (RAL 7021 Black)
795-0134107	2-Bag Front Panel (RAL 7021 Black)
795-0133307	2-Bag Bagwell Side Panel (RAL 7021 Black)
006-8604541	Screw - 1/4-20x1/2, Pan Head, Phillips (4 pcs)
497-0472268	2-Bag Scale Tray with Bag Rack Hardware
497-0526950	Skirt - 2-Bag BOM Package
497-0528668	2-Bag Frame Assembly with Leveling Feet and Casters
497-0467814	Scale Controller and Pods Assembly
497-0457054	Black Nylon Spacer 15mm OD x 10.4mm ID x 10mm L (6pcs)
497-0518273	2-Bag Upper Bumper
497-0455521	2-Bag Bagwell Backsplash Plastic Deflector
497-0455519	Core Side Plastic Deflector
006-8611143	Nit Keps, 8-32, Steel, Blue Zinc (5 pcs)
006-8611505	Nylon Bushing (2 pcs)
009-0005930	Cable Tie-snap in Mounting (3 pcs)
006-8623998	Screw - 1/4-20 x 1-21/64", Phillips Flat Head, 82 Degree, Machine Thread, Zinc-Plated Steel (4 pcs)
006-8612492	Screw - 1/4-20 x 0.750", Phillips Flat Head, 82 Degree, Machine Thread, Zinc-Plated Steel (6 pcs)
006-8612446	Screw - 8-32 x 0.375" Phil Pan, Self Tapping - Type F (10 pcs)
006-8616060	Screw - 1/4-20 x 0.75", Pan Head, Phillips, Zinc Plated Steel (8 pcs)
* 795-0281607	Hole Cover Label (RAL 7021 Black)
* 497-0445077	Cable: (Black) 4M USB +Power (12V) to 2x4 Latch-N-Lok
* 497-0426042	Bag - 2 and 3.5 Bagger, LHC and RHC, Input Belt
497-0421485	Power Strip, IEC 4-POS, Plastic Case
* 497-0513382	Multiple Power Sources/ Disconnect Power Caution Label
* 007-9714414	Tiestrap Plain 5.60LG (2pcs)
* 497-0423108	Kit Instructions (Reference Sheet)

* Items marked with an asterisk are not called out on the image.

Installation Procedures

Installing the Bagwell upgrade involves the following procedures:

- [Removing Existing Bagwell](#) on the next page.
- [Changing Bagwell Orientation](#) on page 21.



Note: This procedure may be optional.

- [Installing New Bagwell](#) on page 28.
- [Installing Bagwell Skirt Panels](#) on page 36.
- [Routing Cables](#) on page 38.

Removing Existing Bagwell

To remove an existing 2-Bag Bagwell, follow these steps:



Note: To remove a 1-Bag Bagwell refer to [7350-K120/K121/K122/K123/K125/K962/K967 2-Bag Bagwell Upgrade](#). To remove a 3-Bag Bagwell refer to [7350-K160/K162/K164/K165/K996 3-Bag Bagwell Upgrade](#).

1. Detach the Scale Tray from the Bagwell by removing four (4) flat head screws.



Note: Remove bag racks if present.

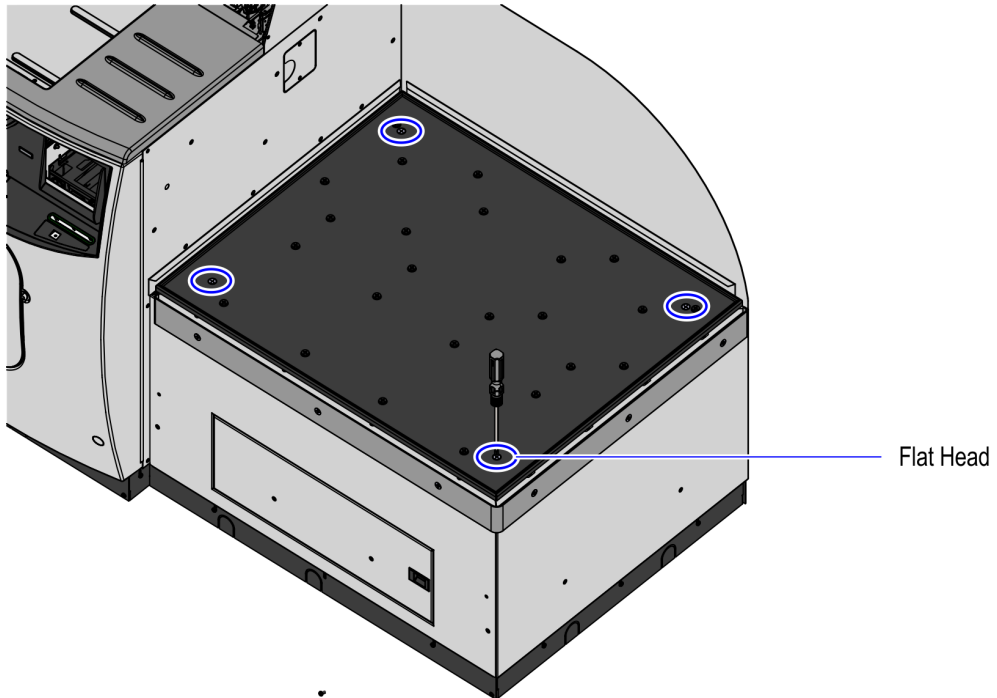

2. Remove the clear plastic deflectors from the Backsplash and side of the Core.



Note: Leave the Core side deflector in its place if the new Bagwell is attached on the same side.



Note: The 7350-K145 (Walmart Blue) variant does not have plastic deflectors and bumpers.

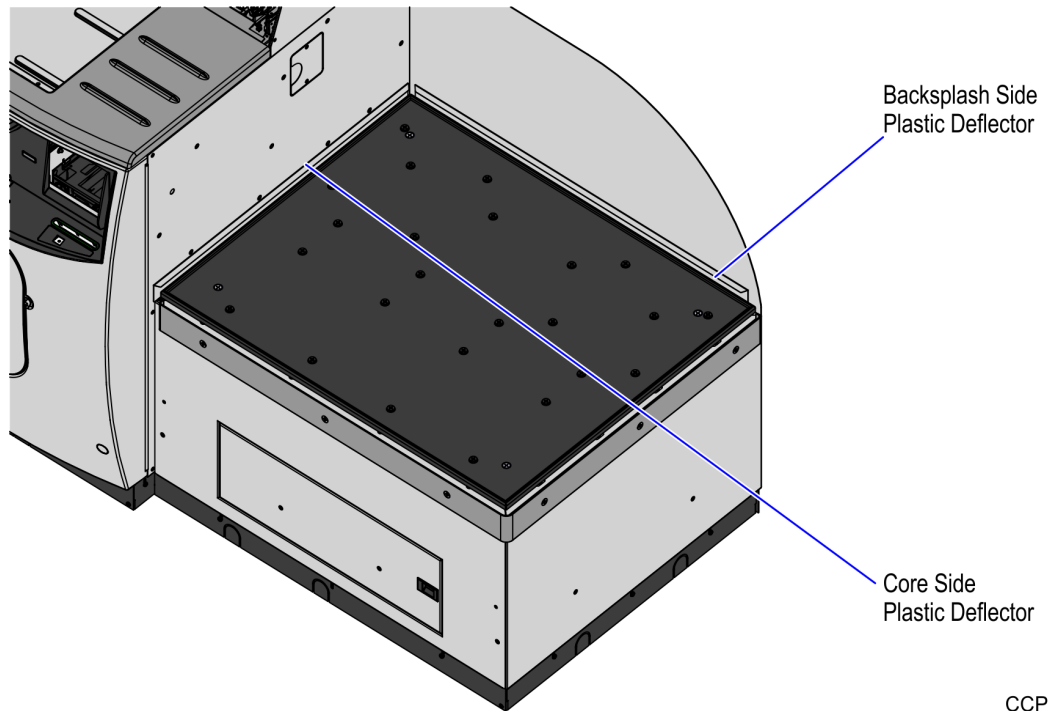

CCP-77366

3. Disconnect the following cables:



Note: The 7350-K145 (Walmart Blue) variant uses Top Spacer Brackets instead of a Scale Controller and Scale Pods.

- USB Power Cable from the Scale Controller
- Local Area Network (LAN) Cable from the Customer Interface
- AC Power Out Cables from the Power Strip
- AC Power In Cable from the Power Strip



Note: Remove cables from any routing clips or tie wraps if needed.

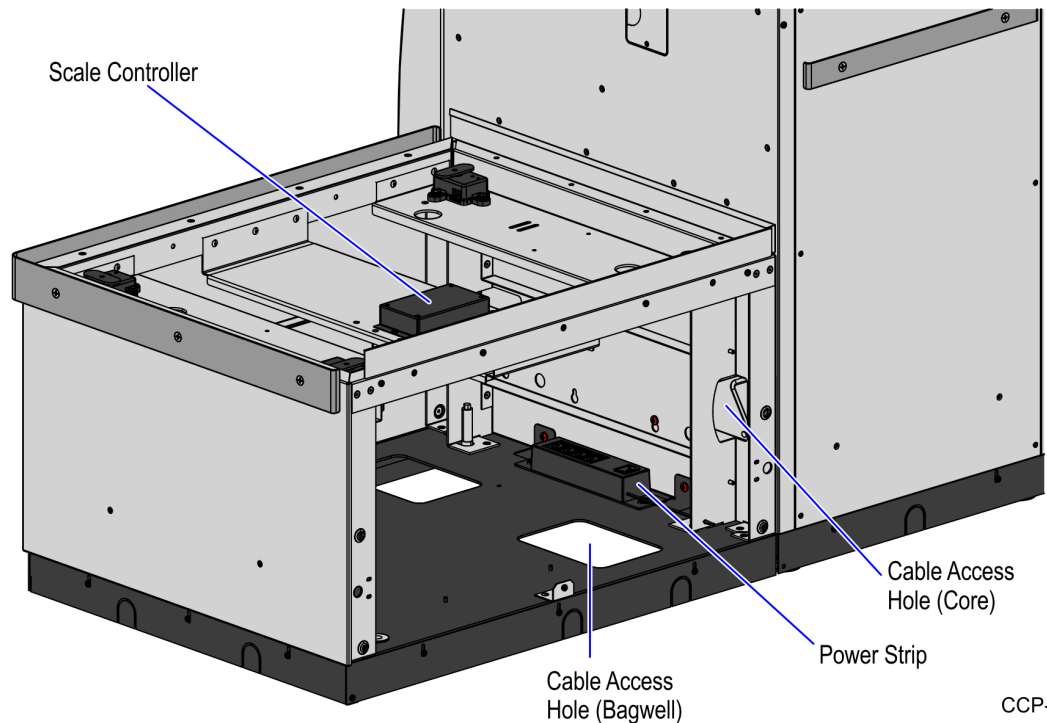

CCP-77367

4. Route the following cables through the cable access hole:



Note: The 7350-K145 (Walmart Blue) variant uses Top Spacer Brackets instead of a Scale Controller and Scale Pods.

Bagwell Cable Access Hole

- AC Power In Cable

Core Cable Access Hole

- USB Power Cable
- Local Area Network (LAN) Cable
- AC Power Out Cables



Note: Local Area Network (LAN) Cable and AC Power In Cable may be routed differently depending on the installation conditions.

5. Remove the upper rear screw attaching the Backsplash to the Core.

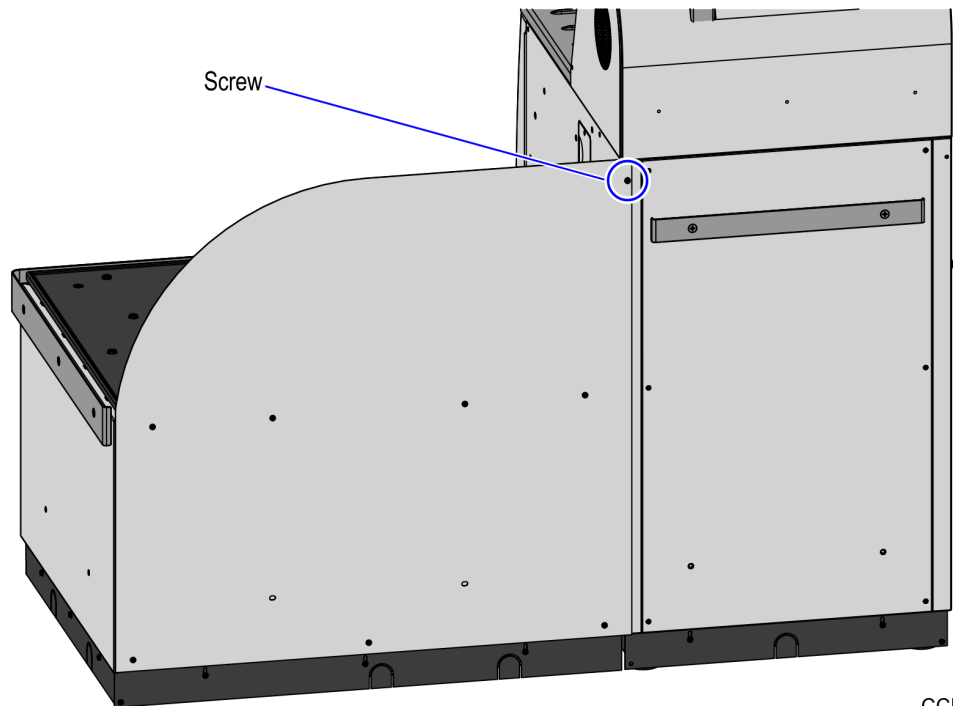

CCP-77368

6. Remove the Bagwell by doing the following:
 - a. Remove the two (2) bottom screws attaching the Bagwell to the Core. Screws are located on either side of power strip.

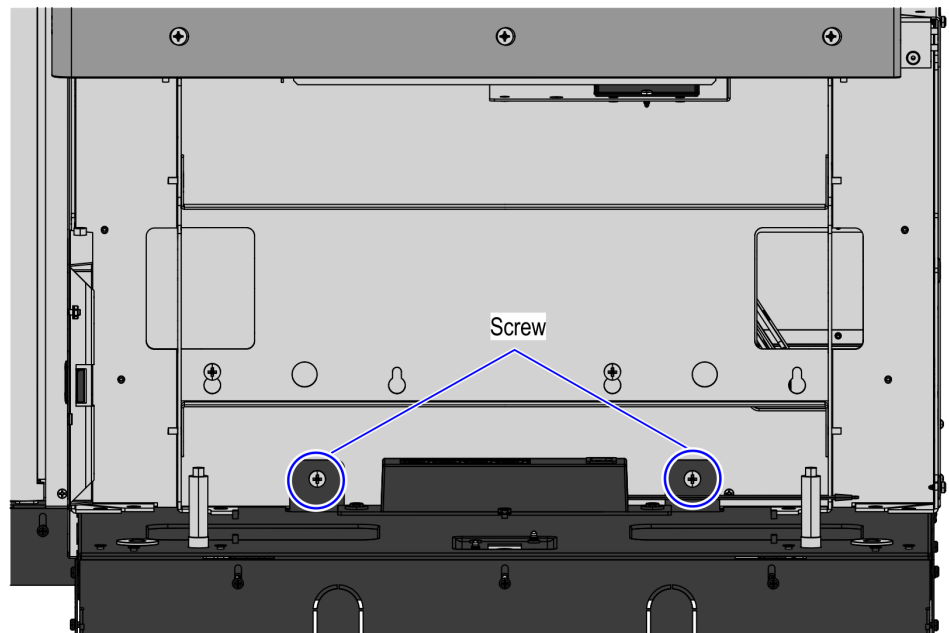

CCP-77315

- b. Loosen the two (2) upper screws, but do not remove.

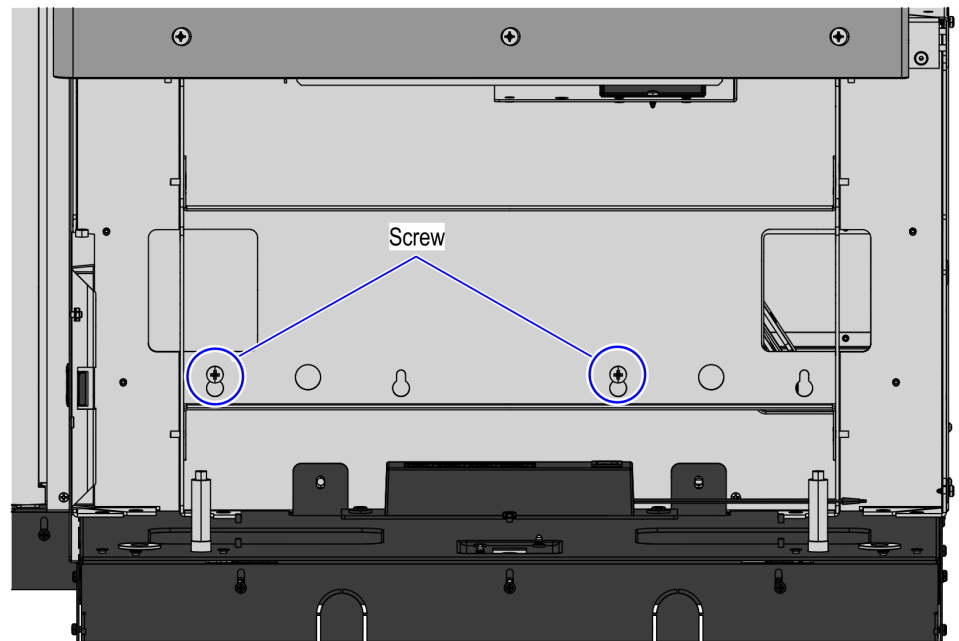

CCP-77316

- c. Lift Bagwell up and away from Core. The upper screw heads will pass through the key holes in the Bagwell side support.

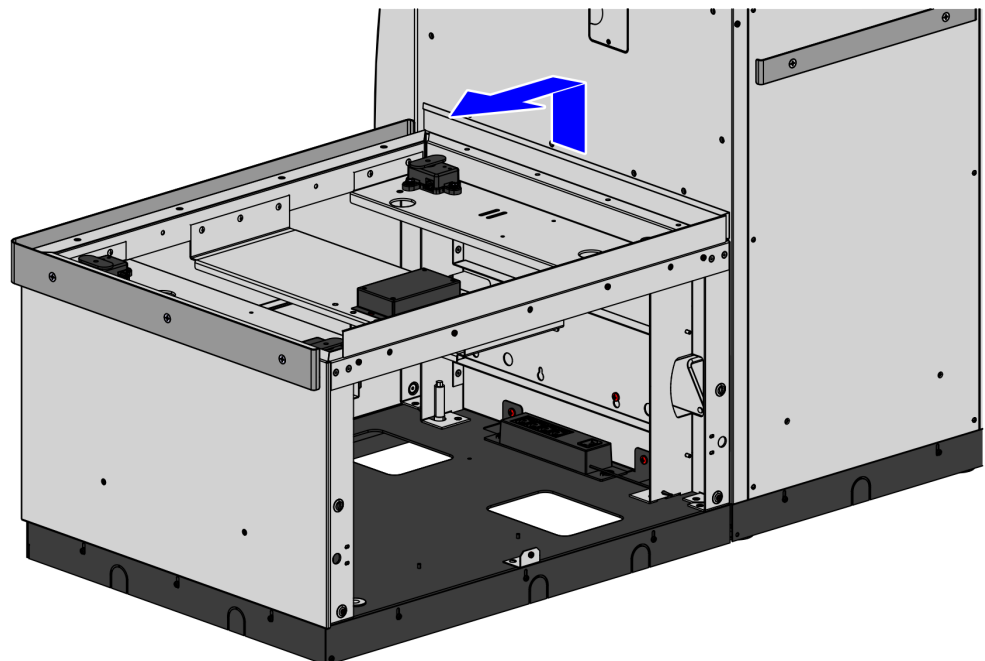

CCP-77369



Note: The two (2) upper screws may be left in place if a new Bagwell will be installed in the same orientation. Otherwise, remove the screws from the side of the Core.

Changing Bagwell Orientation

To change the Bagwell from right hand to left hand orientation, follow these steps:



Note: These steps should be done before attaching the Bagwell to the Core.

1. Detach the Scale Tray from the Bagwell by removing four (4) flat head screws.

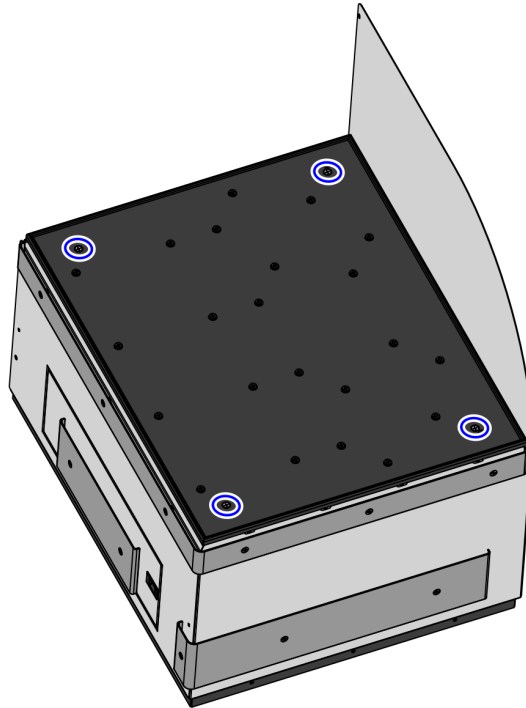

2. Remove the bumpers by doing the following:



Note: Do not remove the front access door bumper

- a. Detach the lower-rear bumper from the Bagwell by removing two (2) flat head screws.

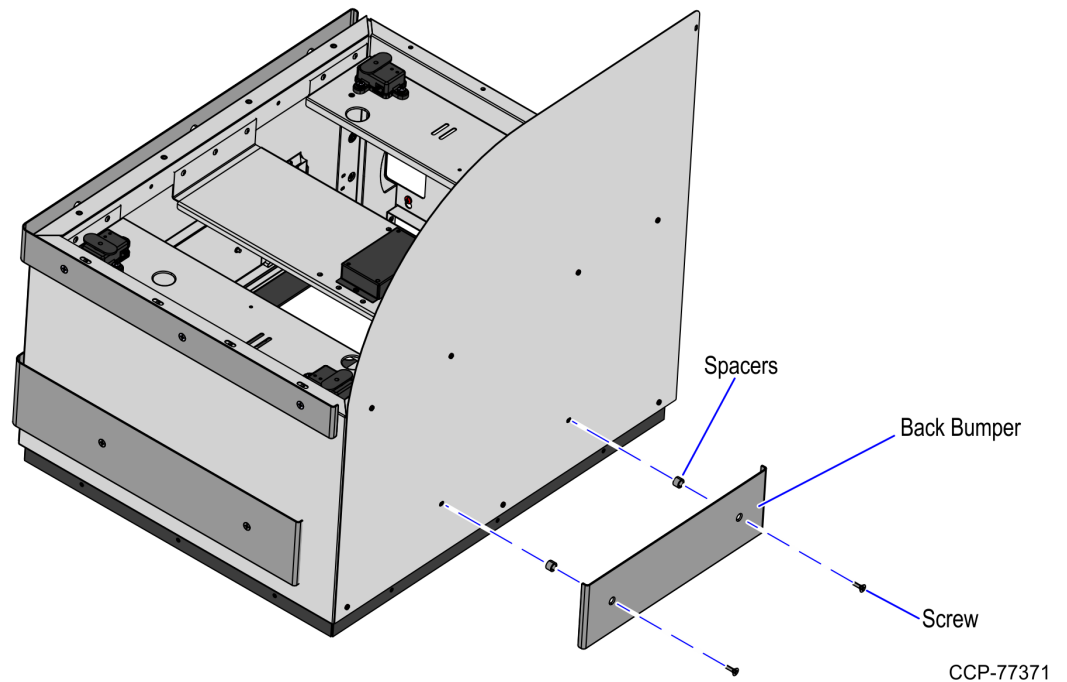

- b. Detach the Backsplash the Bagwell by removing seven (7) screws.

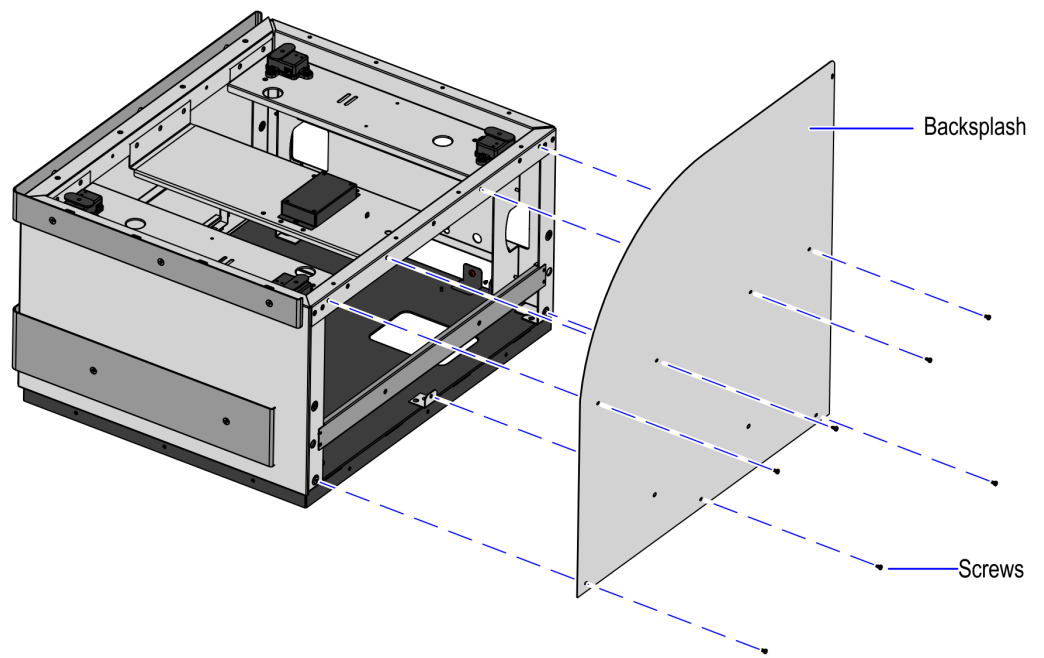

- c. Detach rear support frame from the Bagwell by removing four (4) nuts.

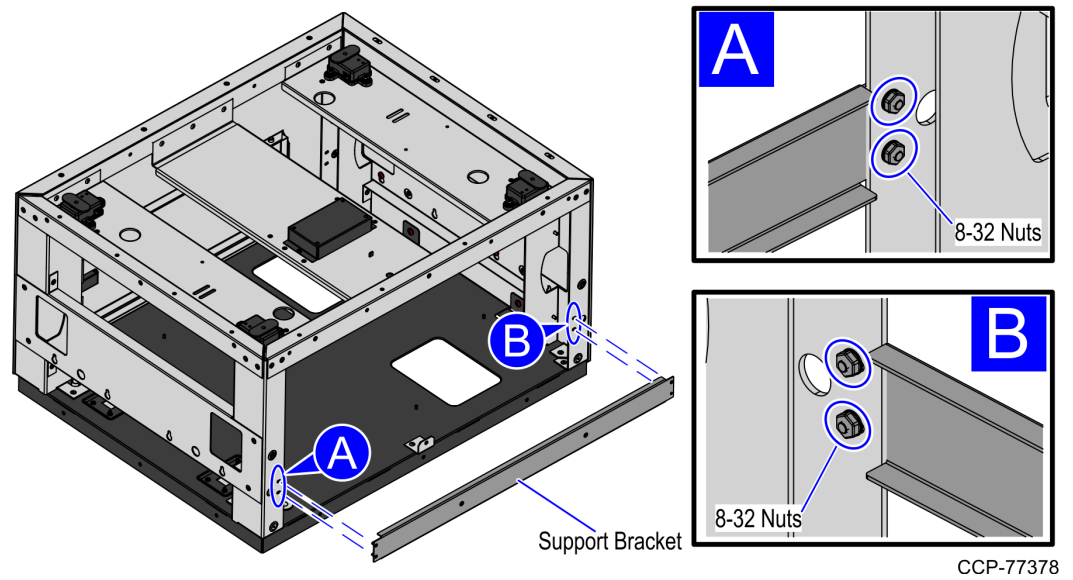

- d. Detach the upper bumper from the Bagwell by removing six (6) flat head screws and spacers, as shown in the image below.

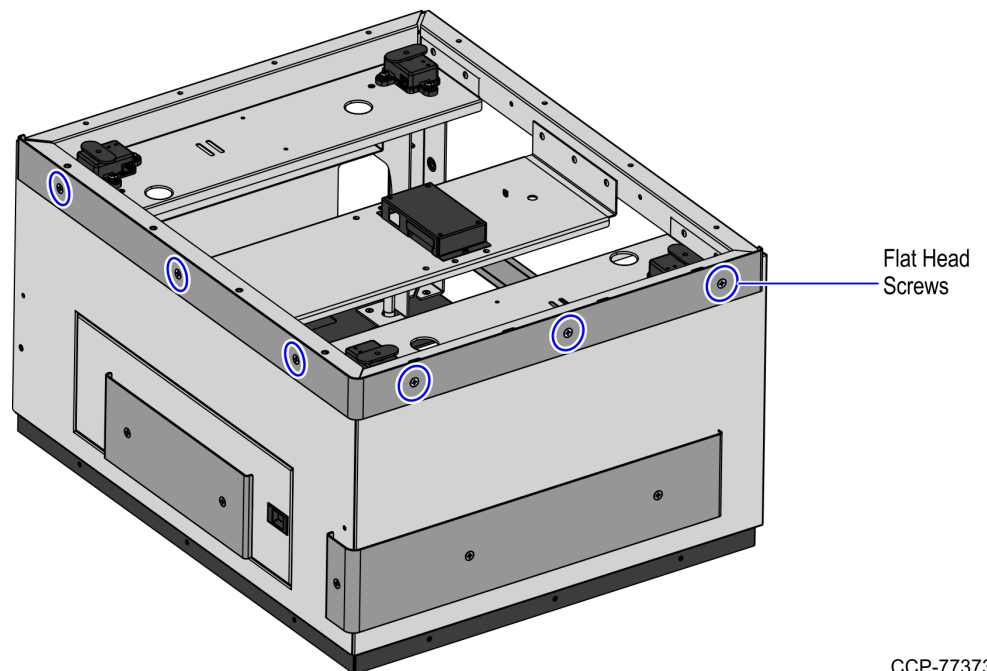

- e. Detach the wrap-around side bumper by removing three (3) flat head screws and spacers, as shown in the image below.

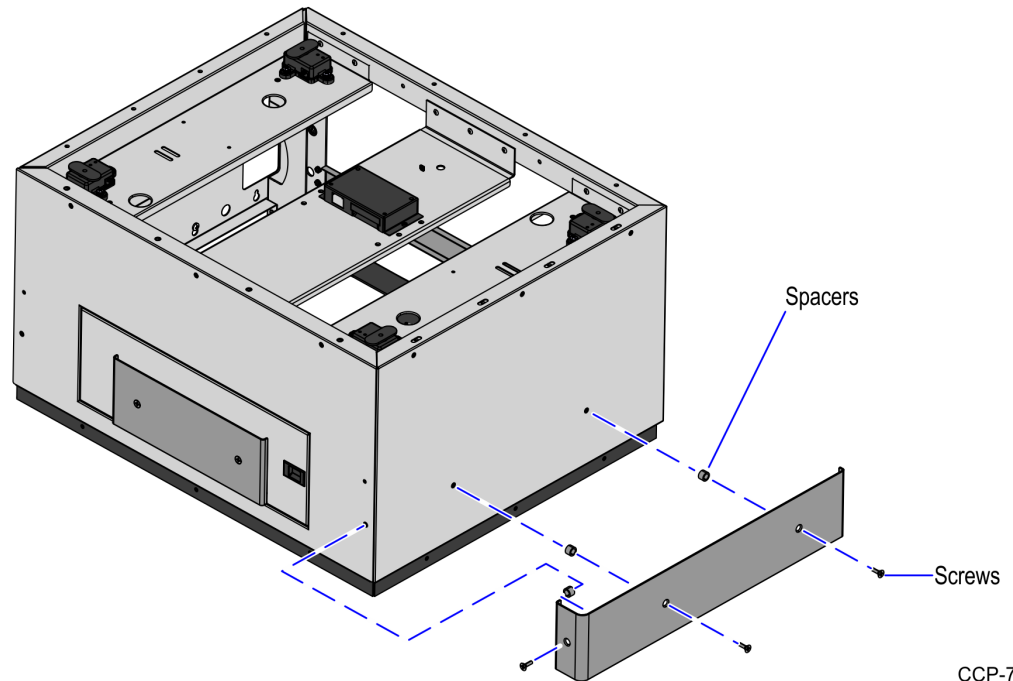

CCP-77374

3. Remove two (2) nuts securing the front panel to the Bagwell frame located at the inside corner posts.

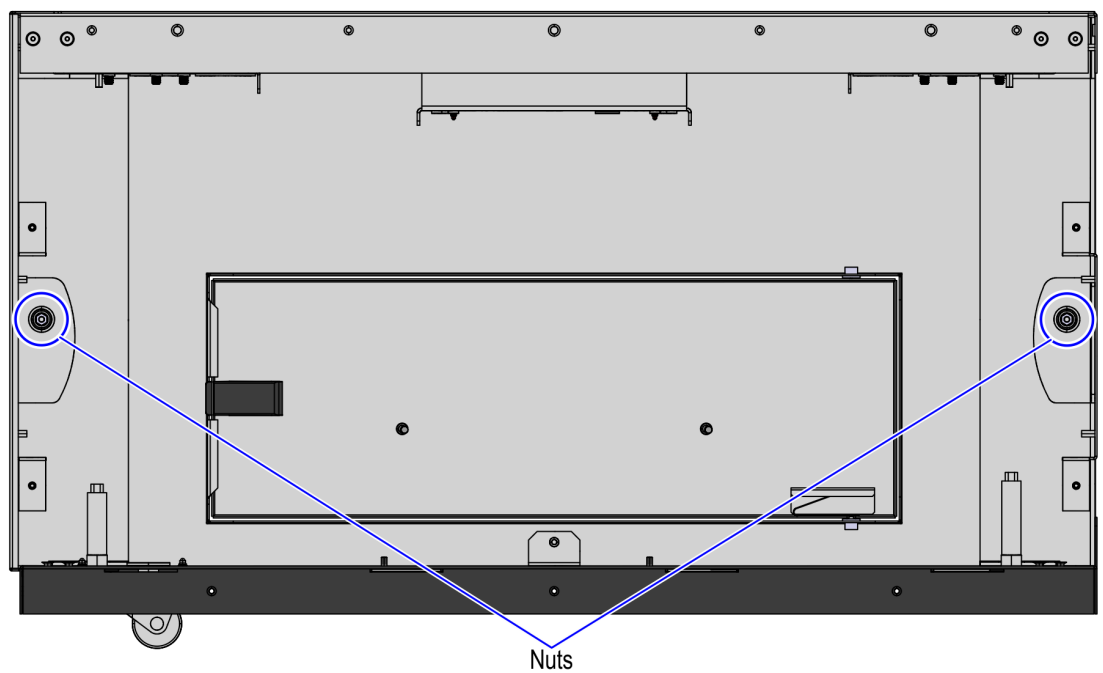

CCP-77375

4. Pull down the front panel and then pull out to disengage from the slots in the Bagwell frame base, as shown in the image below.

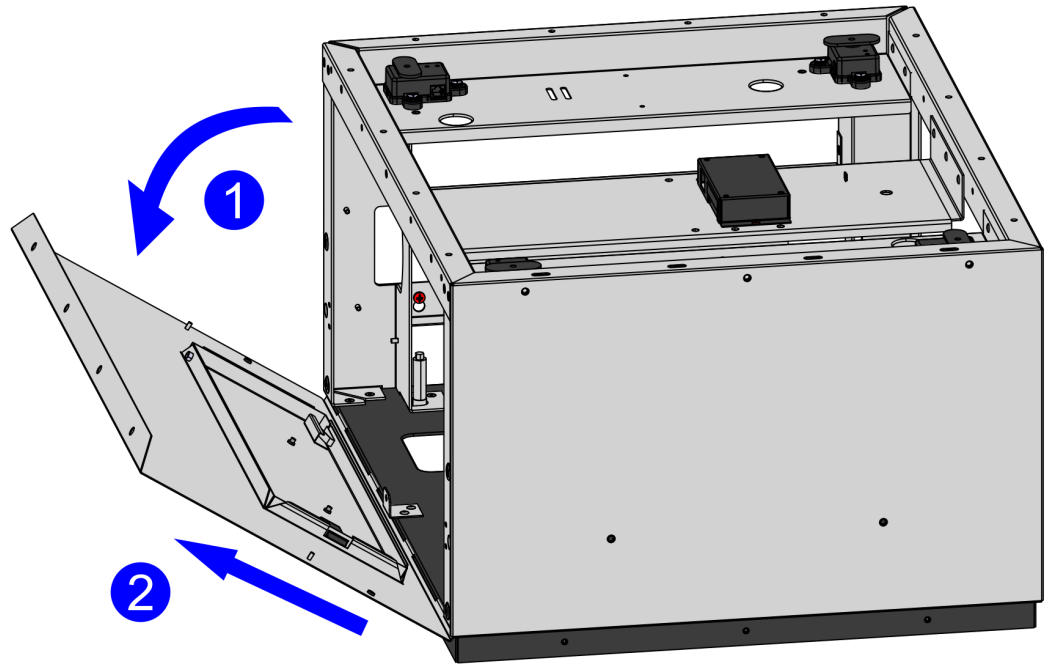

CCP-77376

5. Install the front panel on the opposite side of the Bagwell and secure it with two (2) nuts.



Note: Ensure that the the lower hook features are properly aligned with the slots in the Bagwell frame base.

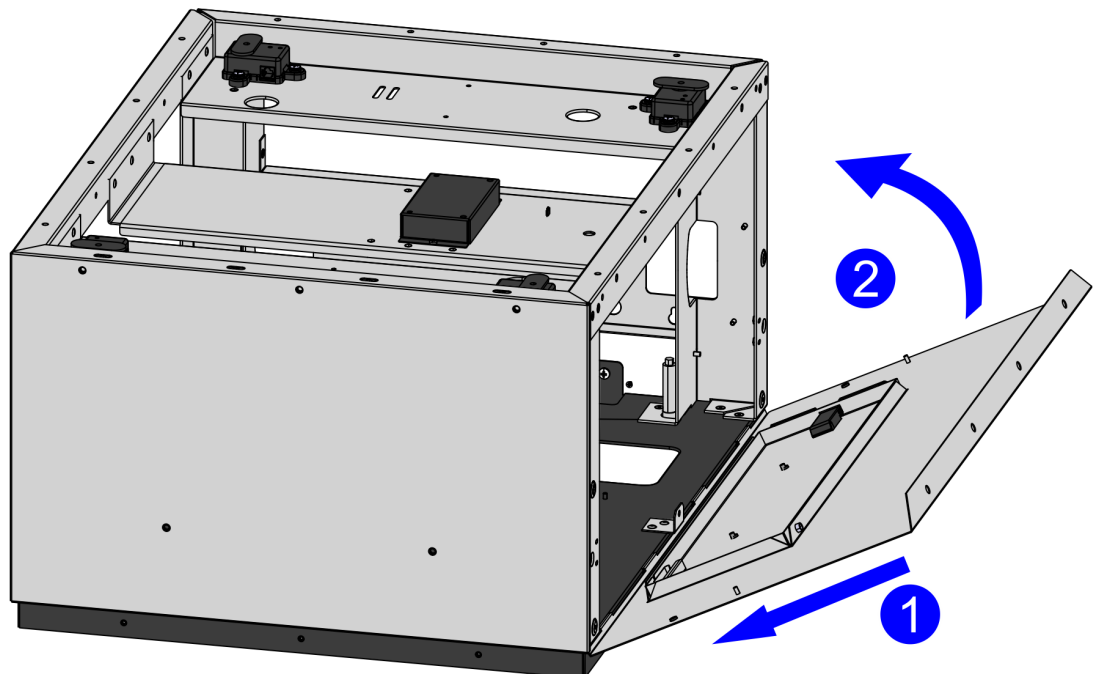

CCP-77377

6. Install the bumpers to the Bagwell by doing the following:



Note: Do not reinstall Scale Tray, Backsplash panel, and rear lower bumper (if present). For more information, refer to [Installing New Bagwell](#) on page 28.

- a. Attach the rear frame support by using four (4) nuts.
- b. Attach the upper stainless steel bumper to the Bagwell by using six (6) flat head screws and spacers.

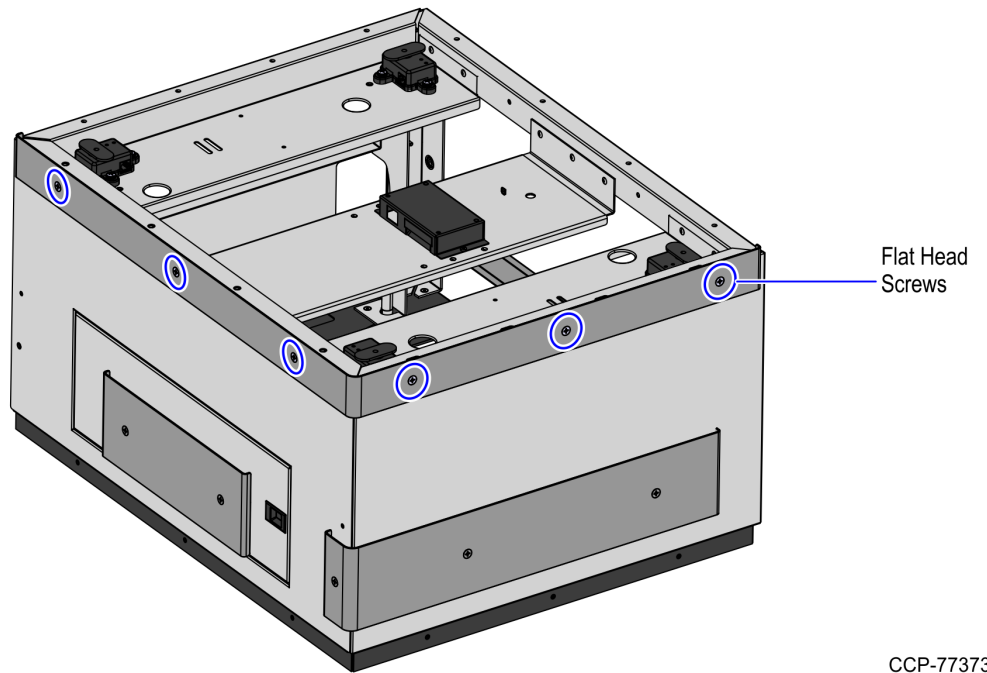

CCP-77373

- c. Attach the wrap-around bumper to the Bagwell by using three (3) flat head screws and spacers.

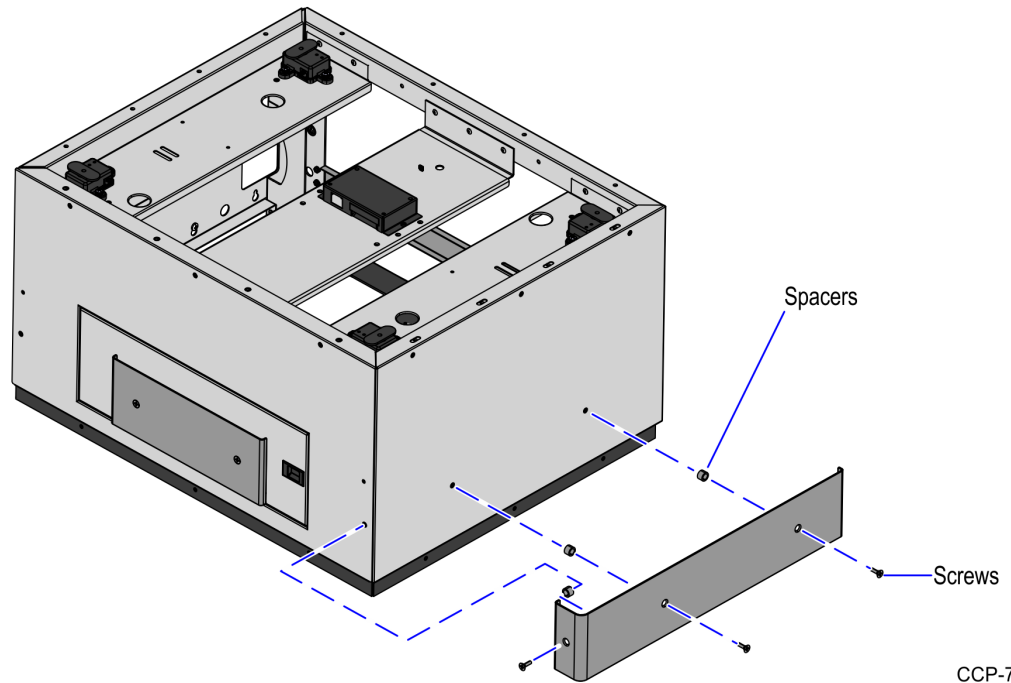

CCP-77374

Installing New Bagwell

To install the new Bagwell, follow these steps:



Note: If changing the Bagwell orientation (Left-Hand or Right-Hand), ensure that the orientation is changed before installing the new Bagwell to the Core.

1. Remove the Scale Tray from the Bagwell.
2. Remove the lower access panel from the Core side where the new Bagwell will be attached. Reinstall the access panel on the opposite side of the Core.



Note: This panel does not need to be reinstalled when attaching a Bagwell to a No-Bag Unit.

Right-hand Configuration

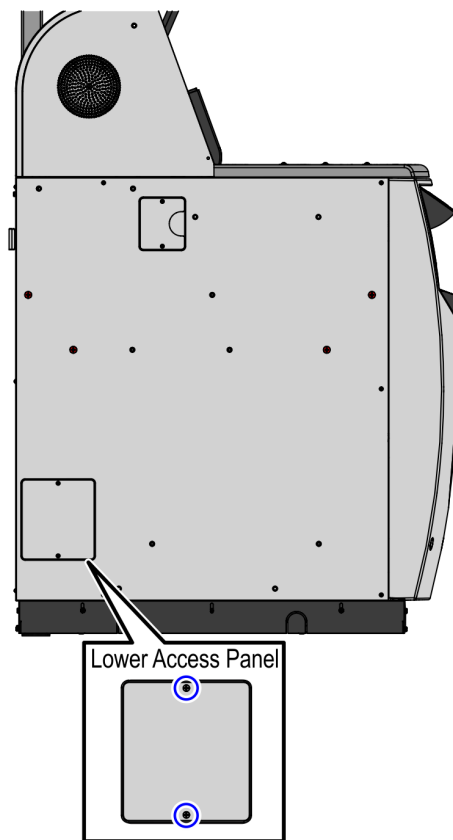

Left-hand Configuration

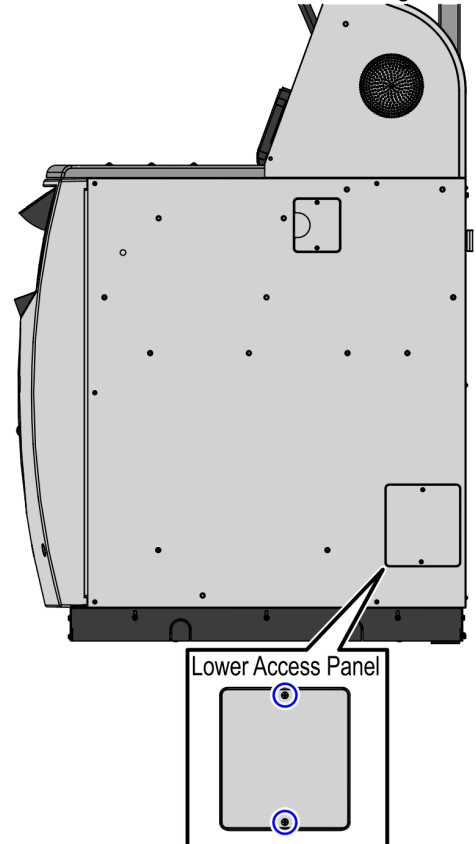

3. Lower all the leveling feet of the Bagwell slightly beyond the height of the casters to assist in lining up the Core and the Bagwell mounting holes.

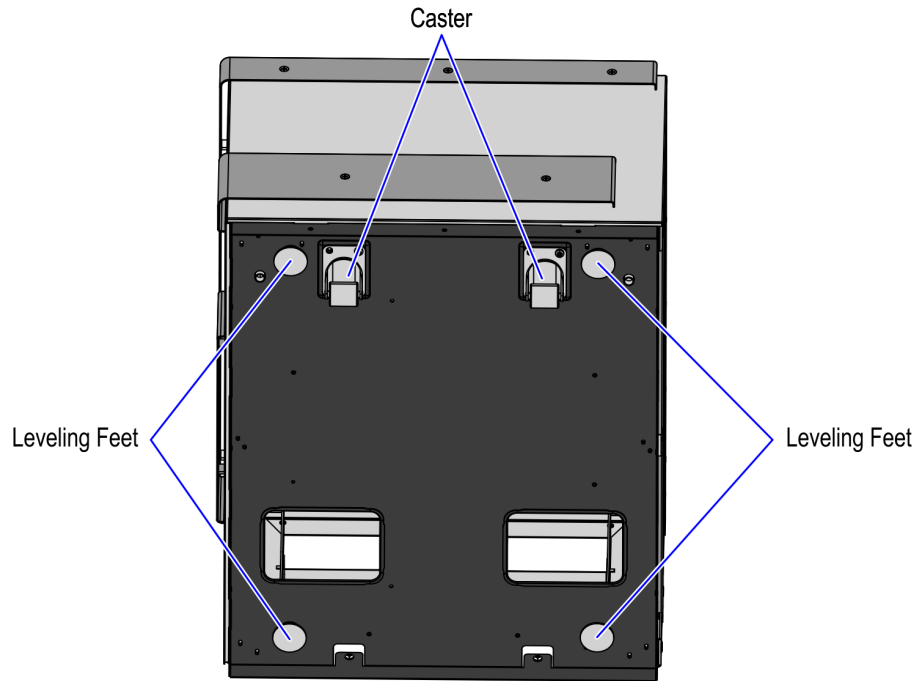

CCP-77379

4. Install the new Backsplash panel using seven (7) screws.

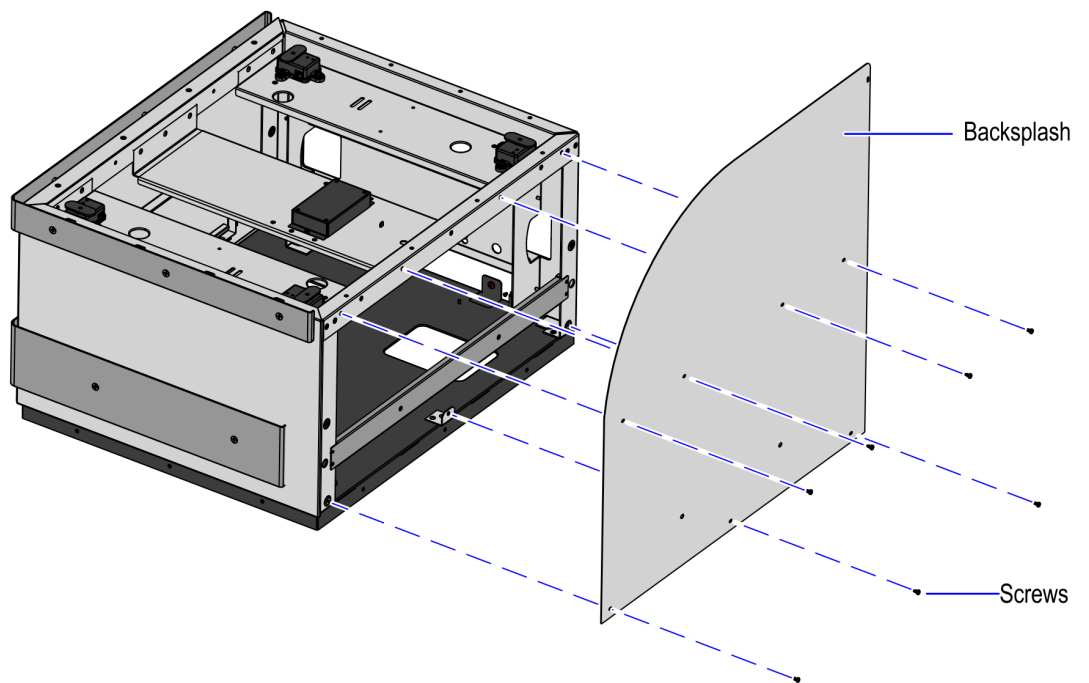

CCP-77372

5. If not already present, partially thread the two (2) upper screws on the Bagwell side of the Core. Leave approximately $\frac{1}{4}$ inch of the threads exposed.

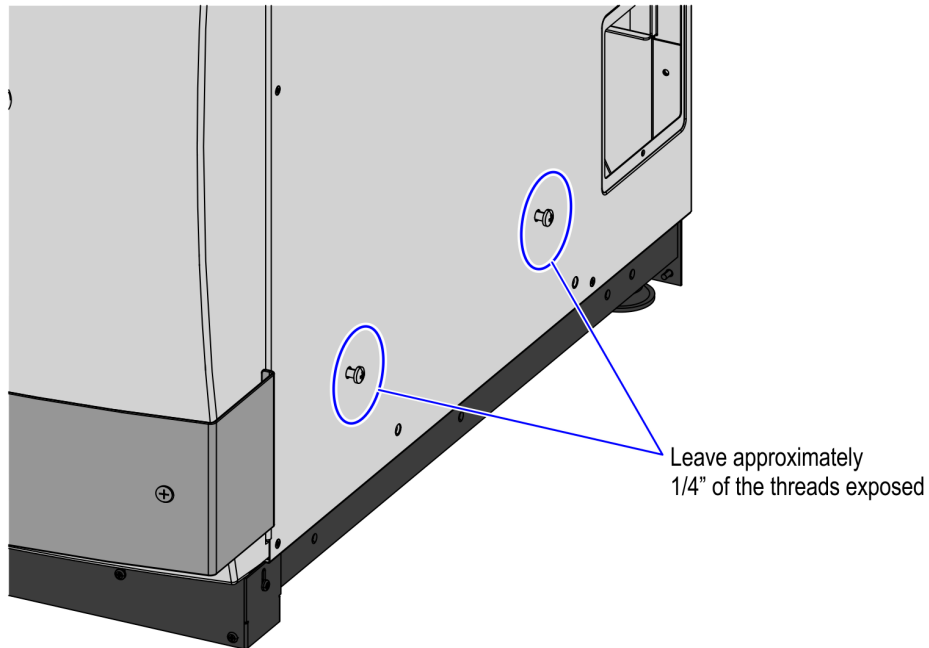

CCP-77329

6. Mate the new Bagwell to the Core by lifting the frame up and over the partially threaded screws.



Note: Ensure that the two frontmost key holes on the Bagwell are used.

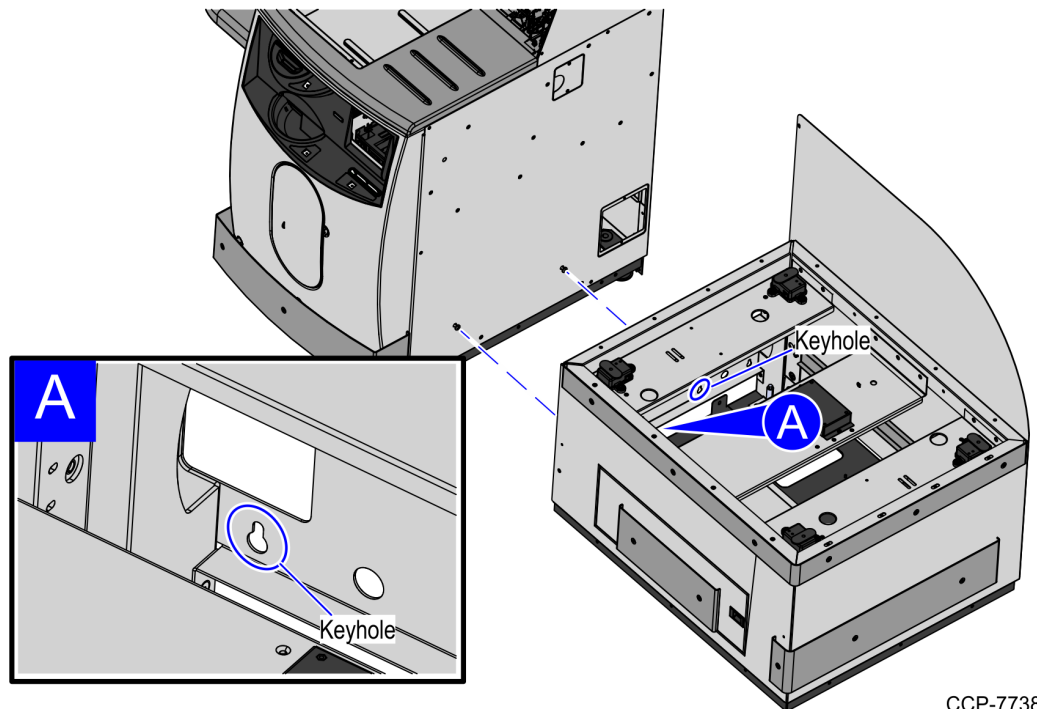

CCP-77380

7. Tighten the two (2) screws and install the two (2) lower screws that connect the Bagwell and the Core.

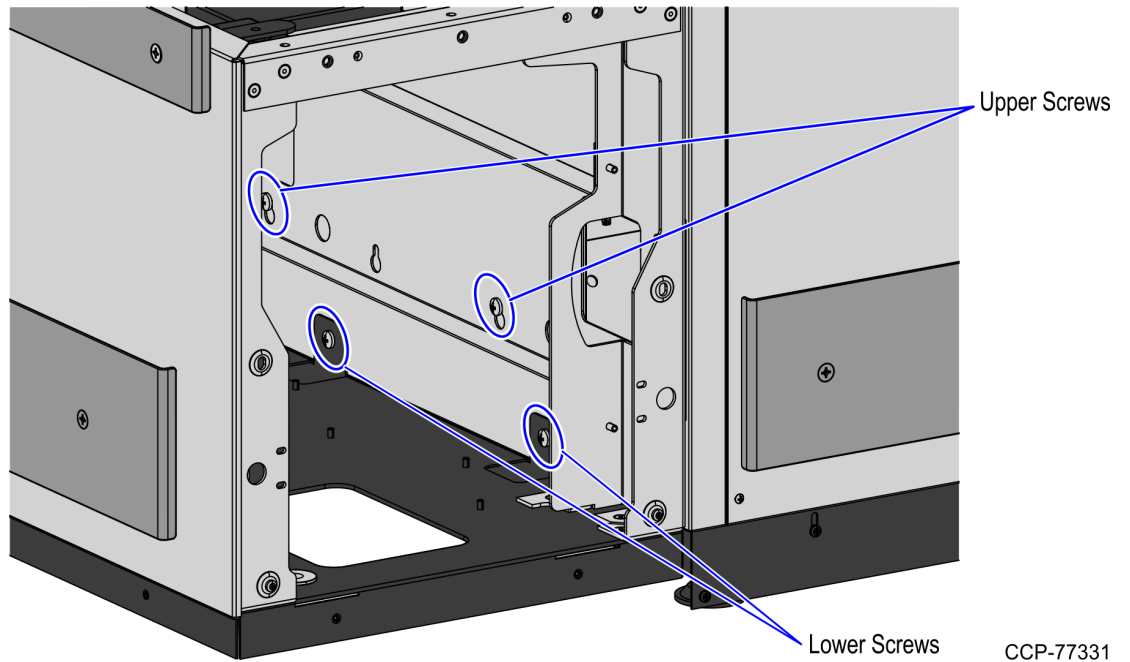

8. Install the upper rear screw attaching the Backsplash panel to the Core.



Note: Adjust the leveling feet if the slot does not line up well.

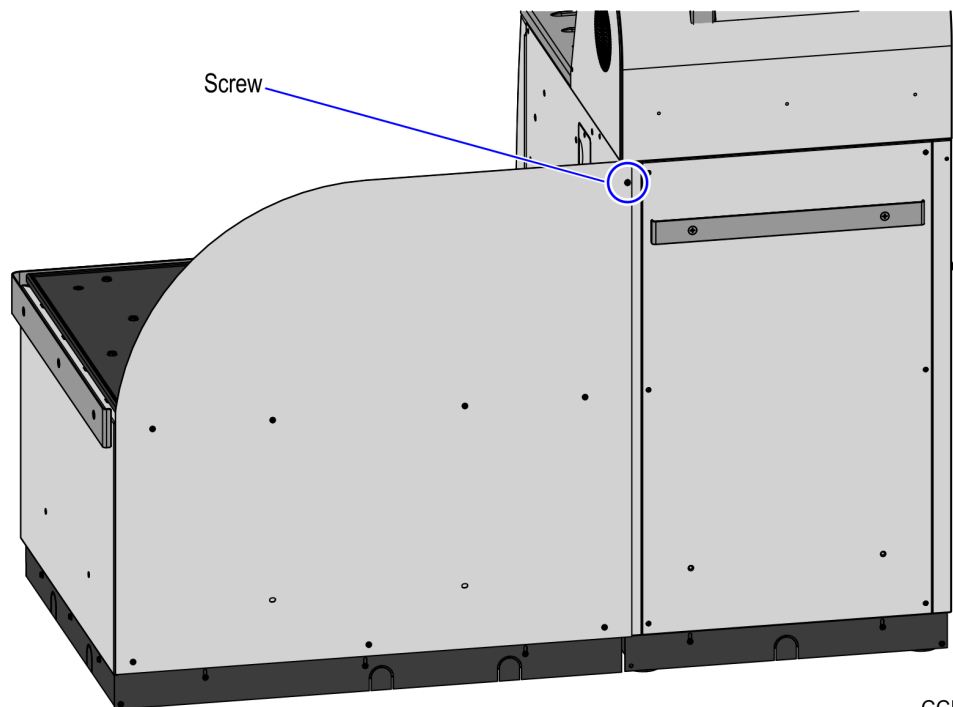

9. If present, install rear lower bumper using two (2) plastic spacers and two (2) flat head screws on the Backsplash.

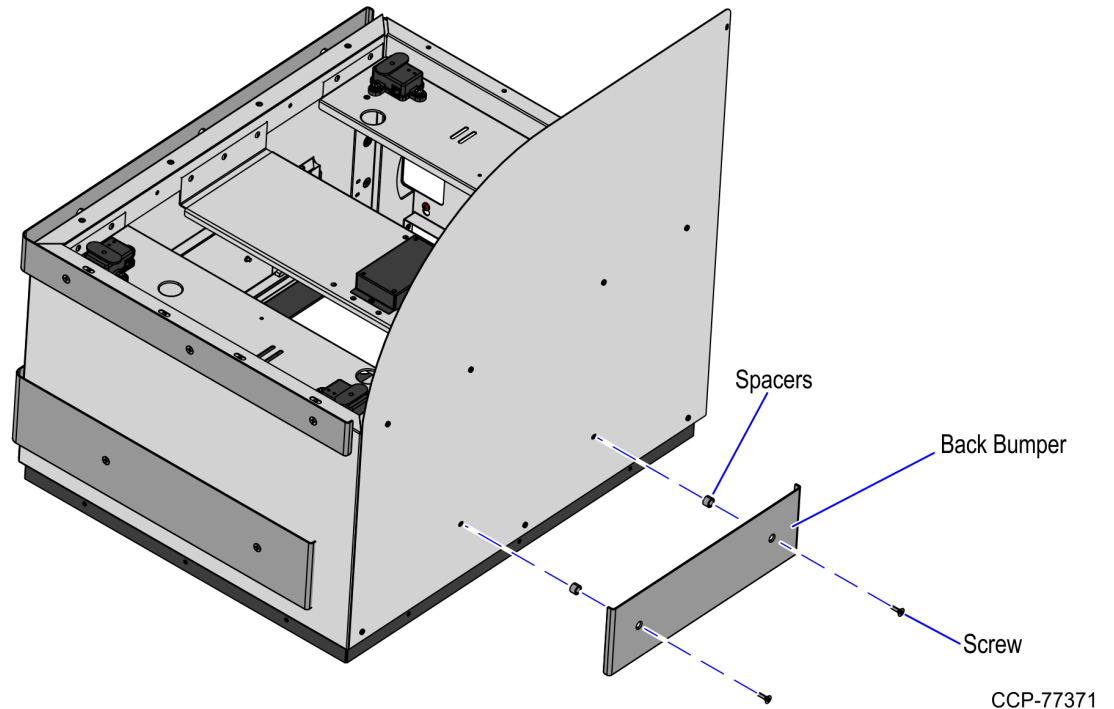

10. Route the following cables through the cable access hole:



Note: The 7350-K145 (Walmart Blue) variant uses Top Spacer Brackets instead of a Scale Controller and Scale Pods.

Bagwell Cable Access Hole

- AC Power In Cable

Core Cable Access Hole

- USB Power Cable
- Local Area Network (LAN) Cable
- AC Power Out Cables

For more information, refer to [Routing Cables](#) on page 38.

11. Remove four (4) yellow shipping spacers from the scale pods before installing the Scale Tray.



Note: The 7350-K145 (Walmart Blue) variant uses Top Spacer Brackets instead of a Scale Controller and Scale Pods.

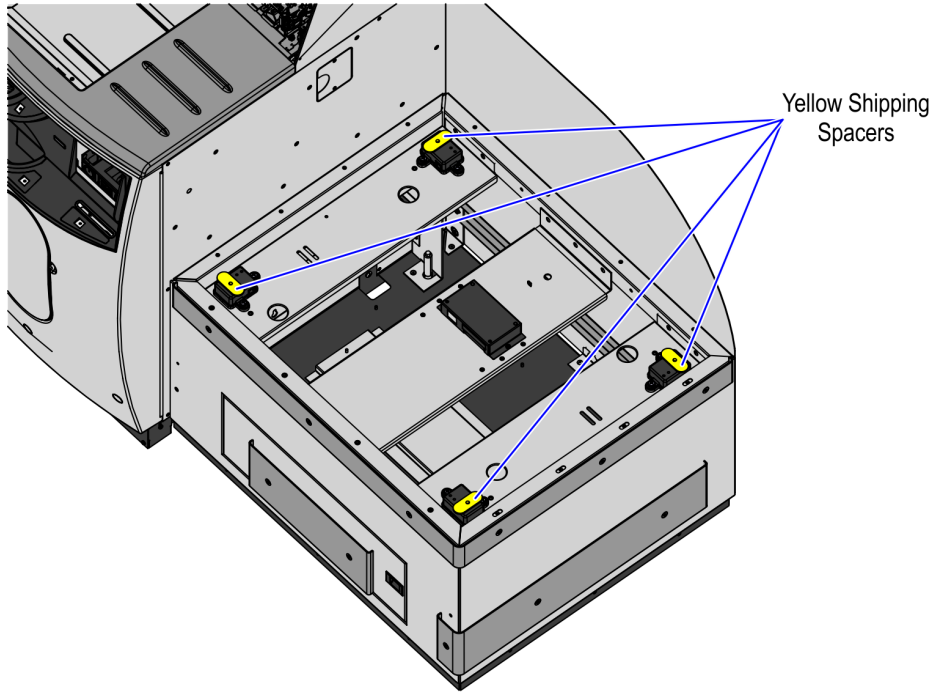

12. Install the Scale Tray on the Bagwell using four (4) flat head screws.



Note: Ensure that the surface marked **BACK** is facing towards the back of the unit.

! Important: Use the correct screw length. Tighten the screws from six to eight pounds. Do not overtighten the screws to prevent inaccurate scale readings.

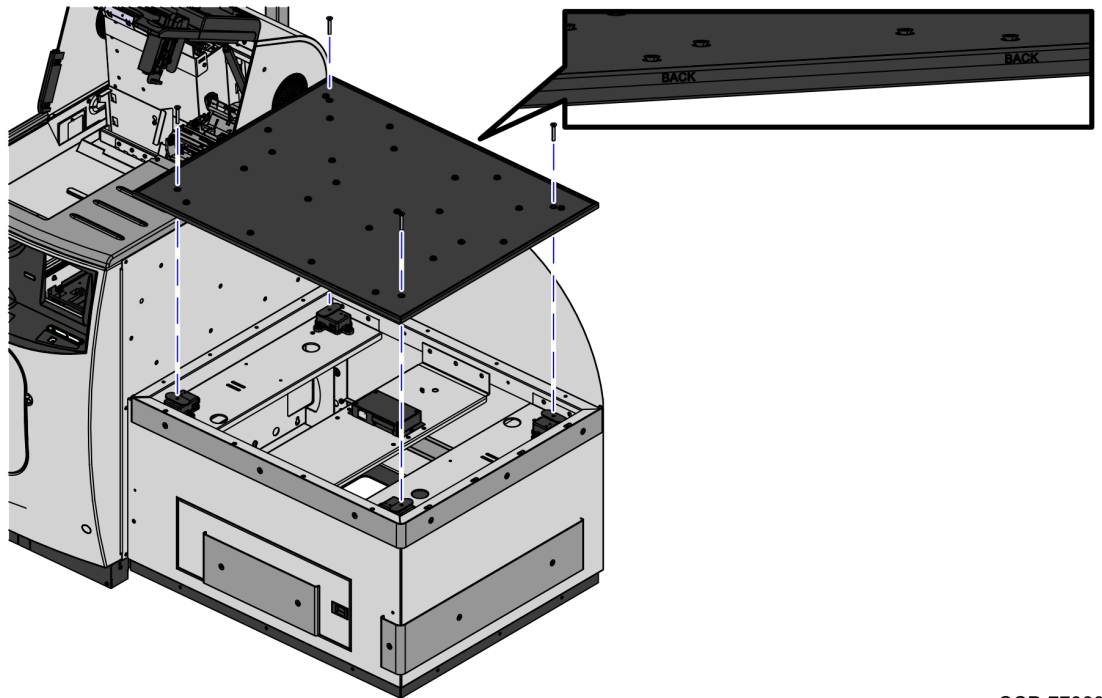

13. Install clear plastic deflectors to the Core side and rear side of the Bagwell. Ensure that the deflectors meet at the rear and Core side corners, and should rest against the Bagwell frame.

! Important: Plastic deflectors must **not** touch the Scale Tray surface to avoid scale errors.

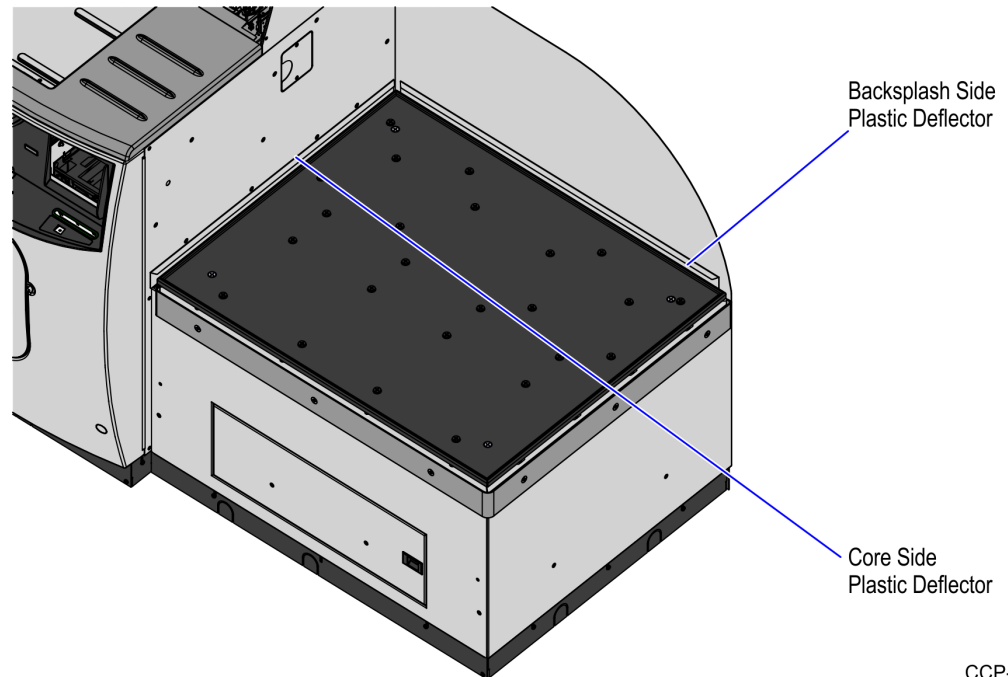

CCP-77366

14. Attach the Bagwell Skirt Panels. For more information, refer to [Installing Bagwell Skirt Panels](#) on the next page.
15. Do the following:
 - Level the unit and attach the bag racks, if necessary. For more information, refer to the 7350 NCR SelfServ™ Checkout (7350) Hardware Installation Guide (B005-0000-1826).
 - Test scale operation in PML. For more information, refer to the NCR FastLane SelfServ™ Checkout Profile Manager Lite (PML) User Guide for ADD 3.X (B005-0000-2279).

Installing Bagwell Skirt Panels

To install Bagwell skirt panels, follow these steps:

1. On the side of the Bagwell, do the following:

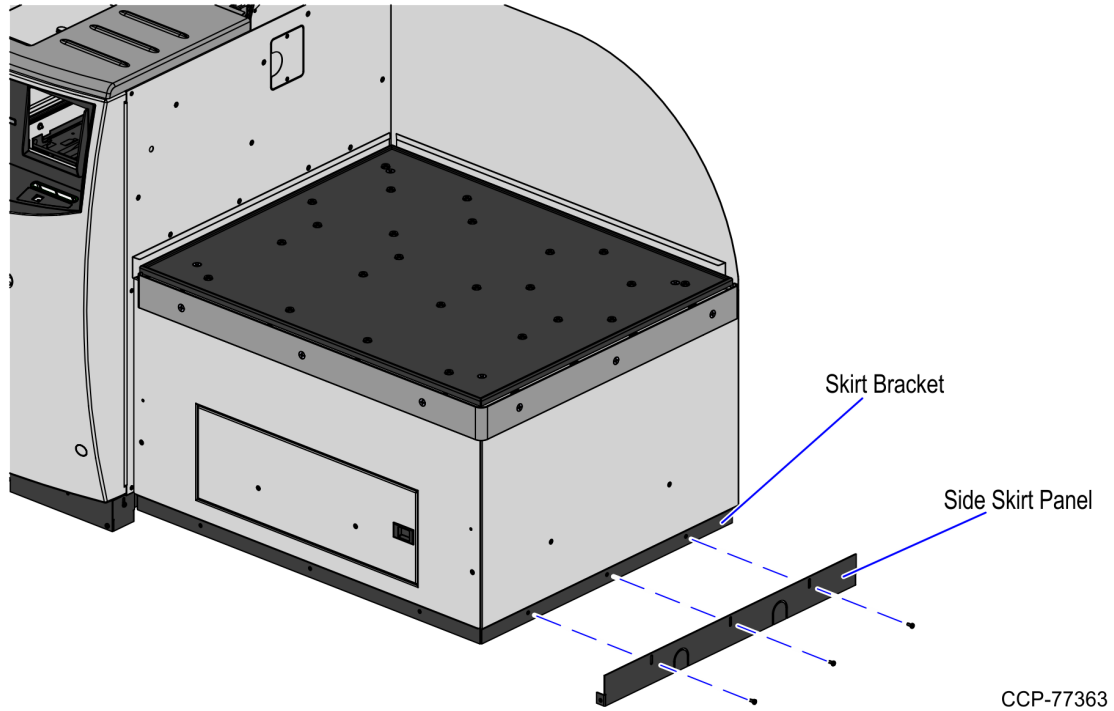

CCP-77363

- a. Attach the skirt panel to the skirt brackets by aligning the open slots in the skirt panel with the screw holes in the skirt bracket.
- b. Secure the skirt panel to the bracket using three (3) screws.
- c. Adjust the skirt panel so that it is flush with the floor.
- d. Tighten the screws to secure the skirt in place.

2. On the front and back of the Bagwell, do the following:



Note: The front and back skirt panels of the Bagwell must be installed after the side skirt panel of the Bagwell.

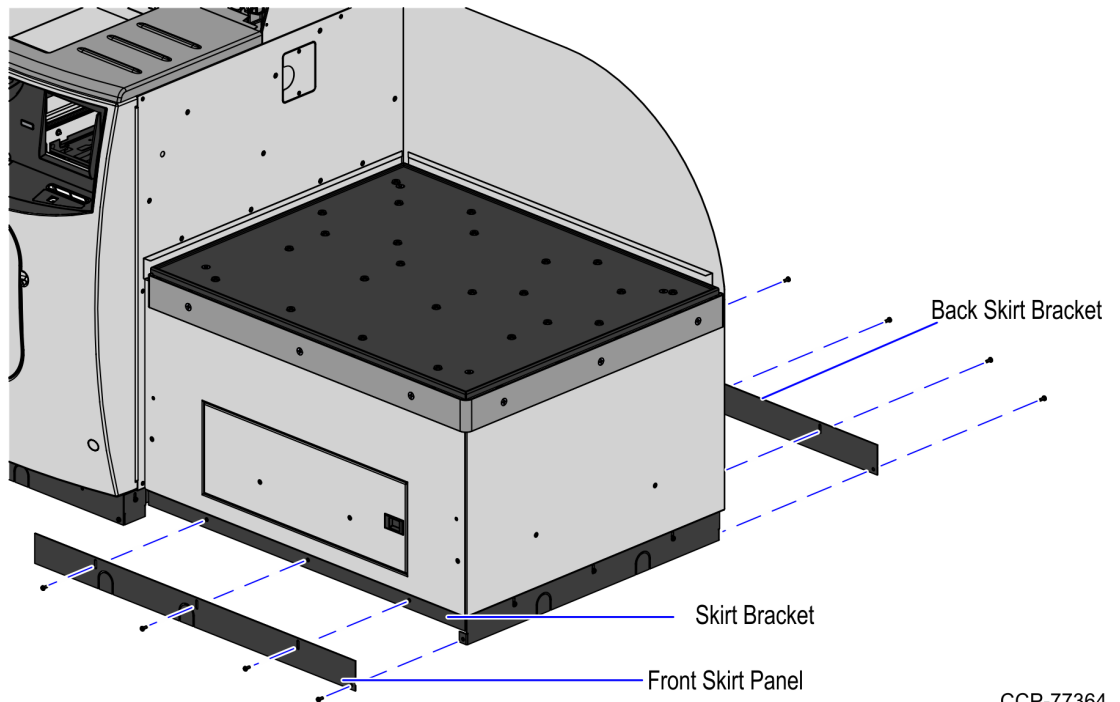

CCP-77364

- a. Attach the front and back skirt panels to the skirt brackets by aligning the open slots of both skirt panels with the screw holes in the securing bracket.
- b. Secure both skirt panels to the bracket using eight (8) screws.
- c. Adjust the skirt panel so that it is flush with the floor.
- d. Tighten the screws to secure the skirt in place.

Routing Cables

To route cables when installing a new Bagwell follow these steps:



Note: If a new Bagwell is installed to a No-Bag unit, refer to [Routing Cables for No-Bag unit](#) on page 41 first for additional steps.



Note: Use the new pre-installed USB Power Cable only when installing a new Bagwell to a No-Bag unit. If not, reuse the existing USB Power Cable of the previous Bagwell.

1. Retrieve the USB Power Cable from the Core and route to the Scale Controller through the smaller opening of the Bagwell frame as shown in the image below.

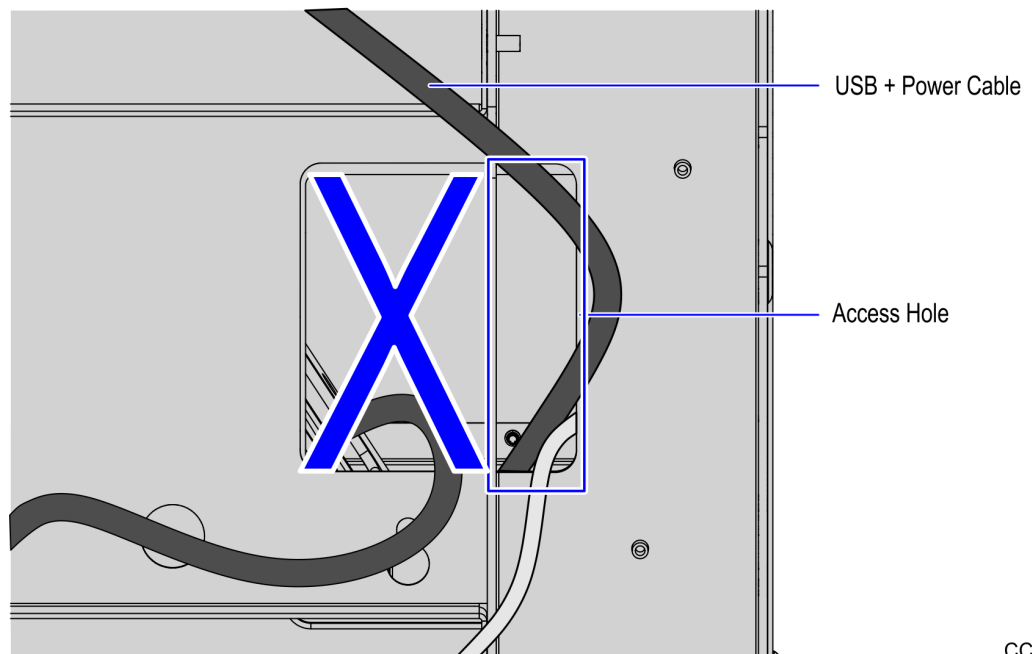

2. Tie the USB Power Cable with cable ties to hold it in place.

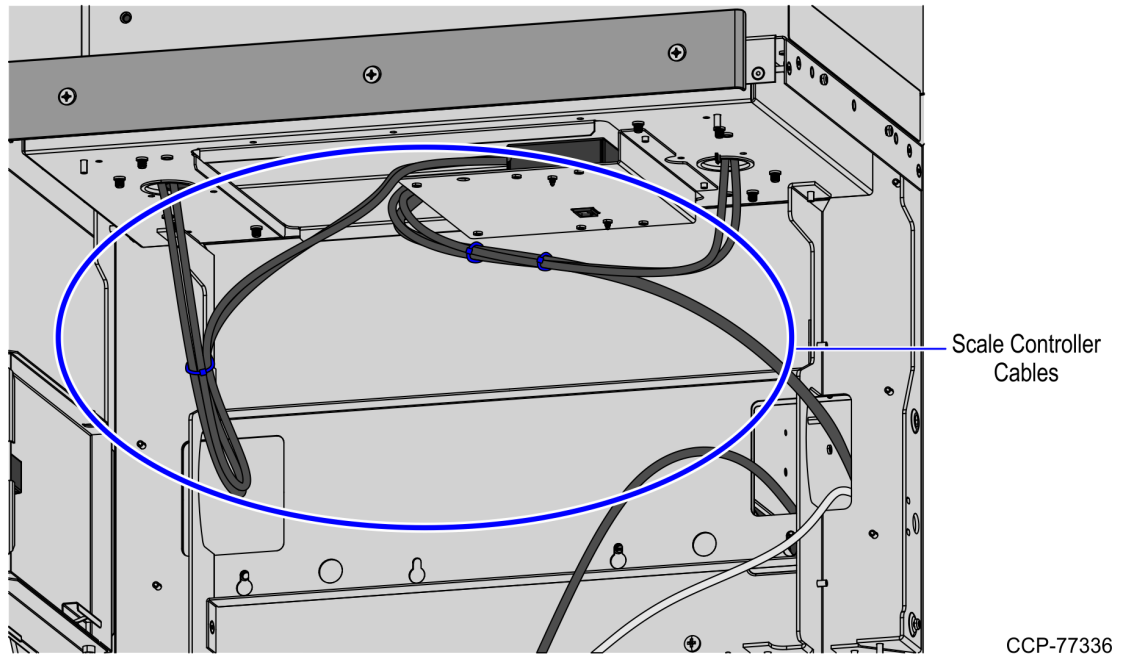

3. Route the Local Access Network (LAN) Cable from the Core to the Customer Interface through the smaller opening of the Bagwell frame as shown in the image below.

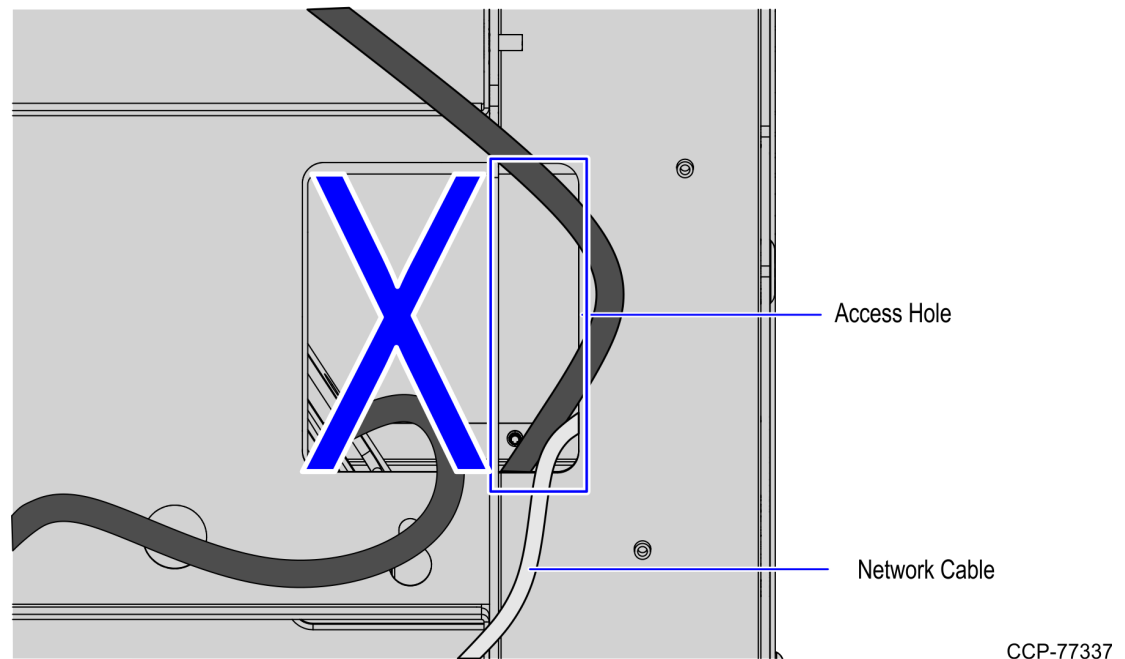

4. Route the AC Power Out and AC Power In cables and then connect to the Power Strip, as shown in the image below.

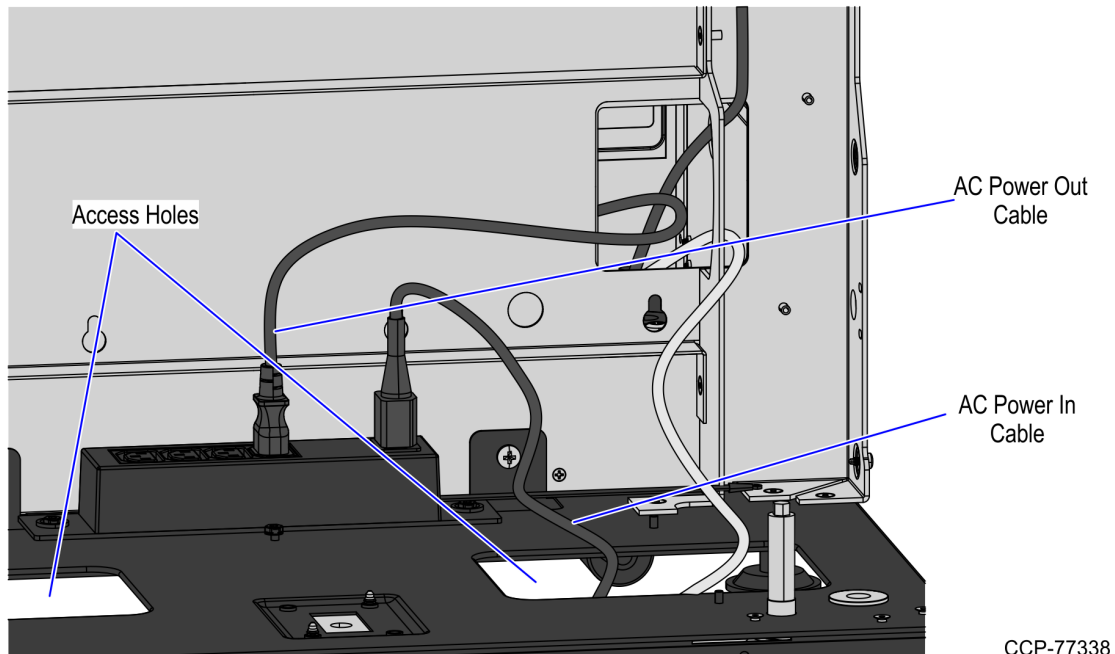

Routing Cables for No-Bag unit

These are additional steps in routing cables when upgrading a No-Bag unit to a 1-Bag unit:



Note: Use the new USB Power Cable. Route the USB Power Cable to the E-Box first before installing new Bagwell.

1. Unlock and open the upper Cabinet Door.
2. Lift the Scale Plate from the Scanner.

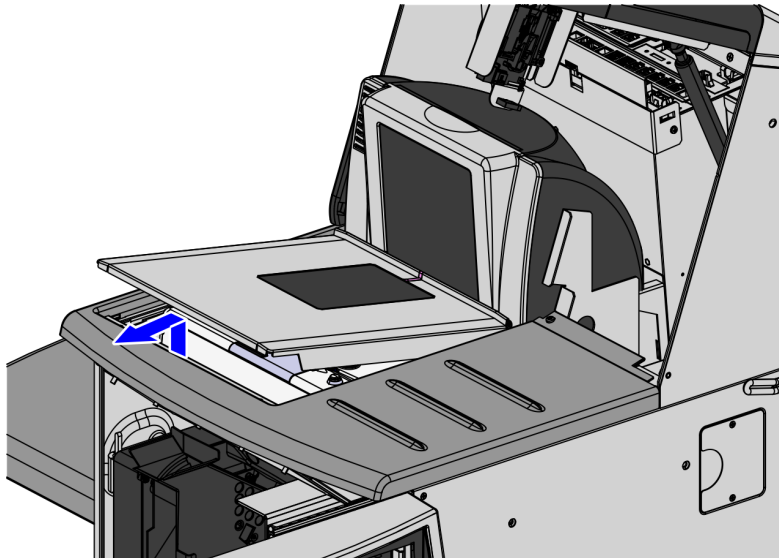

3. Do the following to remove the Scanner/Scale from the scanner bucket area.
 - a. Grasp the front of the Scanner and lift up.
 - b. Grasp the back of the Scanner and slide scanner out of the bucket area.

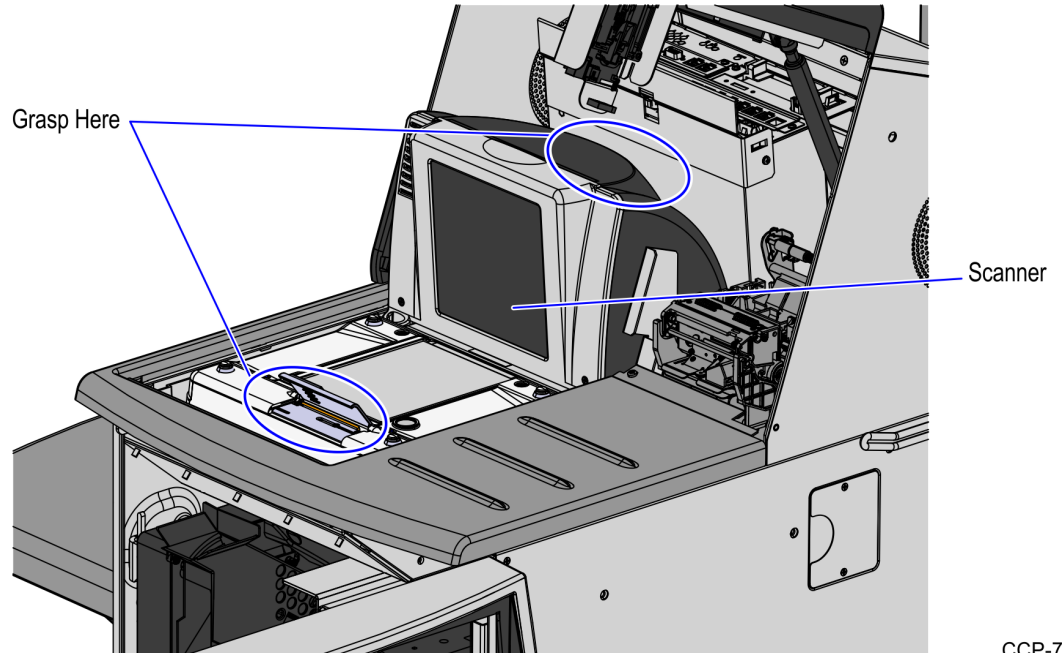

CCP-77347

4. Detach the rear Core panel by removing six (6) screws to access the main cable bundle and Power Strip.

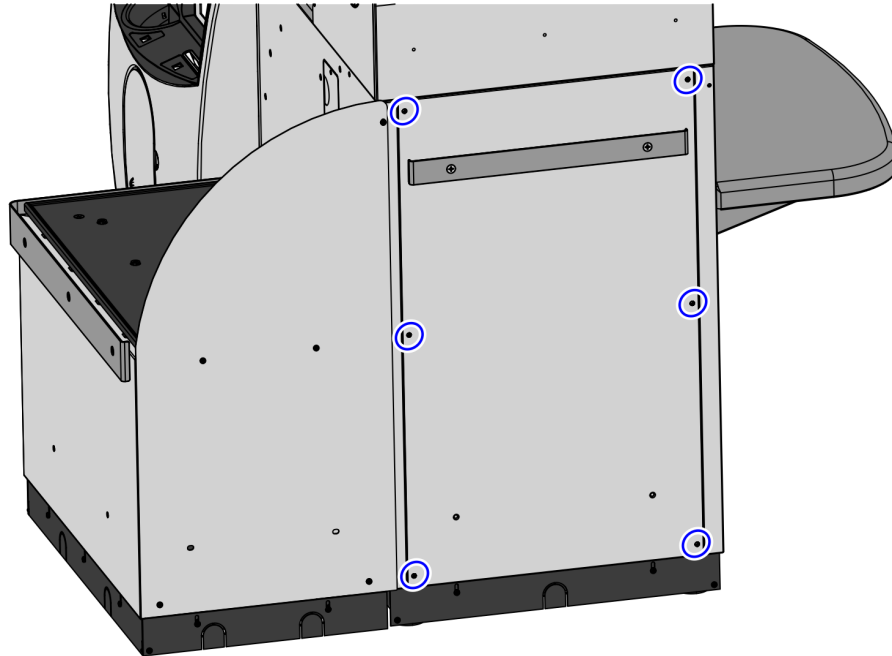

CCP-77340

5. Tilt the E-Box Bracket forward to easily access the cables.

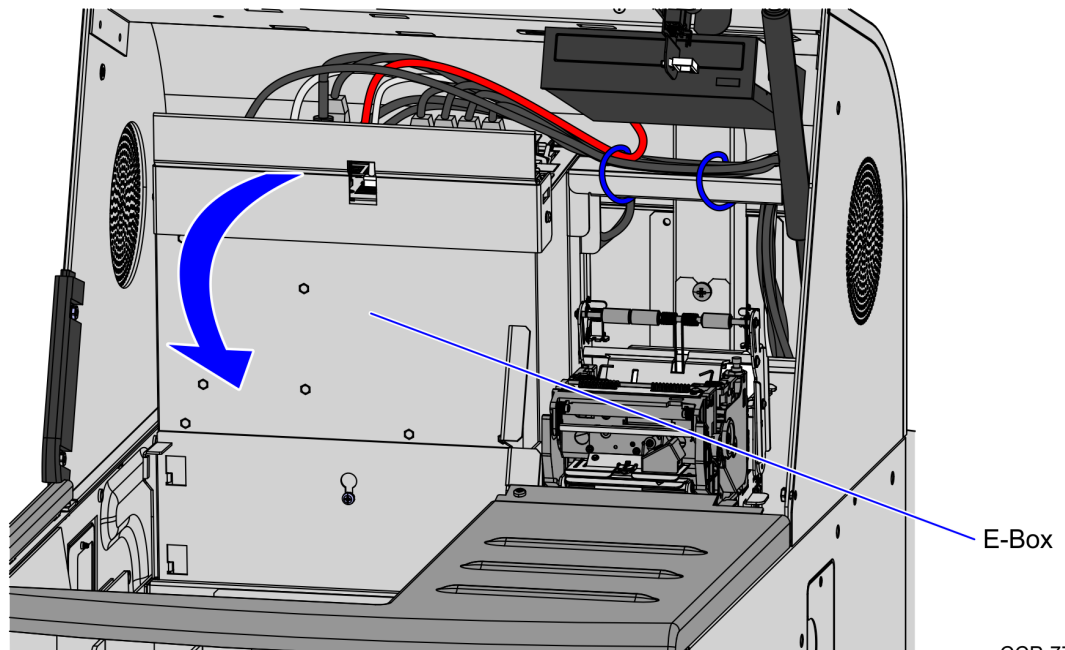

6. Unplug the pre-installed USB Power Cable from the Scale Controller in the new Bagwell and plug host connector to the USB M Port of the E-Box.

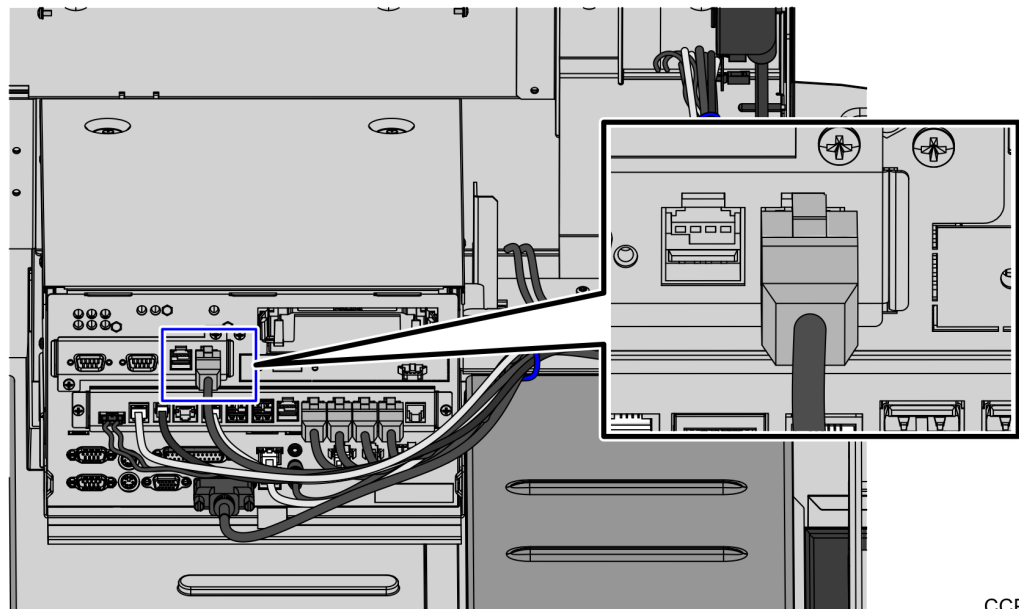

7. Tie the Scale Controller Cable to the main bundle by using six (6) cable ties.



Note: Secure the main cable to the E-Box with the first two (2) cable ties.

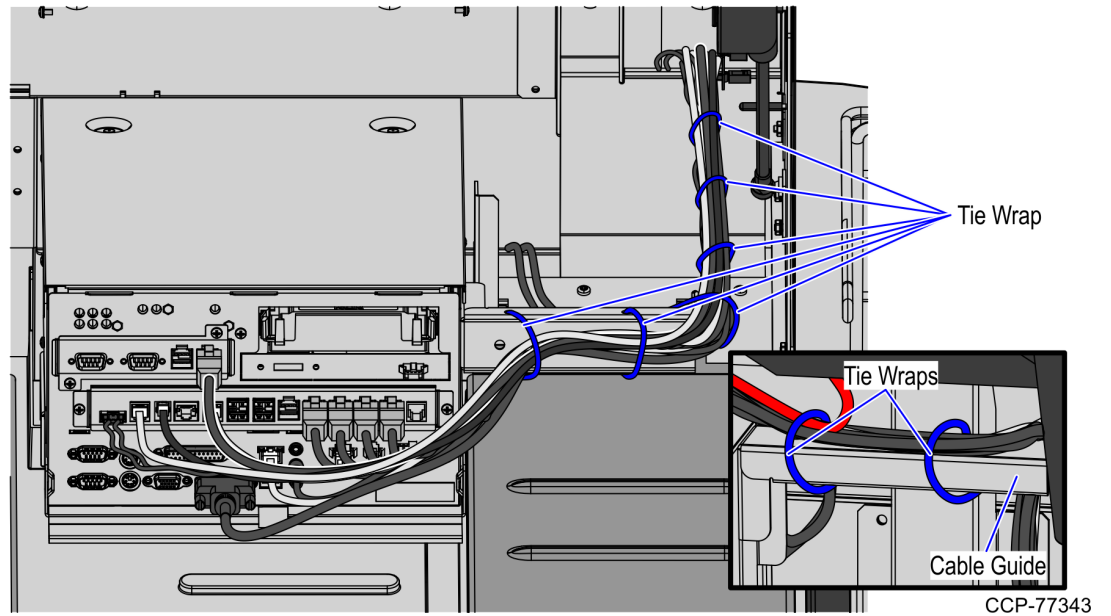

8. Continue routing the cable down the back of the Receipt Printer, as shown in the image below. Push all the cable slack to the rear of the Core.

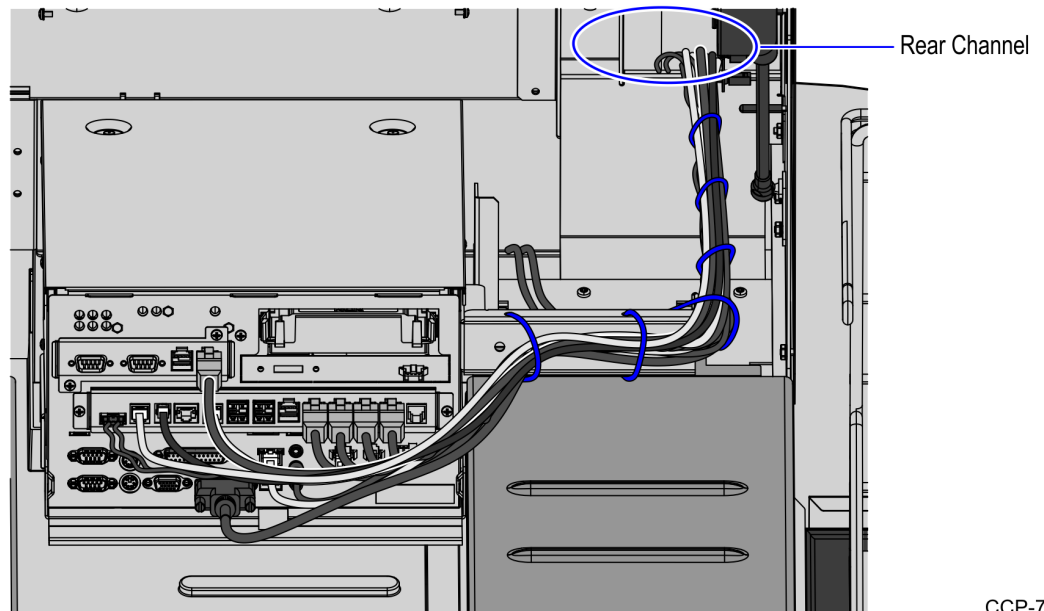

9. Ensure that the cable bundle is not in contact with the Tri-Light pole bracket, DVD Drive, and ventilation fan studs when the E-Box is tilted from **Up** to **Down** positions as shown in the image below.

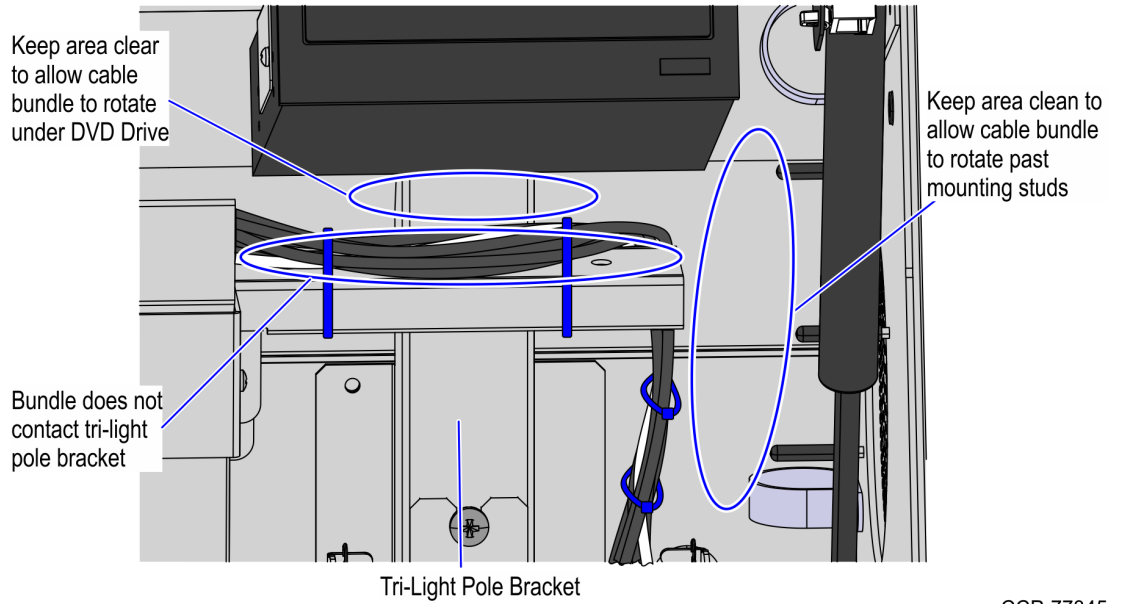

10. Rotate the E-Box back up. Help feed the cables down the back of the Receipt Printer to ensure that the cables are not tangled when the E-Box is rotated.

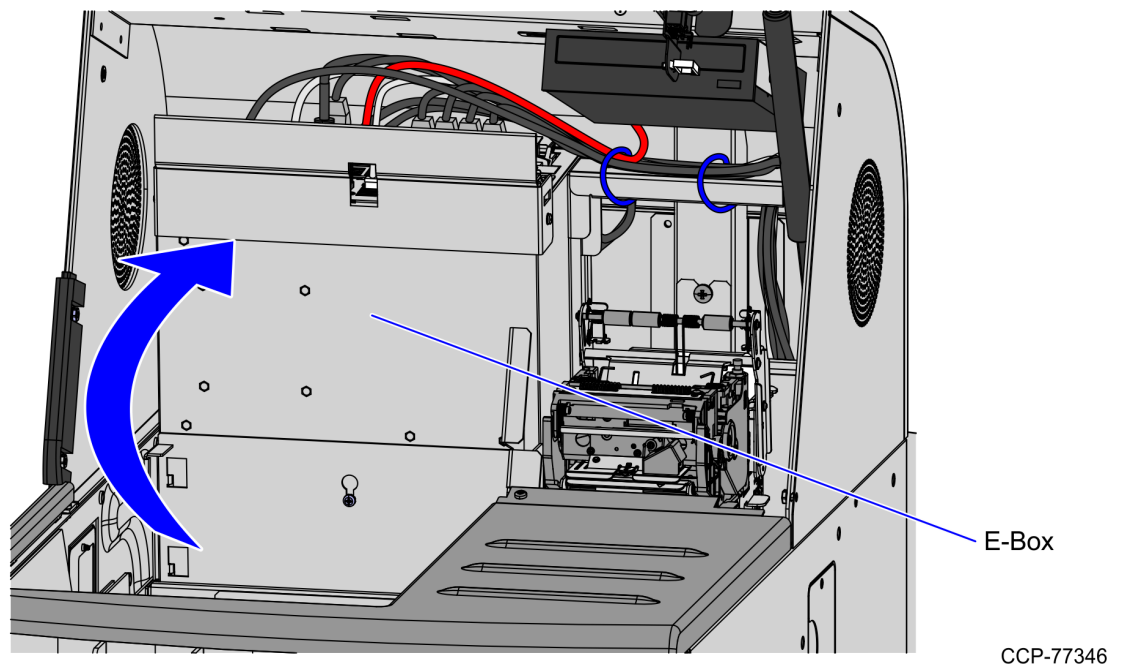

11. Install the Scanner/Scale. To install the Scanner/Scale, follow these steps:

- a. Grasp the Scanner/Scale by its handles and lower it into the checkstand cutout.

 **Caution:** Be careful not to damage any of the cables.

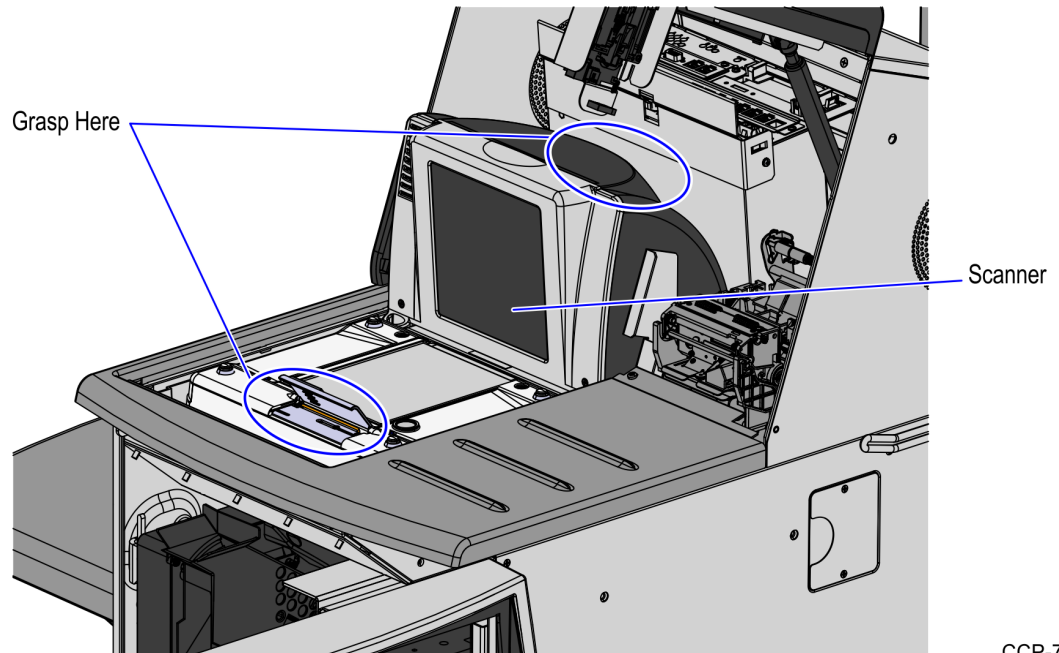

CCP-77347

- b. Place the back of Scanner/Scale on the two supports located on the E-Box mount.
- c. Lower the Scanner/Scale unto the scanner bucket area.
- d. Install the Scale Plate by placing it on top of the load cells.

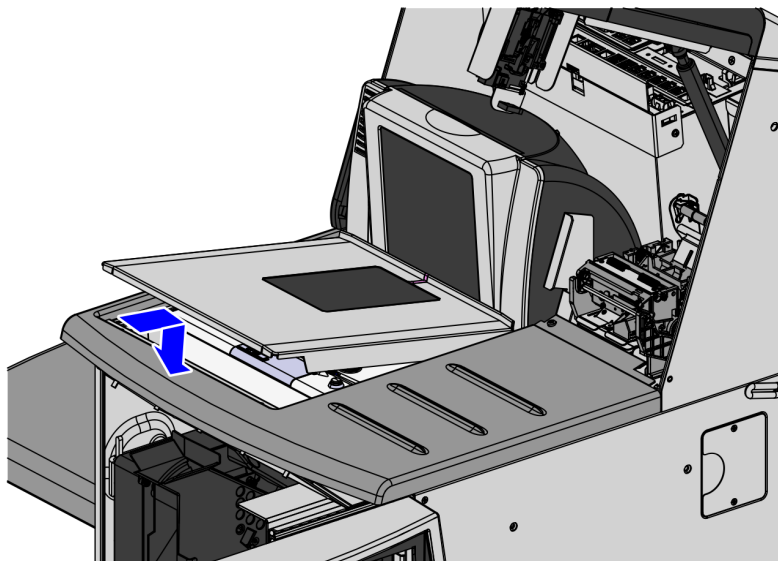

CCP-76753

12. Ensure the E-Box can rotate freely by adjusting the position of the cable as needed. USB Power Cable should be routed through the left hand lower Core access cutout into the new Bagwell.

13. Unplug the AC Power Out and AC Power In cables from the Power Strip. AC Power In Cable will be reused in the new Bagwell. AC Power Out Cable should be routed either through the left-hand or right-hand lower Core access cutout into the new Bagwell.



Note: The Power Strip remains on the rear Core wall but not reused.

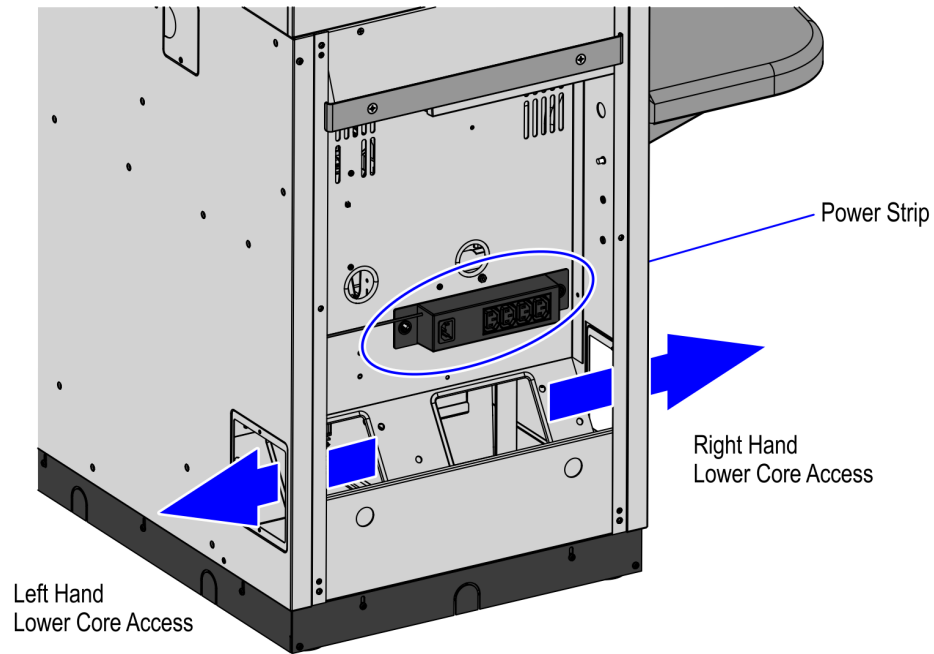

CCP-77348

14. Finish routing the cables into the Bagwell. For more information, refer to [Routing Cables](#) on page 38.

